

# MAC<sup>®</sup>

V A L V E S

## NEW Technology





	Page
Introduction	3
Section 1	Direct solenoid and solenoid pilot operated valves 9
Section 2	Remote air valves 197
Section 3	Bases according to ISO 5599 223
Section 4	Pressure regulators 243
Section 5	Intrinsically safe valves 299
Section 6	Options 307
Section 7	Supplemental technical information 321

MAC VALVES INC. has earned a reputation as an innovator in solenoid air valve technology as is evidenced by our numerous global patents.

MAC's designs focus on offering customers the best performing products available on the market. Some of the key features MAC's products offer are:

- reliability
- speed
- repeatability
- non lube service
- ease of maintenance
- compact packaging
- modularity
- specific application modifications
- low wattage
- broad electrical options

Many of these performance advantages are based on MAC's high shifting forces. MAC's patented oval shaped armature solenoid and 4-way pilot technologies are two new concepts which result in extremely high shifting forces in small packages.

The patented Latching Solenoid is another new offering to the MAC product line. The latching solenoid provides the function of a double solenoid operated valve utilizing only one solenoid.

## I. OVAL SHAPED ARMATURE SOLENOID – Maximized Shifting Forces

Compared with typical round armature solenoids, the oval shaped armature design results in much higher shifting forces due to the following:

- Increased coil windings (amp turns)
- Increased core iron volume

With more amp turns and core iron than conventional round armature designs, more shifting force is available to shift through contaminated air resulting in reliable shifting valves.

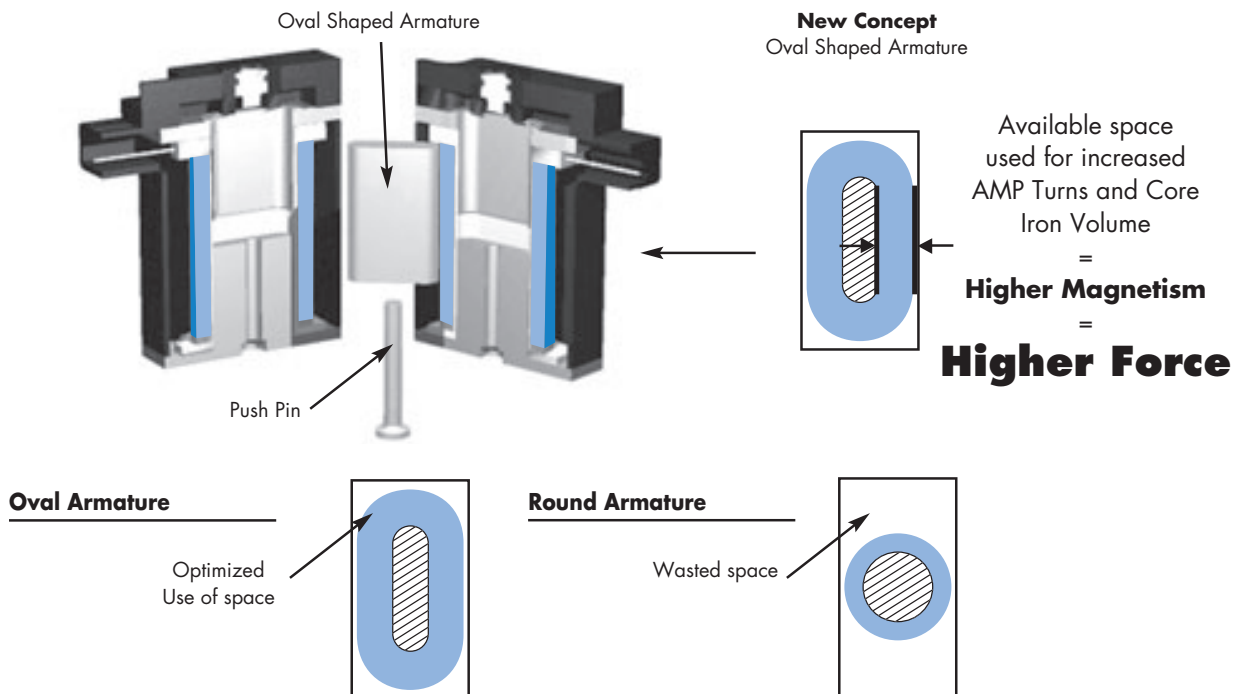

## DIRECT SOLENOID POPPET VALVE

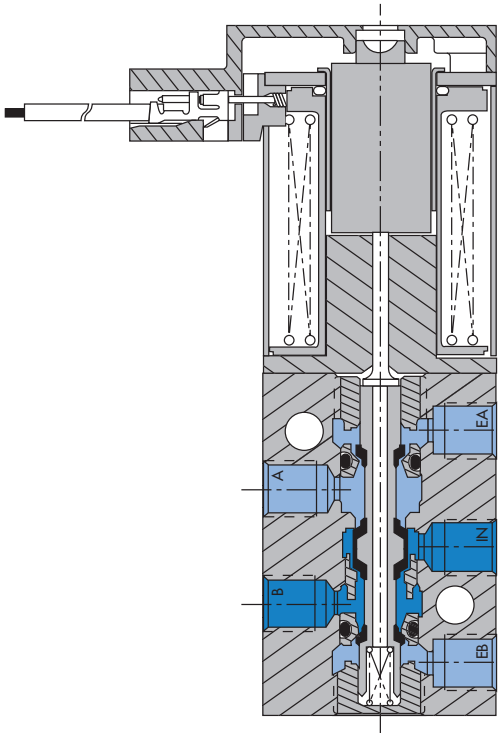

## SHORT STROKE

- Short Stroke = High solenoid force
- Short Stroke = High return spring force
- Short Stroke = Low current to shift solenoid

### DIRECT OPERATED 10 MM DESIGN WITH OVAL SHAPED ARMATURE

- Balanced poppet, with no seals of any kind in a bore - **no friction**
- New patented MAC solenoid® with "oval" shaped armature - provides **high shifting force** through more core iron and magnet wire
- Balanced poppet - **high shifting forces** - unaffected by fluctuations in air pressure
- Short stroke direct operated poppet valve (patented adjustable inlet seat controls stroke) - **high shifting force** - without small piston and no minimum operating pressure
- Large orifice "0.0024 in" minimum - **resists clogging**
- Strong return spring - **high shifting force** - even at low pressure
- Few parts - **simple design**
- Patented conical shaped exhaust seats act as cushions - **eliminates cutting - long life**
- Every valve calibrated for flow for a given coil wattage - **consistent flow**

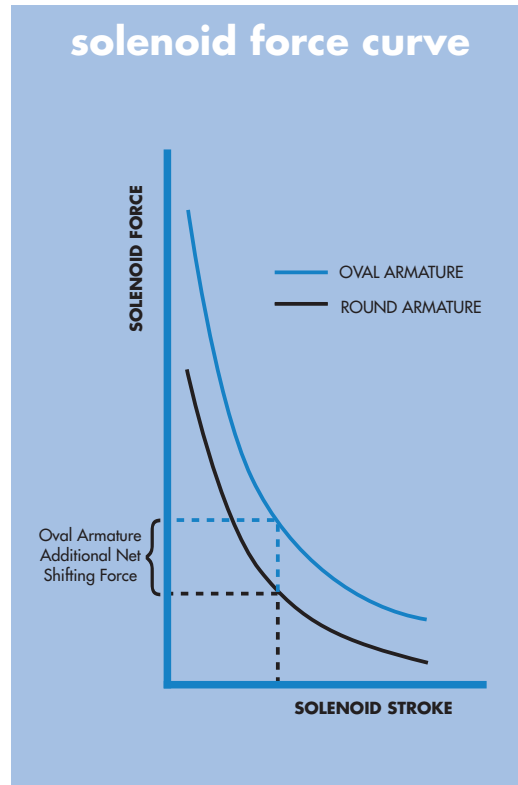

## II. MAC's 4-WAY PILOT SYSTEM – Maximized Shifting Forces

The balanced 4-way pilot valve provides maximum shifting forces in both directions by supplying air alternately to each end section of the spool, similar to double acting rodless cylinder. This system provides maximized shifting forces, equal forces at energization and de-energization, with no resistance to shifting at either end. The result is increased shifting reliability and faster, more consistent response times.

Small direct 4-way solenoid operated valve

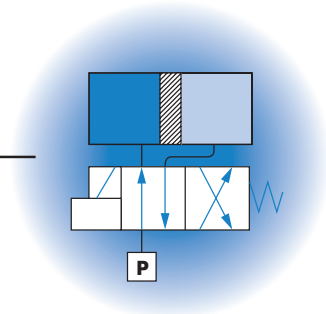
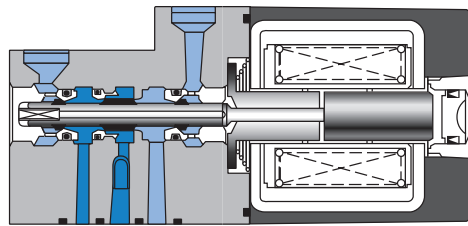

New concept : 4-way pilot

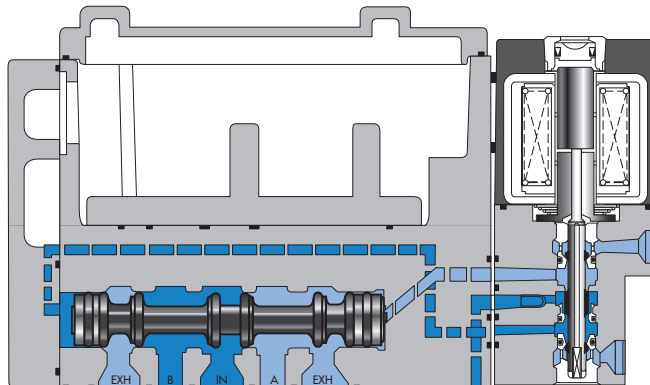
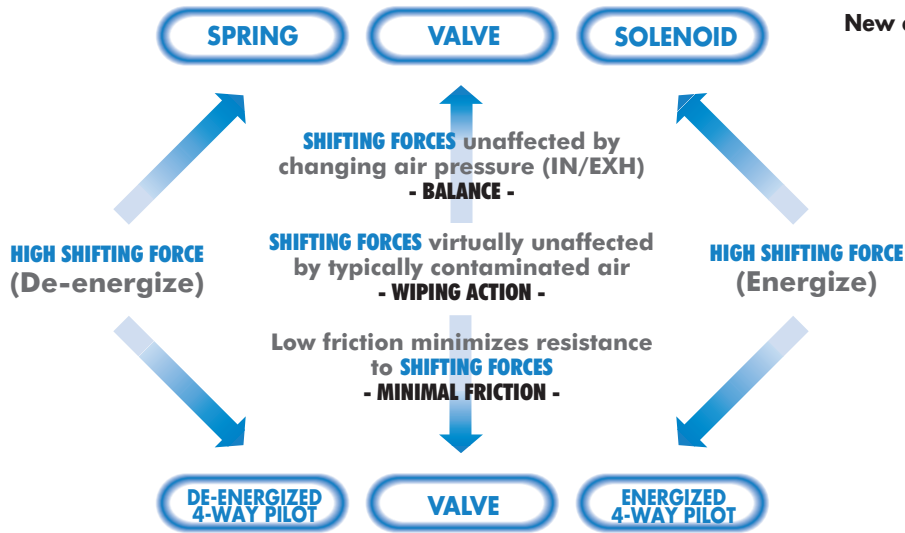

Solenoid pilot operated large valve

*Valves that don't stick*



ACT LOCAL

## MAC DISTRIBUTORS NETWORK

- 30 years experience
- Local support
- Globally linked network
- Special solutions
- Global customer partnership



○ **45 countries**

○ **3500 employees**

○ **200 service centers**

○ **\$ 50 million inventory**

○ **1000 factory certified application specialists**

KEEPING YOUR MACHINES RUNNING AROUND THE CLOCK AROUND THE WORLD

Let us show you via high performance demonstration kits and animated software,  
**HOW MAC'S PERFORMANCE ADVANTAGES HELP MAKE YOUR EQUIPMENT MORE RELIABLE - FASTER - MORE REPEATABLE.**



### TLD

Traveling Lab Demonstration measures critical valve performance characteristics - *Shifting forces, Response Time, Speed, Repeatability and Flow.*



### PLD

Proportional Lab Demonstration measures critical proportional regulation characteristics - *Response Time, Accuracy, Hysterisis, Repeatability and Flow.*



### Animation

Animated Software shows inner workings of various Air Valves Designs - *Powerful educational tool for learning about how air valves function.*

#### Other MAC VALVE literature:

DESCRIPTION	CATALOG NUMBER
CURRENT TECHNOLOGY	999CTCB
BUILDING BLOCKS BROCHURE	999ADVB
CIRCUIT BAR CATALOG	999CBCA
PROPORTIONAL VALVE CATALOG	999PPCB
CATALOG CD	999CCDB
SERIAL INTERFACE PRODUCTS	9999SI
MACONNECT SYSTEM	CONSULT FACTORY



999CTCB



999ADVB



999CBCA

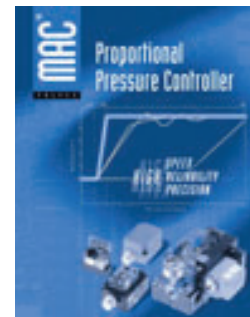

999PPCB

---



---



---



---



---

## Pneumatic functions

All valves inside the MAC product range allow for multiple pneumatic functions.  
Direct solenoid and solenoid pilot operated valves could be used as 2 ways, 3 ways (NO, NC) or 4 ways.  
When plugging one orifice to achieve a 2 way function (or 3 way), it will not affect the valve operation.

- Direct solenoid valves 3 ways : universal  
The following functions are available

- 3 ways NC
- 3 ways NO
- 2 ways NC
- 2 ways NO
- Selector
- Divertor

- Direct solenoid valves 4 ways :  
The following functions are available

- 4 ways
- 3 ways NC
- 3 ways NO
- 2 ways NC
- 2 ways NO
- Divertor

- Pilot operated valves 3 ways :  
The following functions are available

- 3 ways NC
- 3 ways NO
- 2 ways NC
- 2 ways NO
- Selector : the highest pressure is connected to the IN port; the lowest pressure is connected to the EXH port. (Use external pilot when the highest pressure is less than 25 PSI)
- Divertor (consult factory)

- Pilot operated valves 4 & 5 ways :  
The following functions are available

- 4 or 5 ways
- 3 ways NC
- 3 ways NO
- 2 ways NC
- 2 ways NO
- Selector (except 3 positions)
- Divertor (consult factory).

**EVERY VALVE FULLY TESTED PRIOR TO SHIPMENT**





## Section 1

## Direct solenoid and solenoid pilot operated valves



Function	Port size	Flow (Max) Cv	Individual mounting							
			Inline	Sub-base non "plug-in"	Sub-base "plug-in"	Sub-base/manifold base non "plug-in" with latching solenoid	Sub-base/manifold base "plug-in" with latching solenoid	Valve only - No base non "plug-in" Conform to ISO 5599/1	Valve only - No base "plug-in" Conform to ISO 5599/2	Valve only - No base non "plug-in" Conform to ISO 15407/1
<b>3/2</b>	<b>M3</b>	<b>0.082</b>	P. 15							
<b>3/2 - 2/2</b>	<b>M5 - #10-32</b>	<b>0.12</b>	P. 19							
<b>3/2</b>	<b>1/8"</b>	<b>0.3</b>	P. 23							
<b>3/2</b>	<b>1/8" - #10-32</b>	<b>0.3</b>								
<b>3/2</b>	<b>1/8" - 5/32</b> <small>O.D. pressed-in tube receptacle</small>	<b>0.3</b>								
<b>3/2</b>	<b>1/8"</b>	<b>0.4</b>		P. 33						
<b>3/2</b>	<b>#10-32 - 1/4"</b> <small>O.D. tube receptacle</small>	<b>0.4</b>			P. 35	P. 41	P. 43			
<b>3/2</b>	<b>1/8" - 1/4"</b>	<b>0.5</b>	P. 47	P. 49						
<b>3/2</b>	<b>1/8" - 1/4"</b> <small>O.D. tube receptacle</small>	<b>1.2</b>		P. 53	P. 55	P. 59	P. 61			
<b>3/2 - 2/2</b>	<b>1/8" - 1/4"</b>	<b>1.5</b>	P. 65							
<b>3/2 - 2/2</b>	<b>3/4" - 1"</b>	<b>20.0</b>	P. 69							
<b>3/2 - 2/2</b>	<b>1 1/2" - 2" - 2 1/2"</b>	<b>60.0</b>	P. 73							
<b>5/2</b>	<b>M5 - #10-32</b>	<b>0.1</b>	P. 77							
<b>4/2</b>	<b>1/8" - #10-32</b>	<b>0.3</b>	P. 81							
<b>4/2</b>	<b>1/8" - 5/32</b> <small>O.D. pressed-in tube receptacle</small>	<b>0.3</b>								
<b>5/2 - 5/3</b>	<b>#10-32 - 1/4"</b> <small>O.D. tube receptacle</small>	<b>0.4</b>		P. 95	P. 97					
<b>5/2</b>	<b>#10-32 - 1/4"</b> <small>O.D. tube receptacle</small>	<b>0.4</b>				P. 103	P. 105			
<b>5/2</b>	<b>1/8" - 1/4"</b>	<b>0.5</b>	P. 111	P. 113						
<b>5/2</b>	<b>1/8"</b>	<b>1.0</b>	P. 121							
<b>5/2 - 5/3</b>	<b>1/8"</b>	<b>1.1</b>		P. 125	P. 127					
<b>5/2</b>	<b>1/8"</b>	<b>1.1</b>				P. 133	P. 135			
<b>5/2 - 5/3</b>	<b>1/8" - 1/4"</b>	<b>1.0</b>	P. 141	P. 143						
<b>5/2 - 5/3</b>	<b>1/8" - 1/4" - 3/8"</b>	<b>1.2</b>		P. 147	P. 149					
<b>5/2 - 5/3</b>	<b>1/4" - 3/8"</b>	<b>1.2</b>								
<b>5/2 - 5/3</b>	<b>3/8" - 1/2"</b>	<b>3.8</b>	P. 159							
<b>5/2 - 5/3</b>	<b>1/4" - 3/8" - 1/2"</b>	<b>3.4</b>		P. 161	P. 163					
<b>5/2 - 5/3</b>	<b>1/4"</b>	<b>1.0</b>								P. 173
<b>5/2 - 5/3</b>	<b>1/8"</b>	<b>0.43</b>								P. 177
<b>5/2 - 5/3</b>	<b>1/4" - 3/8"</b>	<b>1.8</b>						P. 181	P. 165	
<b>5/2 - 5/3</b>	<b>3/8" - 1/2"</b>	<b>3.0</b>						P. 187	P. 189	
<b>5/2 - 5/3</b>	<b>1/2" - 3/4"</b>	<b>6.1</b>						P. 193	P. 195	

# solenoid pilot operated valves

## Manifold mounting

## Series

stacking	Manifold base non "plug-in"	Manifold base "plug-in"	Manifold base "plug-in" with pressure regulators	Manifold base "plug-in" with flow controls	Manifold base "plug-in" with PR & FC	Sub-base/ manifold base non "plug-in" with latching solenoid	Sub-base/ manifold base "plug-in" with latching solenoid	Valve only - No base non "plug-in" Conform to ISO 5599/1	Valve only - No base "plug-in" Conform to ISO 5599/2	Valve only - No base non "plug-in" Conform to ISO 15407/1	
											<b>33</b>
											<b>34</b>
											<b>36</b>
	P. 25		P. 27	P. 29							<b>32</b>
		P. 37	P. 39			P. 41	P. 43				<b>37</b>
		P. 57	P. 55			P. 59	P. 61				<b>38</b>
											<b>52</b>
											<b>67</b>
											<b>69</b>
											<b>44</b>
	P. 83		P. 85	P. 87	P. 89	P. 91					<b>46</b>
		P. 99	P. 101								<b>42</b>
						P. 103	P. 105				<b>47</b>
	P. 115		P. 117								<b>48P</b>
		P. 129	P. 131								<b>48</b>
						P. 133	P. 135				<b>400</b>
											<b>92</b>
		P. 151	P. 153								<b>93</b>
		P. 165	P. 167								<b>ISO 01</b>
										P.173	<b>ISO 02</b>
										P.177	<b>ISO 1</b>
								P. 181	P. 183		<b>ISO 2</b>
								P. 187	P. 189		<b>ISO 3</b>
								P. 193	P. 195		

# Direct solenoid and solenoid pilot operated valves

## 8 mm valve

Individual mounting

Series

Inline

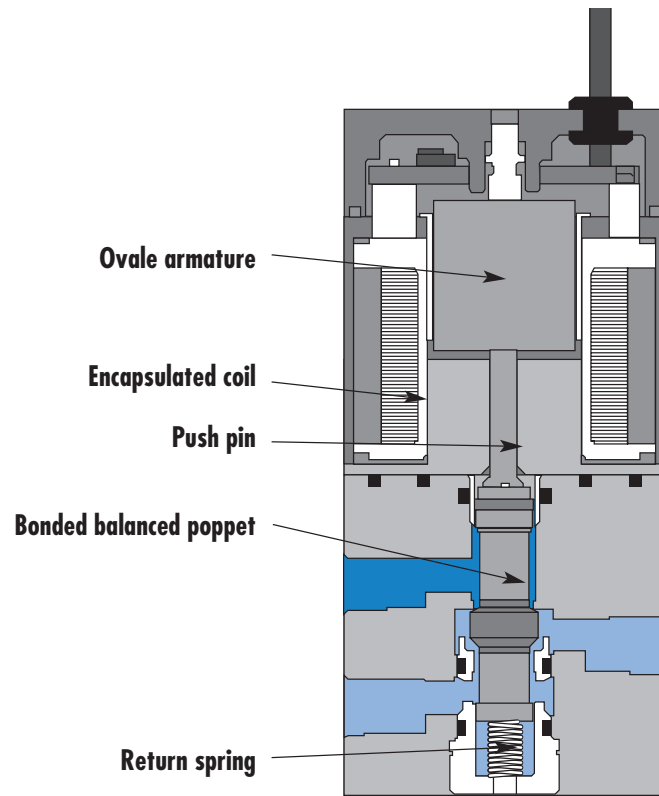

**33**

34

36

32

37

38

52

67

69

44

46

42

47

48P

48

400

92

93

ISO 01

ISO 02

ISO 1

ISO 2

ISO 3

### SERIES FEATURES

- Patented high force MACSOLENOID® for fastest possible response times.
- Bonded balanced poppet for high flow, precise repeatability, and consistent operation.
- Extremely high cycle rate capability.
- Use on lube or non-lube service.
- Low wattage DC solenoids-down to 0.5 W.
- 8 mm direct operated valve.
- Very fast response times.



# Direct solenoid and solenoid pilot operated valves

## 8 mm valve

Function	Port size	Flow (Max)	Individual mounting	Series
<b>3/2 NC</b>	<b>M3</b>	<b>0.082 C<sub>v</sub></b>	Inline	

### OPERATIONAL BENEFITS

1. 8mm valve direct solenoid operated.
2. Balanced poppet, immune to pressure variations.
3. Short stroke with high flow.
4. Patented solenoid develops high shifting forces.
5. Low wattage solenoids.
6. Powerful return spring.
7. Extremely fast response times.

Patents and patents pending

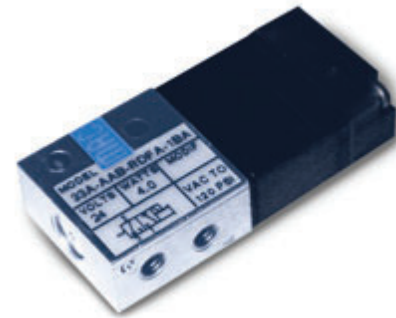

### HOW TO ORDER

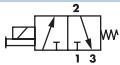
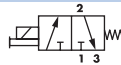
Port size	N.C. Only	N.C. Only **
<b>M3</b>	 33A-AAB-Rxxx-xxx	 33A-BAB-Rxxx-xxx

\*\* For use with solenoids above 4.0 W - MOD number required. (Consult factory)

### SOLENOID OPERATOR >

XX Voltage		X Lead wire length		X Manual operator		XX Electrical connection	
DA	24 VDC (0.5W)	0	No Lead wire*	0	No manual operator	BA	Flying leads
DB	24 VDC (1.0W)	A	18"	1	Non-locking recessed	BB	Flying leads w/LED
DC	24 VDC (1.8W)	B	24"	3	Non-locking extended	BC	Flying leads w/MOV
DF	24 VDC (4.0W)	C	36"			BD	Flying leads w/LED & MOV
DG	12 VDC (0.5W)	D	48"			RA	Mini JAC Solenoid plug-in
DH	12 VDC (1.0W)	E	72"			RB	Mini JAC Solenoid plug-in w/LED
DJ	12 VDC (1.8W)					RC	Mini JAC Solenoid plug-in w/MOV
DM	12 VDC (4.0W)					RD	Mini JAC Solenoid plug-in w/LED & MOV
						TA	JST Solenoid plug-in
						TB	JST Solenoid plug-in w/LED
						TC	JST Solenoid plug-in w/MOV
						TD	JST Solenoid plug-in w/LED & MOV

\* Other options available, see page 321.

Washdown capability is possible for the "B" and "R" type electrical connectors. Consult factory for ordering information.

33
34
36
32
37
38
52
67
69
44
46
42
47
48P
48
400
92
93
ISO 01
ISO 02
ISO 1
ISO 2
ISO 3

**TECHNICAL DATA**

<b>Fluid :</b>	Compressed air, vacuum, inert gases
<b>Pressure range :</b>	Vacuum to 120 PSI
<b>Lubrication :</b>	Not required, if used select a medium aniline point lubricant (between 180°F and 210°F)
<b>Filtration :</b>	40 $\mu$
<b>Temperature range :</b>	0°F to 120°F (-18°C to +50°C)
<b>Flow :</b>	4W: (Cv .082) - 3W: (Cv .062) - 2.5W: (Cv .062) - 1.8W: (Cv .055) - 1.0W: (Cv .030) - 0.5W: (Cv .020)
<b>Coil :</b>	Class A wire (#26 AWG x18), continuous duty
<b>Voltage range :</b>	-1.5% to +10% of nominal voltage
<b>Power :</b>	4.0W - 3.0W - 2.5W - 1.8W - 1.0W - 0.5W

**DIMENSIONS**

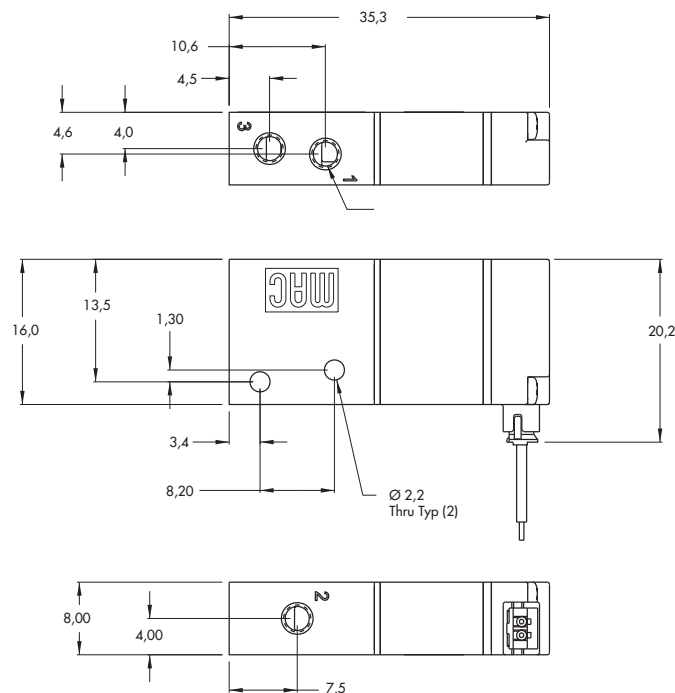

Individual mounting

Series

Inline	
--------	--

33  
**34**  
 36  
 32  
 37  
 38  
 52  
 67  
 69  
 44  
 46  
 42  
 47  
 48P  
 48  
 400  
 92  
 93  
 ISO 01  
 ISO 02  
 ISO 1  
 ISO 2  
 ISO 3

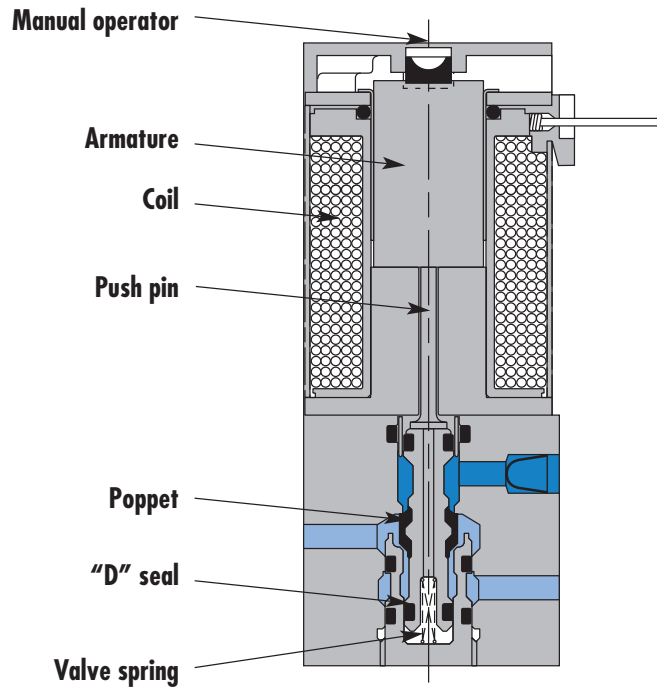

**SERIES FEATURES**

- High force MACSOLENOID®.
- Universal porting.
- # 10-32 or M5 ports.
- Rated for lubricated or non-lubricated service.
- 10 mm direct operated.



# Direct solenoid and solenoid pilot operated valves

Function	Port size	Flow (Max)	Individual mounting	Series
<b>3/2 NO-NC, 2/2 NO-NC</b>	<b>M5, # 10-32</b>	<b>0.12 C<sub>v</sub></b>	Inline	

### OPERATIONAL BENEFITS

1. 10 mm valve, direct solenoid operated.
2. Balanced poppet, immune to variations of pressure.
3. Short stroke with high flow.
4. Patented solenoid develops high shifting forces.
5. Powerful return spring.
6. Manual operator standard on all valves.



### HOW TO ORDER

Port size	Universal valve	NC only valve
<b>M5</b>	34C-ABA-G <b>xxx-xxx</b>	34C-ABB-G <b>xxx-xxx</b>
<b># 10-32</b>	34C-AAA-G <b>xxx-xxx</b>	34C-AAB-G <b>xxx-xxx</b>

### SOLENOID OPERATOR >

G **xxx-xxx\***

XX	Voltage	X	Wire length	X	Manual operator	XX	Electrical connection
AA	120 VAC (2.5W)	A	18"	1	Non-locking recessed	BA	Flying leads
DC	24 VDC (1.8W)	B	24"	3	Non-locking extended	BT	Flying leads with light
DD	24 VDC (2.5W)	C	36"			GA	MAC JAC Solenoid plug-in
DF	24 VDC (4.0W)					GB	MAC JAC Solenoid plug-in w/Diode
						GC	MAC JAC Solenoid plug-in w/MOV
						GD	MAC JAC Solenoid plug-in w/LED
						GE	MAC JAC Solenoid plug-in w/Diode & LED
						GF	MAC JAC Solenoid plug-in w/MOV & LED
						GG	MAC JAC Solenoid plug-in w/Rectifier
						GH	MAC JAC Solenoid plug-in w/Rectifier & LED
						KA	Plug-in wire assembly
						KC	Plug-in wire assembly with rectifier and light
						KT	Plug-in wire assembly with light

Note : AC voltage requires connector with rectifier.  
 \* Other options available, see page 311.

Washdown capability is possible for the "G" type electrical connectors.  
 Consult factory for ordering information.

- 33
- 34**
- 36
- 32
- 37
- 38
- 52
- 67
- 69
- 44
- 46
- 42
- 47
- 48P
- 48
- 400
- 92
- 93
- ISO 01
- ISO 02
- ISO 1
- ISO 2
- ISO 3



**TECHNICAL DATA**

<b>Fluid :</b>	Compressed air, vacuum, inert gases
<b>Pressure range :</b>	Vacuum to 120 PSI
<b>Lubrication :</b>	Not required, if used select a medium aniline point lubricant (between 180°F and 210°F)
<b>Filtration :</b>	40 μ
<b>Temperature range :</b>	0°F to 120°F (-18°C to +50°C)
<b>Flow :</b>	4 W : (0.12 C <sub>v</sub> ) – 2.5 W : (0.10 C <sub>v</sub> ) – 1.8 W : (0.06 C <sub>v</sub> )
<b>Coil :</b>	Class A wire (#22 AWG x 18), continuous duty
<b>Voltage range :</b>	-1.5% to +10% of nominal voltage
<b>Power :</b>	4 W – 2.5 W – 1.8 W
<b>Response times :</b> (with 4 W coil)	Energize : 3.4 ms De-energize : 1.5 ms

**DIMENSIONS**

Dimensions shown are metric (mm)

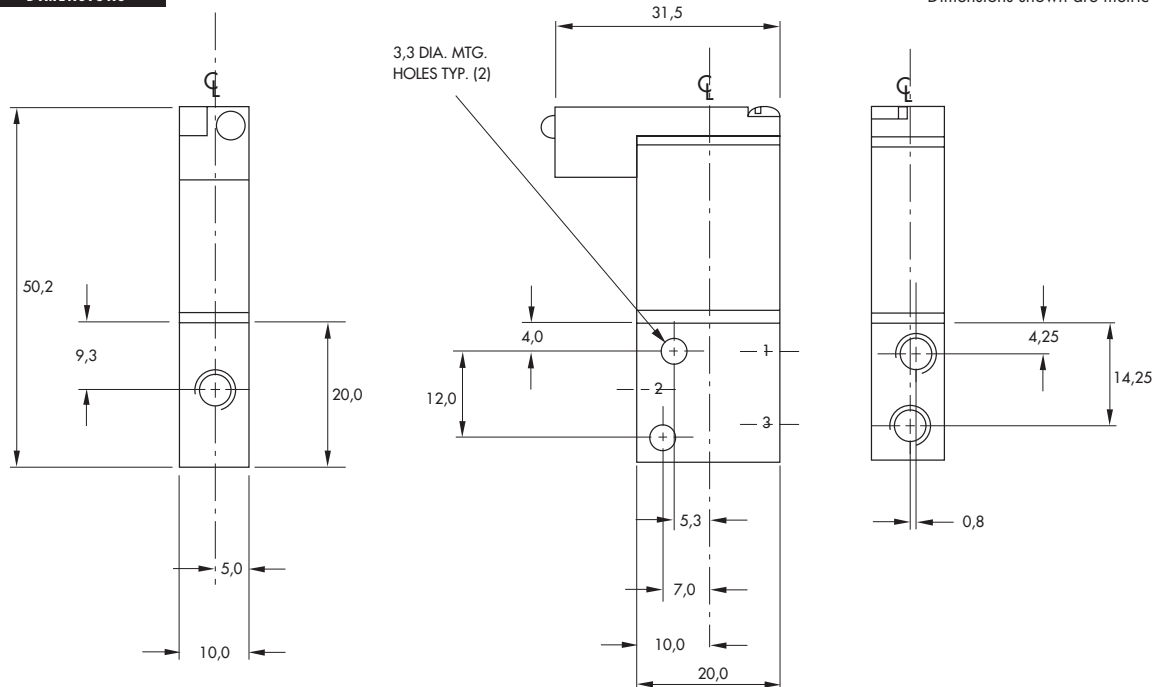

Individual mounting

Inline	
--------	--

Manifold mounting

Stacking	Manifold base "plug-in"	Manifold base "plug-in" with pressure regulators
----------	-------------------------	--

Series

33

34

36

32

37

38

52

67

69

44

46

42

47

48P

48

400

92

93

ISO 01

ISO 02

ISO 1

ISO 2

ISO 3

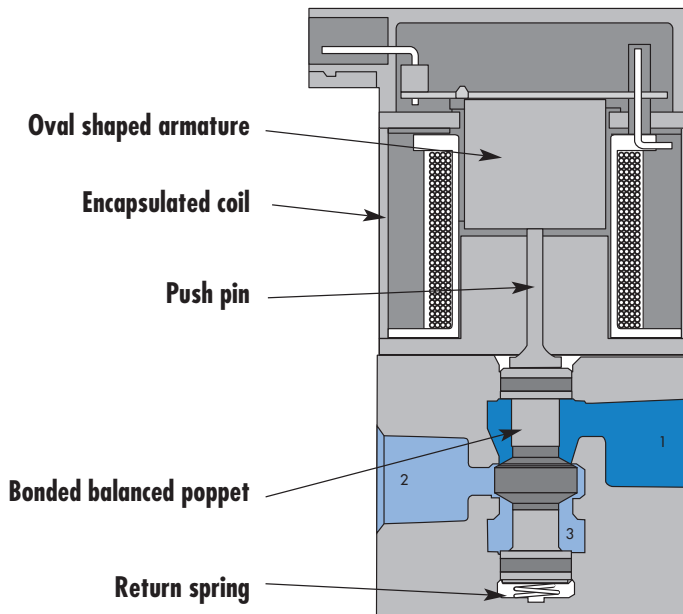

**SERIES FEATURES**

- Patented high force MACSOLENOID® for fastest possible response times.
- Bonded balanced poppet for high flow, precise repeatability, and consistent operation.
- Balanced poppet permits versatility in function — may be used as 3-way or 2-way normally open or normally closed and may be used for vacuum, diverter, or selector applications.
- Extremely high cycle rate capability.
- Use on lube or non-lube service.
- Manual overrides as standard.
- Various solenoid enclosures and plug-in connectors.
- Optional surge suppression available.
- Low wattage DC solenoids — down to 1.8 watts.
- Rectified AC voltage.



# Direct solenoid and solenoid pilot operated valves

Function	Port size	Flow (Max)	Individual mounting	Series
<b>3/2</b>	<b>1/8"</b>	<b>0.3 C<sub>v</sub></b>	Inline	

### OPERATIONAL BENEFITS

1. Balanced poppet, immune to variations of pressure.
2. Patented solenoid develops high shifting forces.
3. Short stroke with high flow.
4. Higher forces result in lower wattages for given flow.
5. Powerful return spring.



33  
34  
36

### HOW TO ORDER

Port size	Universal valve	NC only valve
<b>1/8" NPTF</b>	36A-AAA-J <b>XXX-XXX</b>	36A-AAB-J <b>XXX-XXX</b>

32  
37  
38  
52  
67  
69  
44  
46

### SOLENOID OPERATOR >

**J XXX-XXX\* (-G) Add "G" for ground**

XX	Voltage	X	Lead wire length	X	Manual operator	XX	Electrical connection
AA	120 VAC (5.4W)	A	18"	1	Non-locking recessed	BA	Flying leads
DA	24 VDC (5.4W)	B	24"	2	Locking recessed	GA	MAC JAC solenoid plug-in
DB	12 VDC (5.4W)	C	36"			GB	MAC JAC solenoid plug-in with diode
DC	24 VDC (2.4W)					GD	MAC JAC solenoid plug-in with light
DD	12 VDC (2.4W)					GG	MAC JAC solenoid plug-in with rectifier

42  
47  
48P  
48  
400  
92

\* Other options available, see page 317.  
 Note : - AC voltage requires connector with rectifier.  
 - With the MAC JAC, washdown capability is possible. Consult factory for washdown modification number.

93  
ISO 01  
ISO 02  
ISO 1  
ISO 2  
ISO 3

**TECHNICAL DATA**

<b>Fluid :</b>	Compressed air, vacuum, inert gases
<b>Pressure range :</b>	Vacuum to 120 PSI
<b>Lubrication :</b>	Not required, if used select a medium aniline point lubricant (between 180°F and 210°F)
<b>Filtration :</b>	40 μ
<b>Temperature range :</b>	0°F to 120°F (-18°C to +50°C)
<b>Flow :</b>	1.8 Watt: (0.15 C <sub>v</sub> ), 2.4 Watt: (0.15 C <sub>v</sub> ), 5.4 Watt: (0.30 C <sub>v</sub> )
<b>Coil :</b>	Class A wire (#22 AWG x 12), continuous duty
<b>Voltage range :</b>	-1.5% to +10% of nominal voltage
<b>Protection :</b>	Consult factory
<b>Power :</b>	5.4 W – 2.4 W – 1.8 W

Option : • BSPP threads

**DIMENSIONS**

Dimensions shown are metric (mm)

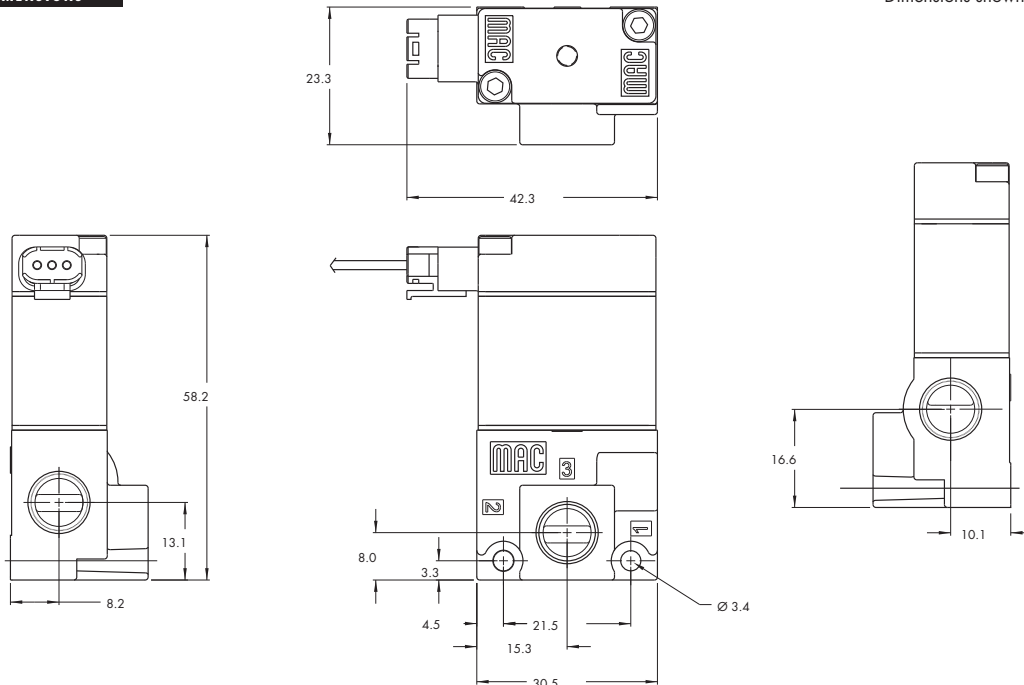



# Direct solenoid and solenoid pilot operated valves

Function	Port size	Flow (Max)	Individual mounting	Series
<b>3/2</b>	<b>1/8" - # 10-32</b>	<b>0.3 C<sub>v</sub></b>	Stacking	

### OPERATIONAL BENEFITS

1. Balanced poppet, immune to variations of pressure.
2. Patented solenoid develops high shifting forces.
3. Short stroke with high flow.
4. Higher forces result in lower wattages for given flow.
5. Powerful return spring.



33  
34  
36

32  
37  
38  
52  
67

### HOW TO ORDER

Port size	NC only stacking	NC stacking Universal poppet	NO stacking Universal poppet
<b>1/8" NPTF</b>	36A-SAB-J xxx-xxx	36A-SAC-J xxx-xxx	36A-SAD-J xxx-xxx
<b># 10-32</b>	36A-SBB-J xxx-xxx	36A-SBC-J xxx-xxx	36A-SBD-J xxx-xxx

69  
44  
46

42  
47  
48P

### SOLENOID OPERATOR >

**J XXX-XXX\* (-G) Add "G" for ground**

XX Voltage	X Lead wire length	X Manual operator	XX Electrical connection
<b>AA</b> 120 VAC (5.4W)	<b>A</b> 18"	<b>1</b> Non-locking recessed	<b>BA</b> Flying leads
<b>DA</b> 24 VDC (5.4W)	<b>B</b> 24"	<b>2</b> Locking recessed	<b>GA</b> MAC JAC solenoid plug-in
<b>DB</b> 12 VDC (5.4W)	<b>C</b> 36"		<b>GB</b> MAC JAC solenoid plug-in with diode
<b>DC</b> 24 VDC (2.4W)			<b>GD</b> MAC JAC solenoid plug-in with light
<b>DD</b> 12 VDC (2.4W)			<b>GG</b> MAC JAC solenoid plug-in with rectifier

48  
400

92  
93

\* Other options available, see page 317.  
 Note : - AC voltage requires connector with rectifier.  
 - With the MAC JAC, washdown capability is possible. Consult factory for washdown modification number.  
 End plate kit required (port size 1/4") : M-36001-01.

### BODY TYPE OPTIONS

36A-SAB-Jxxx-xxx	<b>S</b> Stacking body
	<b>T</b> Stacking body with bottom inlet

ISO 01  
ISO 02  
ISO 1  
ISO 2  
ISO 3

**TECHNICAL DATA**

<b>Fluid :</b>	Compressed air, vacuum, inert gases
<b>Pressure range :</b>	Vacuum to 120 PSI
<b>Lubrication :</b>	Not required, if used select a medium aniline point lubricant (between 180°F and 210°F)
<b>Filtration :</b>	40 μ
<b>Temperature range :</b>	0°F to 120°F (-18°C to +50°C)
<b>Flow :</b>	1.8 Watt: (0.15 C <sub>v</sub> ), 2.4 Watt: (0.15 C <sub>v</sub> ), 5.4 Watt: (0.30 C <sub>v</sub> )
<b>Coil :</b>	Class A wire (#22 AWG x 12), continuous duty
<b>Voltage range :</b>	-1.5% to +10% of nominal voltage
<b>Protection :</b>	Consult factory
<b>Power :</b>	5.4 W – 2.4 W – 1.8 W

- Option : • BSPP threads
- Spare parts : • Inlet & exhaust isolator plate : N-36001 • Inlet isolator : N-36002  
 • Exhaust isolator : N-36003 • Tie rod (x2) : 79411

**DIMENSIONS**

Dimensions shown are metric (mm)

Note: Isolator adds 2.5 mm to length of stack.

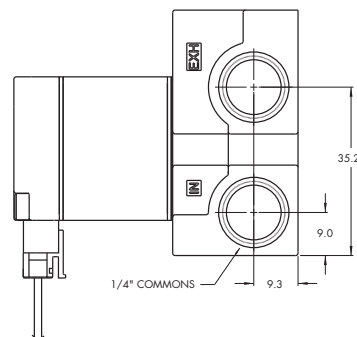
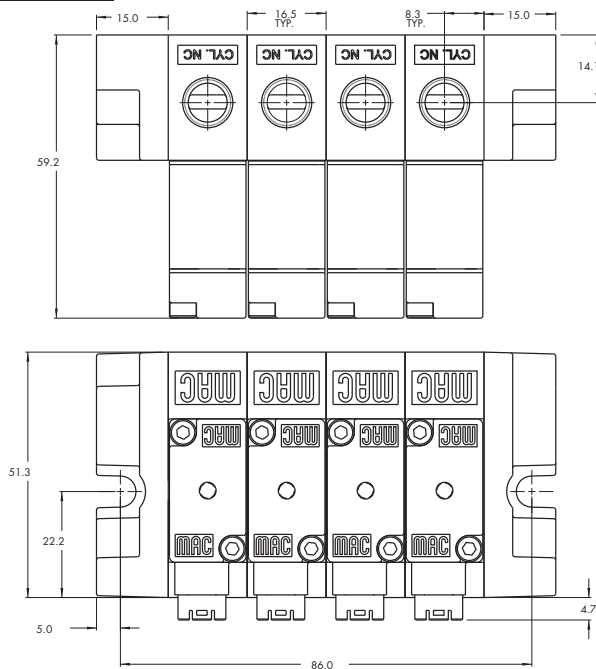

Function	Port size	Flow (Max)	Individual mounting	Series
<b>3/2</b>	<b>1/8" - 5/32 Pressed-in tube receptacle</b>	<b>0.3 C<sub>v</sub></b>	Manifold base "plug-in"	

**OPERATIONAL BENEFITS**

1. Balanced poppet, immune to variations of pressure.
2. Patented solenoid develops high shifting forces.
3. Short stroke with high flow.
4. Higher forces result in lower wattages for given flow.
5. Powerful return spring.



33

34

36

32

37

38

52

67

69

44

46

42

47

48

48P

48

400

92

93

ISO 01



ISO 02

ISO 1

ISO 2

ISO 3

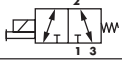
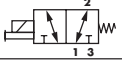
**HOW TO ORDER**

Port size	Universal Valve Normally Closed	Universal Valve Normally Open	Normally Closed Only
			
<b>Valve less base</b>	36A-J00-00-J <b>XX</b> P- <b>XXX</b>	36A-K00-00-J <b>XX</b> P- <b>XXX</b>	36A-L00-00-J <b>XX</b> P- <b>XXX</b>
<b>1/8" NPTF</b>	36A-JSA-AE-J <b>XX</b> P- <b>XXX</b>	36A-KSA-AF-J <b>XX</b> P- <b>XXX</b>	36A-LSA-AE-J <b>XX</b> P- <b>XXX</b>
<b>5/32 tube receptacle</b>	36A-JSF-AE-J <b>XX</b> P- <b>XXX</b>	36A-KSF-AF-J <b>XX</b> P- <b>XXX</b>	36A-LSF-AE-J <b>XX</b> P- <b>XXX</b>

SOLENOID OPERATOR >

J **XX** P-**XXX**\* (-G) Add "G" for ground

<b>XX</b> Voltage	<b>X</b> Manual operator	<b>XX</b> Electrical connection
<b>AA</b> 120 VAC (5.4W)	<b>1</b> Non-locking recessed	<b>FA</b> Base plug-in
<b>DA</b> 24 VDC (5.4W)	<b>2</b> Locking recessed	<b>FB</b> Base plug-in with diode
<b>DB</b> 12 VDC (5.4W)		<b>FG</b> Base plug-in with rectifier
<b>DC</b> 24 VDC (2.4W)		
<b>DD</b> 12 VDC (2.4W)		

\* Other options available, see page 317.

Note : AC voltage requires connector with rectifier.

Example : Manifold base only : 36A-0SA-AE (Normally closed manifold base).

End plate kit required (port size 1/4") : M-46003-01.

**TECHNICAL DATA**

<b>Fluid :</b>	Compressed air, vacuum, inert gases
<b>Pressure range :</b>	Vacuum to 120 PSI
<b>Lubrication :</b>	Not required, if used select a medium aniline point lubricant (between 180°F and 210°F)
<b>Filtration :</b>	40 μ
<b>Temperature range :</b>	0°F to 120°F (-18°C to +50°C)
<b>Flow :</b>	1.8W : (0.20 C <sub>v</sub> ) – 2.4W : (0.20 C <sub>v</sub> ) – 5.4W : (0.30 C <sub>v</sub> )
<b>Coil :</b>	Class A continuous duty, #22 AWG x 12 base leads
<b>Voltage range :</b>	-1.5% to +10% of nominal voltage
<b>Protection :</b>	Consult Factory
<b>Power :</b>	5.4 W – 2.4 W – 1.8 W

- Option :
  - BSPP threads
- Spare parts :
  - Inlet isolator : 28501 • Exhaust isolator : 28502 • Valve cover plate : M-46002
  - Tie rod (x2) : 79443

**DIMENSIONS**

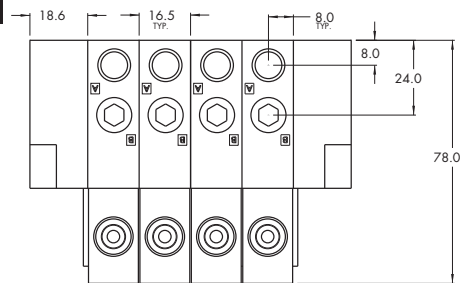

Dimensions shown are metric (mm)

Note: For Normally closed manifold the "A" port is plugged.  
For Normally open manifold the "B" port is plugged.

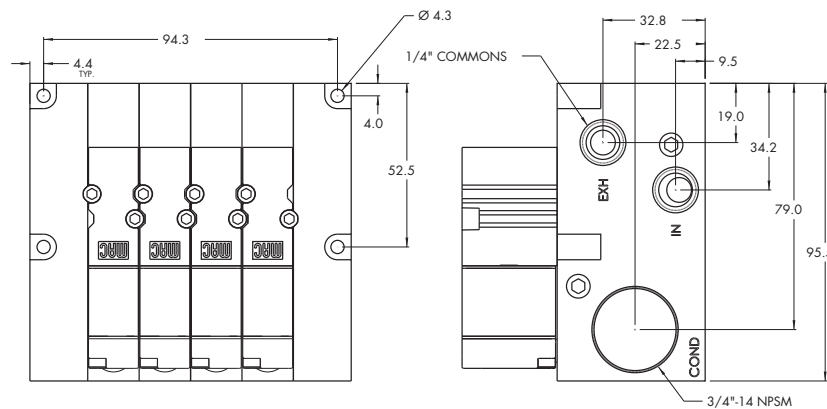



Function	Port size	Flow (Max)	Individual mounting	Series
<b>3/2</b>	<b>1/8" - 5/32 Pressed-in tube receptacle</b>	<b>0.3 C<sub>v</sub></b>	Manifold base "plug-in" with pressure regulators	

### OPERATIONAL BENEFITS



1. Balanced poppet, immune to variations of pressure.
2. Patented solenoid develops high shifting forces.
3. Short stroke with high flow.
4. Higher forces result in lower wattages for given flow.
5. Powerful return spring.



33  
34  
36

32  
37  
38  
52  
67

### HOW TO ORDER

Port size	Universal Valve Normally Closed	Universal Valve Normally Open	Normally Closed Only
			
<b>Valve less base</b>	36A-J00-00-J xxP-xxx	36A-K00-00-J xxP-xxx	36A-L00-00-J xxP-xxx
<b>1/8" NPTF</b>	36A-JSA-AG-J xxP-xxx	36A-KSA-AH-J xxP-xxx	36A-LSA-AG-J xxP-xxx
<b>5/32 tube receptacle</b>	36A-JSF-AG-J xxP-xxx	36A-KSF-AH-J xxP-xxx	36A-LSF-AG-J xxP-xxx

69  
44  
46

### SOLENOID OPERATOR >

**J XX P-xxx** (-G) Add "G" for ground

XX Voltage	X Manual operator	XX Electrical connection
<b>AA</b> 120 VAC (5.4W)	<b>1</b> Non-locking recessed	<b>FA</b> Base plug-in
<b>DA</b> 24 VDC (5.4W)	<b>2</b> Locking recessed	<b>FB</b> Base plug-in with diode
<b>DB</b> 12 VDC (5.4W)		<b>FG</b> Base plug-in with rectifier
<b>DC</b> 24 VDC (2.4W)		
<b>DD</b> 12 VDC (2.4W)		

47  
48P  
48

\* Other options available, see page 317.  
Note : AC voltage requires connector with rectifier.

### OPTIONS

36A-JSA-AG-Jxx P-xxx	<ul style="list-style-type: none"> <li><b>G</b> NC manifold &amp; regulator with slotted stem adjustment</li> <li><b>S</b> NC manifold &amp; regulator with locking slotted stem adjustment</li> <li><b>J</b> NC manifold &amp; regulator with knob adjustment</li> </ul>	36A-KSA-AH-Jxx P-xxx	<ul style="list-style-type: none"> <li><b>H</b> NO manifold &amp; regulator with slotted stem adjustment</li> <li><b>T</b> NO manifold &amp; regulator with locking slotted stem adjustment</li> <li><b>K</b> NO manifold &amp; regulator with knob adjustment</li> </ul>
----------------------	---	----------------------	---

Note : All manifold bases are only available with a bottom cylinder port.

Example : Manifold base only : 36A-0SA-AJ (Normally closed manifold base & regulator with knob).

End plate kit required (port size 1/4") : M-46003-01.

400  
92  
93

ISO 01  
ISO 02  
ISO 1  
ISO 2  
ISO 3

**TECHNICAL DATA**

<b>Fluid :</b>	Compressed air, vacuum, inert gases
<b>Pressure range :</b>	Vacuum to 120 PSI
<b>Lubrication :</b>	Not required, if used select a medium aniline point lubricant (between 180°F and 210°F)
<b>Filtration :</b>	40 μ
<b>Temperature range :</b>	0°F to 120°F (-18°C to +50°C)
<b>Flow :</b>	1.8W : (0.20 C <sub>v</sub> ) – 2.4W : (0.20 C <sub>v</sub> ) – 5.4W : (0.30 C <sub>v</sub> )
<b>Coil :</b>	Class A continuous duty, #22 AWG x 12 base leads
<b>Voltage range :</b>	-1.5% to +10% of nominal voltage
<b>Protection :</b>	Consult Factory
<b>Power :</b>	5.4 W – 2.4 W – 1.8 W

- Option : • BSPP threads
- Spare parts : • Inlet isolator : 28501 • Exhaust isolator : 28502 • Valve cover plate : M-46002  
• Tie rod (x2) : 79443

**DIMENSIONS**

Dimensions shown are metric (mm)

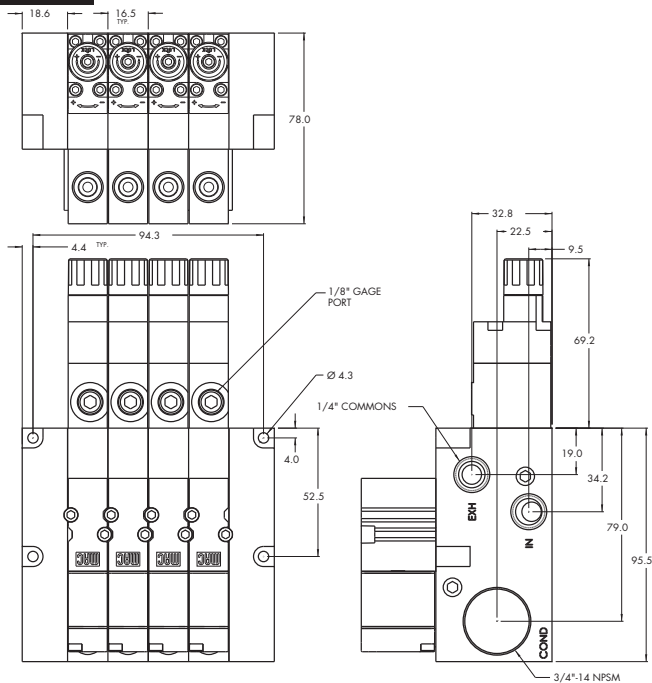

Note: For Normally closed manifold the "A" port is plugged.  
For Normally open manifold the "B" port is plugged.

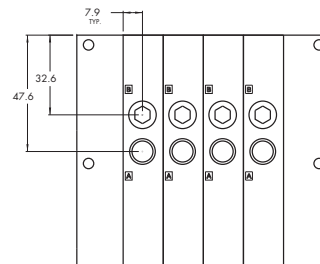

Individual mounting

Sub-base non "plug-in"	Sub-base "plug-in"	Sub-base/manifold base non "plug-in" with latching solenoid	Sub-base/manifold base "plug-in" with latching solenoid
------------------------	--------------------	---	---

Series

Manifold mounting

Manifold base non "plug-in"	Manifold base "plug-in"	Sub-base/manifold base non "plug-in" with latching solenoid	Sub-base/manifold base "plug-in" with latching solenoid
-----------------------------	-------------------------	---	---

33  
34  
36

**32**

37

38

52

67

69

44

46

42

47

48P

48

400

92

93

ISO 01

ISO 02

ISO 1

ISO 2

ISO 3

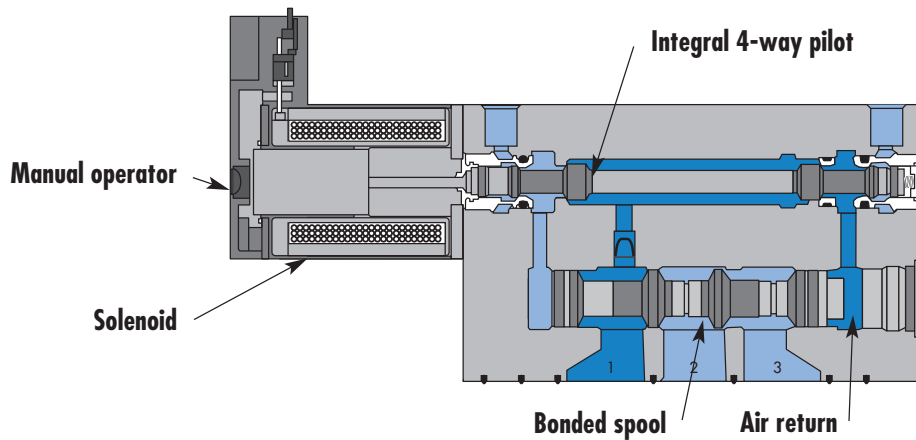

**SERIES FEATURES**

- High force MACSOLENOID®.
- Integral 4-way pilot design.
- Internal or external pilot.
- Normally open or normally closed function.
- Universal function (external pilot).
- Rectified AC voltage.
- Latching solenoid technology.



# Direct solenoid and solenoid pilot operated valves

Function	Port size	Flow (Max)	Individual mounting	Series
<b>3/2 NO-NC</b>	<b>1/8"</b>	<b>0.4 C<sub>v</sub></b>	Sub-base non "plug-in"	

### OPERATIONAL BENEFITS

1. 3-way valve with 4-way integral pilot.
2. 10 mm valve (stacks on 10.5 mm centers).
3. High flow (up to 0.4 C<sub>v</sub>).
4. Fast, repeatable response times.
5. Maximum shifting forces in both directions.



33  
34  
36  
**32**

### HOW TO ORDER

Port size	Pilot air	NO valve	NC valve	Universal valve
<b>Valve less base</b>	Internal	32B-BMA-000-Gxxx-xxx	32B-AMA-000-Gxxx-xxx	
	External	32B-BMB-000-Gxxx-xxx	32B-AMB-000-Gxxx-xxx	32B-GMB-000-Gxxx-xxx
<b>1/8" NPTF</b>	Internal	32B-BMA-CAL-Gxxx-xxx	32B-AMA-CAL-Gxxx-xxx	
	External	32B-BMB-CAM-Gxxx-xxx	32B-AMB-CAM-Gxxx-xxx	32B-GMB-CAM-Gxxx-xxx

Note : Above codes are for side port.

### STANDARD SOLENOID OPERATOR >

G XXX-XXX*		G XXX-XXX*		G XXX-XXX*	
XX Voltage	X Wire length	X Manual operator	XX Electrical connection		
AA 120 VAC (2.5W)	A 18"	1 Non-locking recessed	BA Flying leads		
DA 24 VDC (1.0W)	B 24"	2 Locking recessed	BT Flying leads with light		
DC 24 VDC (1.8W)	C 36"		GA MAC JAC Solenoid plug-in		
DD 24 VDC (2.5W)			GB MAC JAC Solenoid plug-in w/Diode		
DF 24 VDC (4.0W)			GC MAC JAC Solenoid plug-in w/MOV		
			GD MAC JAC Solenoid plug-in w/LED		
			GE MAC JAC Solenoid plug-in w/Diode & LED		
			GF MAC JAC Solenoid plug-in w/MOV & LED		
			GG MAC JAC Solenoid plug-in w/Rectifier		
			GH MAC JAC Solenoid plug-in w/Rectifier & LED		
			KA Plug-in wire assy.		
			KT Plug-in wire assy. with light		
			KD Plug-in wire assy. with rectifier & light & ground		

Note : AC voltage requires connector with rectifier.

\* Other options available, see page 311.

Latching solenoid also available, see page 41.

With MAC JAC electrical connector washdown capability is possible.

Consult factory for modification number.

### OPTIONS

Pilot/Base Configuration :

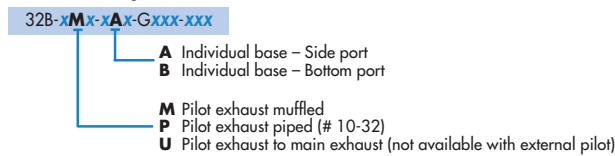

46

42

47

48P

48

400

92

93

ISO 01

ISO 02

ISO 1

ISO 2

ISO 3

**TECHNICAL DATA**

<b>Fluid :</b>	Compressed air, vacuum, inert gases
<b>Pressure range :</b>	Internal Pilot : 20 to 120 PSI External Pilot : Vacuum to 120 PSI
<b>Pilot pressure :</b>	20 to 120 PSI
<b>Lubrication :</b>	Not required, if used select a medium aniline point lubricant (between 180°F and 210°F)
<b>Filtration :</b>	40 μ
<b>Temperature range :</b>	0°F to 120°F (-18°C to +50°C)
<b>Flow :</b>	1/8" : (0.40 C <sub>v</sub> )
<b>Coil :</b>	Class A wire (#22 AWG x 18), continuous duty
<b>Voltage range :</b>	-15% to +10% of nominal voltage
<b>Power :</b>	1.0 to 4.0 W
<b>Response times : (with 4 W coil)</b>	Energize : 5 ms De-energize : 5 ms

Options : • BSPP threads

**DIMENSIONS**

Dimensions shown are metric (mm)

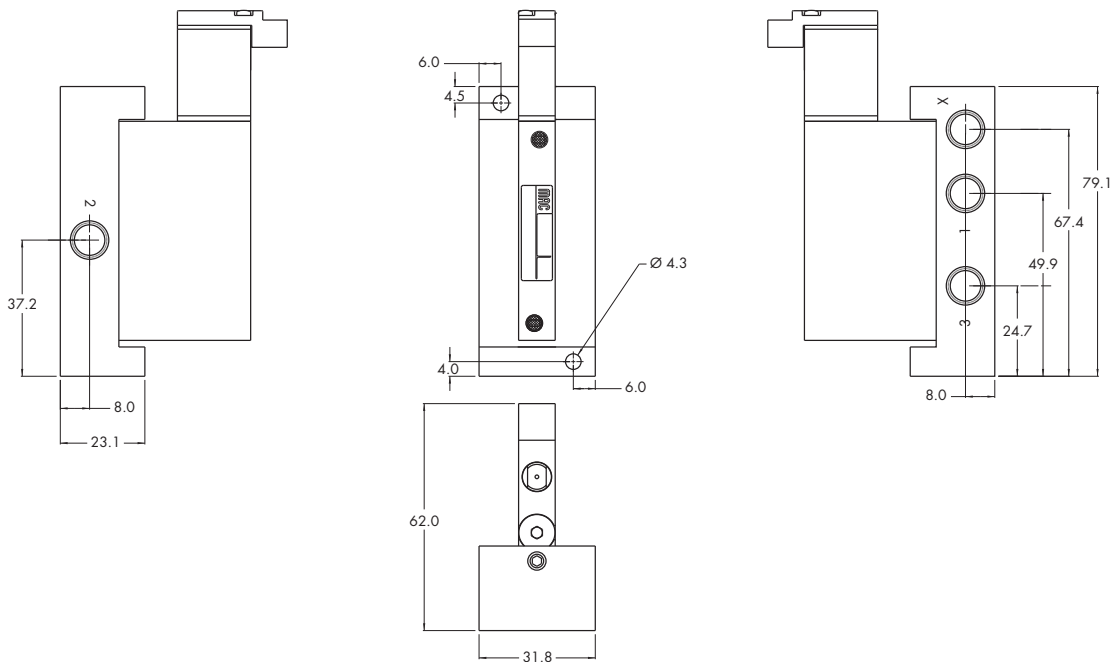

Function	Port size	Flow (Max)	Individual mounting	Series
<b>3/2 NO-NC</b>	<b># 10-32 - 1/4" O.D. tube receptacle</b>	<b>0.4 C<sub>v</sub></b>	Sub-base "plug-in"	

**OPERATIONAL BENEFITS**

1. 3-way valve with 4-way integral pilot.
2. 10 mm valve (stacks on 10.5 mm centers).
3. High flow (up to 0.4 C<sub>v</sub>).
4. Fast, repeatable response times.
5. Maximum shifting forces in both directions.



33  
34  
36  
32  
37  
38  
52  
67  
69  
44  
46  
42  
47  
48P

**HOW TO ORDER**

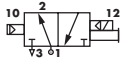
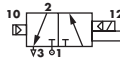
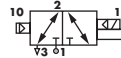
Port size	Pilot air	NO valve	NC valve	Universal valve
				
<b>Valve less base</b>	Internal	32B-BMA-000-GxxP-xxx	32B-AMA-000-GxxP-xxx	
	External	32B-BMB-000-GxxP-xxx	32B-AMB-000-GxxP-xxx	32B-GMB-000-GxxP-xxx
<b># 10-32</b>	Internal	32B-BMA-AAA-GxxP-xxx	32B-AMA-AAA-GxxP-xxx	
	External	32B-BMB-AAB-GxxP-xxx	32B-AMB-AAB-GxxP-xxx	32B-GMB-AAB-GxxP-xxx
<b>1/4" O.D. Tube receptacle</b>	Internal	32B-BMA-EAA-GxxP-xxx	32B-AMA-EAA-GxxP-xxx	
	External	32B-BMB-EAB-GxxP-xxx	32B-AMB-EAB-GxxP-xxx	32B-GMB-EAB-GxxP-xxx

Note : Above codes are for side port.

STANDARD SOLENOID OPERATOR >

G **XX** P-**XXX**\*

XX Voltage	X Manual operator	XX Electrical connection
<b>AA</b> 120 VAC (2.5W)	<b>1</b> Non-locking recessed	<b>SA</b> Base plug-in
<b>DA</b> 24 VDC (1.0W)	<b>2</b> Locking recessed	<b>SJ</b> Base plug-in with light
<b>DC</b> 24 VDC (1.8W)		<b>SS</b> Base plug-in with rectifier & light & ground
<b>DD</b> 24 VDC (2.5W)		
<b>DF</b> 24 VDC (4.0W)		

Note : AC voltage requires connector with rectifier.  
 \* Other options available, see page 311.  
 Latching solenoid also available, see page 43.  
 Washdown capability is possible, consult factory for modification number.

**OPTIONS**

Pilot/Base Configuration :

32B-**xMx-xAx-GxxP-xxx**

- A** Individual base – Side port
- B** Individual base – Bottom port
- M** Pilot exhaust muffled
- P** Pilot exhaust piped (# 10-32)
- U** Pilot exhaust to main exhaust (not available with external pilot)

48  
400  
92  
93  
ISO 01  
ISO 02  
ISO 1  
ISO 2  
ISO 3

**TECHNICAL DATA**

<b>Fluid :</b>	Compressed air, vacuum, inert gases
<b>Pressure range :</b>	Internal Pilot : 20 to 120 PSI External Pilot : Vacuum to 120 PSI
<b>Pilot pressure :</b>	20 to 120 PSI
<b>Lubrication :</b>	Not required, if used select a medium aniline point lubricant (between 180°F and 210°F)
<b>Filtration :</b>	40 μ
<b>Temperature range :</b>	0°F to 120°F (-18°C to +50°C)
<b>Flow :</b>	# 10-32 : (0.35 C <sub>v</sub> ) - 1/4 tube receptacle : (0.40 C <sub>v</sub> )
<b>Coil :</b>	Class A continuous duty, #22 AWG x 12 base leads
<b>Voltage range :</b>	-1.5% to +10% of nominal voltage
<b>Power :</b>	1.0 to 4.0 W
<b>Response times : (with 4 W coil)</b>	Energize : 5 ms De-energize : 5 ms

Options : • M5 port • M7 port • 6 mm O.D. tube receptacle

**DIMENSIONS**

Dimensions shown are metric (mm)

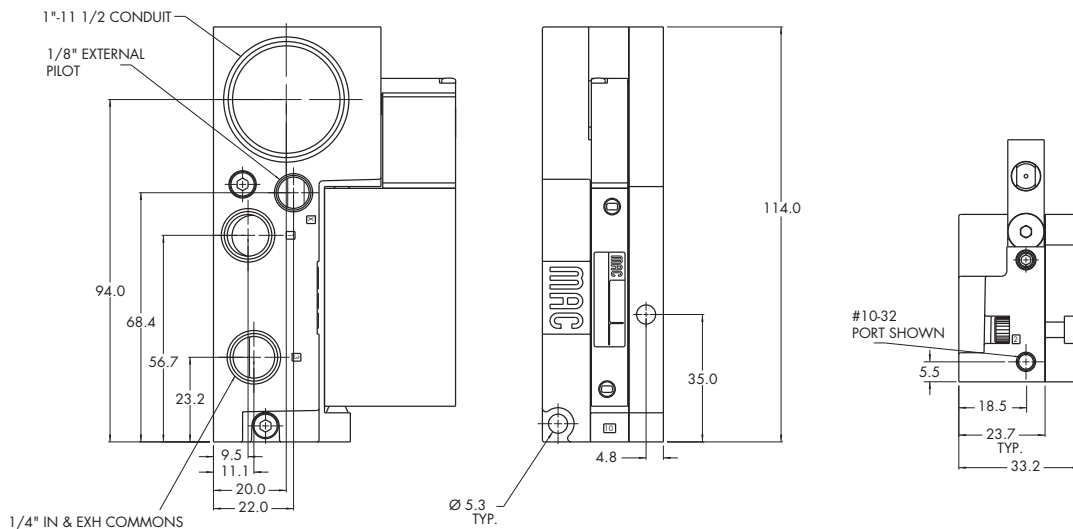



# Direct solenoid and solenoid pilot operated valves

Function	Port size	Flow (Max)	Individual mounting	Series
<b>3/2 NO-NC</b>	<b># 10-32 - 1/4" O.D. tube receptacle</b>	<b>0.4 C<sub>v</sub></b>	Manifold base non "plug-in"	

### OPERATIONAL BENEFITS

1. 3-way valve with 4-way integral pilot.
2. 10 mm valve (stacks on 10.5 mm centers).
3. High flow (up to 0.4 C<sub>v</sub>).
4. Fast, repeatable response times.
5. Maximum shifting forces in both directions.



33  
34  
36  
**32**  
37  
38  
52  
67  
69  
44  
46  
42  
47  
48P

### HOW TO ORDER

Port size	Pilot air	NO valve	NC valve	Universal valve
<b>Valve less base</b>	Internal	32B-BMA-000-Gxxx-xxx	32B-AMA-000-Gxxx-xxx	
	External	32B-BMB-000-Gxxx-xxx	32B-AMB-000-Gxxx-xxx	32B-GMB-000-Gxxx-xxx
<b># 10-32</b>	Internal	32B-BMA-AJL-Gxxx-xxx	32B-AMA-AJL-Gxxx-xxx	
	External	32B-BMB-AJM-Gxxx-xxx	32B-AMB-AJM-Gxxx-xxx	32B-GMB-AJM-Gxxx-xxx
<b>1/4" O.D. Tube receptacle</b>	Internal	32B-BMA-EJL-Gxxx-xxx	32B-AMA-EJL-Gxxx-xxx	
	External	32B-BMB-EJM-Gxxx-xxx	32B-AMB-EJM-Gxxx-xxx	32B-FMB-EJM-Gxxx-xxx

Note : Above codes are for side port.

### STANDARD SOLENOID OPERATOR >

XX Voltage	X Wire length	X Manual operator	XX Electrical connection
AA 120 VAC (2.5W)	A 18"	1 Non-locking recessed	BA Flying leads
DA 24 VDC (1.0W)	B 24"	2 Locking recessed	BT Flying leads with light
DC 24 VDC (1.8W)	C 36"		GA MAC JAC Solenoid plug-in
DD 24 VDC (2.5W)			GB MAC JAC Solenoid plug-in w/Diode
DF 24 VDC (4.0W)			GC MAC JAC Solenoid plug-in w/MOV
			GD MAC JAC Solenoid plug-in w/LED
			GE MAC JAC Solenoid plug-in w/Diode & LED
			GF MAC JAC Solenoid plug-in w/MOV & LED
			GG MAC JAC Solenoid plug-in w/Rectifier
			GH MAC JAC Solenoid plug-in w/Rectifier & LED
			KA Plug-in wire assy.
			KT Plug-in wire assy. with light
			KD Plug-in wire assy. with rectifier & light & ground

Note : AC voltage requires connector with rectifier.

\* Other options available, see page 311.

Latching solenoid also available, see page 41.

With MAC JAC electrical connector washdown capability is possible.

Consult factory for modification number.

### OPTIONS

Base only :

32B-000-xxx  
(i.e. 32B-000-AJL)

Base/Pilot Configuration :

32B-xMx-xJx-Gxxx-xxx

- J Manifold base – Side port
- K Manifold base – Bottom port
- M Pilot exhaust muffled
- P Pilot exhaust piped (# 10-32)
- U Pilot exhaust to main exhaust (not available with external pilot)

Note : Manifold assemblies require an end plate kit :

M-32003-01-01 (Internal pilot)  
M-32003-02-01 (External pilot)

48  
400  
92  
93  
ISO 01  
ISO 02  
ISO 1  
ISO 2  
ISO 3



**TECHNICAL DATA**

<b>Fluid :</b>	Compressed air, vacuum, inert gases
<b>Pressure range :</b>	Internal Pilot : 20 to 120 PSI External Pilot : Vacuum to 120 PSI
<b>Pilot pressure :</b>	20 to 120 PSI
<b>Lubrication :</b>	Not required, if used select a medium aniline point lubricant (between 180°F and 210°F)
<b>Filtration :</b>	40 μ
<b>Temperature range :</b>	0°F to 120°F (-18°C to +50°C)
<b>Flow :</b>	# 10-32 : (0.35 C <sub>v</sub> ) - 1/4 tube receptacle : (0.40 C <sub>v</sub> )
<b>Coil :</b>	Class A wire (#22 AWG x 18), continuous duty
<b>Voltage range :</b>	-1.5% to +10% of nominal voltage
<b>Power :</b>	1.0 to 4.0 W
<b>Response times : (with 4 W coil)</b>	Energize : 5 ms De-energize : 5 ms

- Options :
- M5 port • M7 port • 6 mm O.D. tube receptacle
  - Inlet/Exhaust Isolator : 28454

**DIMENSIONS**

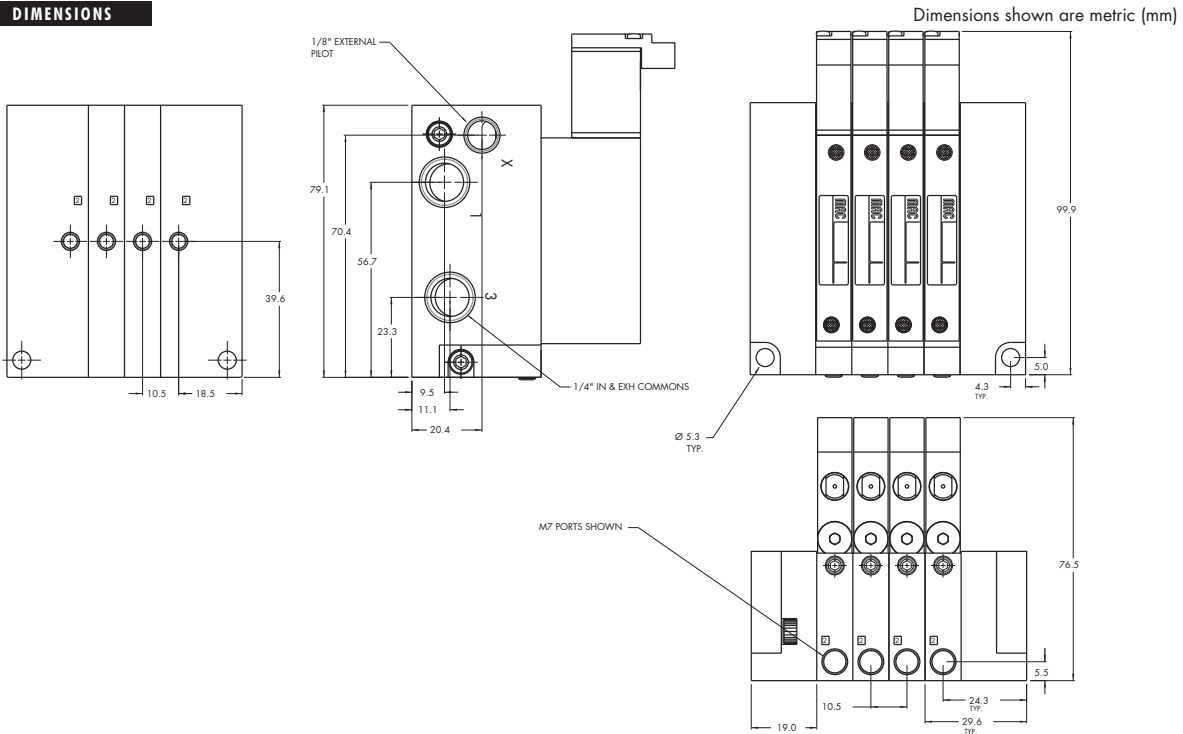



# Direct solenoid and solenoid pilot operated valves

Function	Port size	Flow (Max)	Individual mounting	Series
<b>3/2 NO-NC</b>	<b># 10-32 - 1/4" O.D. tube receptacle</b>	<b>0.4 C<sub>v</sub></b>	Manifold base "plug-in"	

### OPERATIONAL BENEFITS

1. 3-way valve with 4-way integral pilot.
2. 10 mm valve (stacks on 10.5 mm centers).
3. High flow (up to 0.4 C<sub>v</sub>).
4. Fast, repeatable response times.
5. Maximum shifting forces in both directions.



33  
34  
36  
32  
37  
38  
52  
67  
69  
44  
46  
42  
47  
48P

### HOW TO ORDER

Port size	Pilot air	NO valve	NC valve	Universal valve
<b>Valve less base</b>	Internal	32B-BMA-000-GxxP-xxx	32B-AMA-000-GxxP-xxx	
	External	32B-BMB-000-GxxP-xxx	32B-AMB-000-GxxP-xxx	32B-GMB-000-GxxP-xxx
<b># 10-32</b>	Internal	32B-BMA-AJA-GxxP-xxx	32B-AMA-AJA-GxxP-xxx	
	External	32B-BMB-AJB-GxxP-xxx	32B-AMB-AJB-GxxP-xxx	32B-GMB-AJB-GxxP-xxx
<b>1/4" O.D. Tube receptacle</b>	Internal	32B-BMA-EJA-GxxP-xxx	32B-AMA-EJA-GxxP-xxx	
	External	32B-BMB-EJB-GxxP-xxx	32B-AMB-EJB-GxxP-xxx	32B-GMB-EJB-GxxP-xxx

Note : Above codes are for side port.

### STANDARD SOLENOID OPERATOR >

G **XX** P-**XXX**\*

XX Voltage	X Manual operator	XX Electrical connection
<b>AA</b> 120 VAC (2.5W)	<b>1</b> Non-locking recessed	<b>SA</b> Base plug-in
<b>DA</b> 24 VDC (1.0W)	<b>2</b> Locking recessed	<b>SJ</b> Base plug-in with light
<b>DC</b> 24 VDC (1.8W)		<b>SS</b> Base plug-in with rectifier & light & ground
<b>DD</b> 24 VDC (2.5W)		
<b>DF</b> 24 VDC (4.0W)		

Note : AC voltage requires connector with rectifier.

\* Other options available, see page 311.

Latching solenoid also available, see page 43.

Washdown capability is possible, consult factory for modification number.

### OPTIONS

Base only :

32B-000-xxx  
(i.e. 32B-000-AJA)

Base Configuration :

32B-xxx-**J**x-GxxP-xxx

- J** Manifold base – Side port
- K** Manifold base – Bottom port
- L** Left end manifold base – Side port
- M** Left end manifold base – Bottom port
- N** Right end manifold base – Side port
- P** Right end manifold base – Bottom port

Note : Manifold assemblies consist of (1) left end manifold, (1) right end manifold and middle station manifolds (options "J" or "K").

48  
400  
92  
93  
ISO 01  
ISO 02  
ISO 1  
ISO 2  
ISO 3

**TECHNICAL DATA**

<b>Fluid :</b>	Compressed air, vacuum, inert gases
<b>Pressure range :</b>	Internal Pilot : 20 to 120 PSI External Pilot : Vacuum to 120 PSI
<b>Pilot pressure :</b>	20 to 120 PSI
<b>Lubrication :</b>	Not required, if used select a medium aniline point lubricant (between 180°F and 210°F)
<b>Filtration :</b>	40 μ
<b>Temperature range :</b>	0°F to 120°F (-18°C to +50°C)
<b>Flow :</b>	# 10-32 : (0.35 C <sub>v</sub> ) - 1/4 tube receptacle : (0.40 C <sub>v</sub> )
<b>Coil :</b>	Class A continuous duty, #22 AWG x 12 base leads
<b>Voltage range :</b>	-1.5% to +10% of nominal voltage
<b>Power :</b>	1.0 to 4.0 W
<b>Response times : (with 4 W coil)</b>	Energize : 5 ms De-energize : 5 ms

- Options :
- M5 port • M7 port • 6 mm O.D. tube receptacle
  - Inlet/Exhaust Isolator : 28454

**DIMENSIONS**

Dimensions shown are metric (mm)

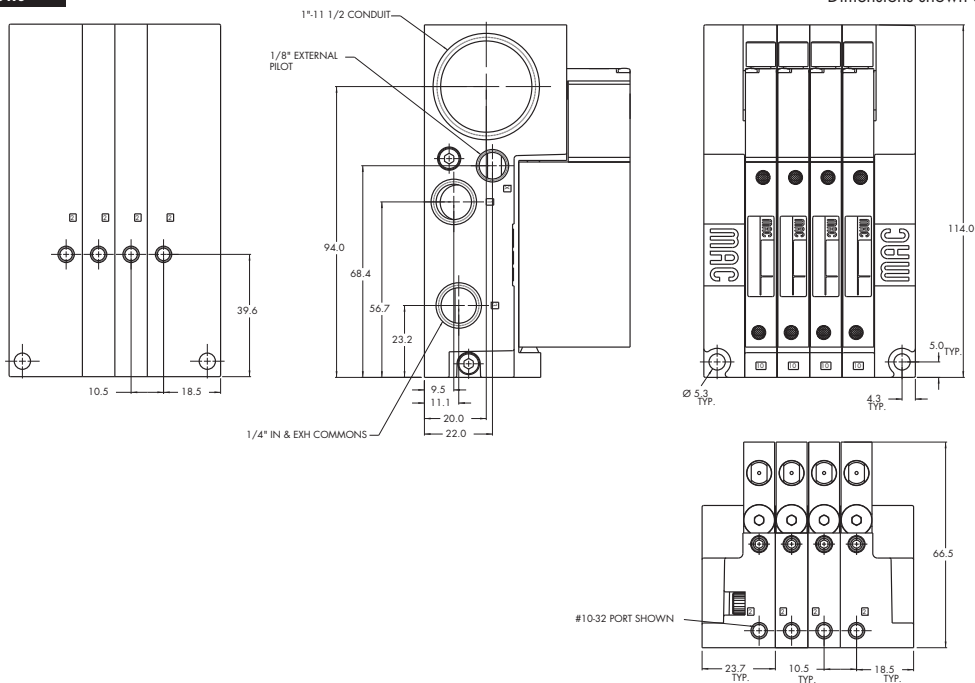

Individual mounting

Series

Inline	Sub-base non plug-in
--------	----------------------

33

34

36

32

**37**

38

52

67

69

44

46

42

47

48P

48

400

92

93

ISO 01

ISO 02

ISO 1

ISO 2

ISO 3

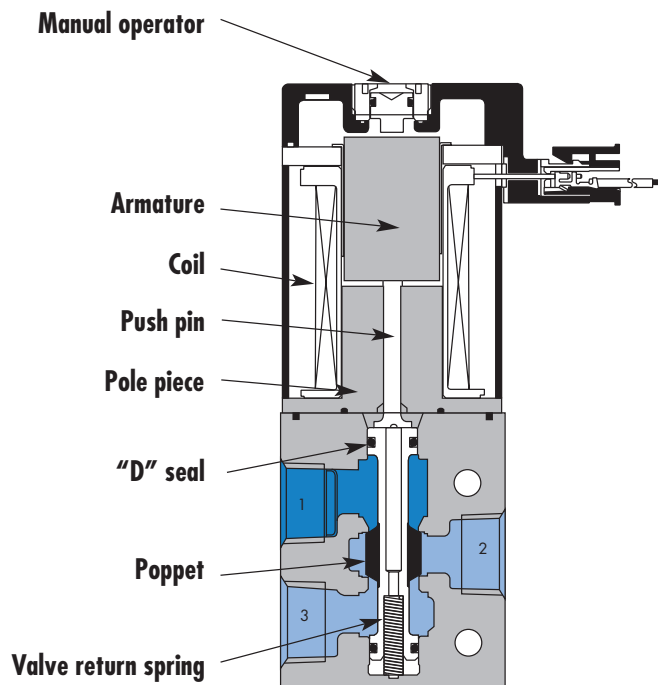

**SERIES FEATURES**

- Balanced poppet equals consistent high shifting forces.
- Valve shifting forces are consistent and independent of pressure fluctuations.
- High solenoid and return spring forces ensure high speed and precise repeatability.
- Built-in wear compensation - valve stroke is shorter than solenoid stroke.
- Constant high flow maintained throughout the pressure range.
- Exhaust contaminants are isolated from the solenoid.
- Full flow exhaust.
- Universal porting - 6 functions in one valve.



# Direct solenoid and solenoid pilot operated valves

Function	Port size	Flow (Max)	Individual mounting	Series
<b>3/2 NO-NC</b>	<b>1/8" - 1/4"</b>	<b>0.5 C<sub>v</sub></b>	Inline	

### OPERATIONAL BENEFITS

- Balanced poppet equals consistent high shifting forces.
- Valve shifting forces are consistent and independent of pressure fluctuations.
- High solenoid and return spring forces ensure high speed and precise repeatability.
- Built-in wear compensation – valve stroke is shorter than solenoid stroke.
- Constant high flow maintained throughout the pressure range.
- Exhaust contaminants are isolated from the solenoid.
- Full flow exhaust.
- Universal porting – 6 functions in one valve.



### HOW TO ORDER

Port size	Universal valve	NC only valve
<b>1/8" NPTF</b>	37A-AA0-H <b>xxx-xxx</b>	37A-BA0-H <b>xxx-xxx</b>
<b>1/4" NPTF</b>	37A-AB0-H <b>xxx-xxx</b>	37A-BB0-H <b>xxx-xxx</b>

### SOLENOID OPERATOR >

H **xxx-xxx\***

XX	Voltage	X	Wire length	X	Manual operator	XX	Electrical connection**
AA	120 VAC (6.7W)	A	18"	1	Non-locking recessed	MA	Plug-in wire assembly
DA	24 VDC (5.2W)	B	24"	2	Locking recessed	MC	Plug-in wire assembly with light
DB	24 VDC (2.4W)					BA	Flying leads
DC	24 VDC (1.8W)					BC	Flying leads with light
						MT	Plug-in wire assembly with rectifier & light

Note : AC voltage requires connector with rectifier.

\* Other options available, see page 315.

- 33
- 34
- 36
- 32
- 37**
- 38
- 52
- 67
- 69
- 44
- 46
- 42
- 47
- 48P
- 48
- 400
- 92
- 93
- ISO 01
- ISO 02
- ISO 1
- ISO 2
- ISO 3

**TECHNICAL DATA**

<b>Fluid :</b>	Compressed air, vacuum, inert gases
<b>Pressure range :</b>	Vacuum to 120 PSI
<b>Lubrication :</b>	Not required, if used select a medium aniline point lubricant (between 180°F and 210°F)
<b>Filtration :</b>	40 μ
<b>Temperature range :</b>	0°F to 120°F (-18°C to +50°C)
<b>Flow :</b>	5.2 W : (0.5 C <sub>v</sub> ) – 2.4 W : (0.35 C <sub>v</sub> )
<b>Coil :</b>	Class A wire (#22 AWG x 18), continuous duty
<b>Voltage range :</b>	-1.5% to +10% of nominal voltage
<b>Power :</b>	5.2 W – 2.4 W
<b>Response times : (with 5.2 W coil)</b>	Energize : 16.9 ms De-energize : 6.7 ms

Options : • BSPP ports

**DIMENSIONS**

Dimensions shown are metric (mm)

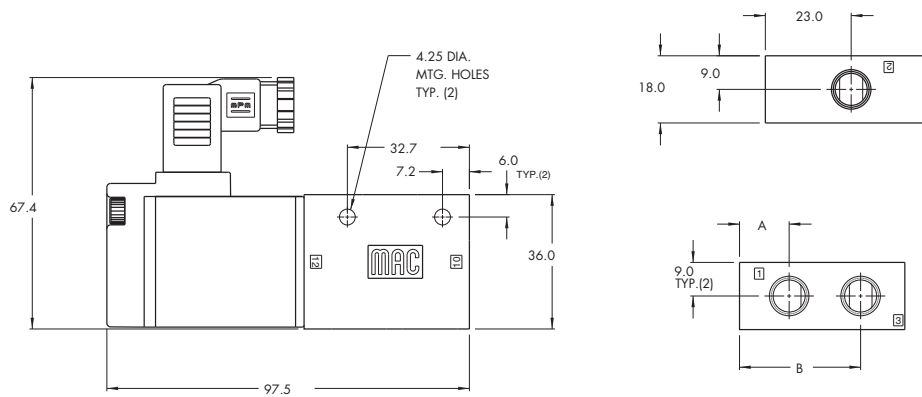

Shown with Mini Square Connector ("K" Type)

Dim	A	B
<b>1/8"</b>	13.3	32.45
<b>1/4"</b>	14.7	33.7

Function	Port size	Flow (Max)	Individual mounting	Series
<b>3/2 NO-NC</b>	<b>1/8" - 1/4"</b>	<b>0.5 C<sub>v</sub></b>	Sub-base non plug-in	

**OPERATIONAL BENEFITS**

- Balanced poppet equals consistent high shifting forces.
- Valve shifting forces are consistent and independent of pressure fluctuations.
- High solenoid and return spring forces ensure high speed and precise repeatability.
- Built-in wear compensation – valve stroke is shorter than solenoid stroke.
- Constant high flow maintained throughout the pressure range.
- Exhaust contaminants are isolated from the solenoid.
- Full flow exhaust.
- Universal porting – 6 functions in one valve.



33  
34  
36  
32

**HOW TO ORDER**

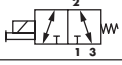
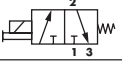
Port size	Universal valve	NC only valve
		
<b>Valve less base</b>	37A-C10-H xxx-xxx	37A-D10-H xxx-xxx
<b>1/8" NPTF</b>	37A-CAA-H xxx-xxx	37A-DAA-H xxx-xxx
<b>1/4" NPTF</b>	37A-CBA-H xxx-xxx	37A-DBA-H xxx-xxx

37  
38  
52  
67  
69  
44

**SOLENOID OPERATOR** ▶

H **xxx-xxx\***

XX Voltage	X Wire length	X Manual operator	XX Electrical connection
<b>AA</b> 120 VAC (6.7W)	<b>A</b> 18"	<b>1</b> Non-locking recessed	<b>MA</b> Plug-in wire assembly
<b>DA</b> 24 VDC (5.2W)	<b>B</b> 24"	<b>2</b> Locking recessed	<b>MC</b> Plug-in wire assembly with light
<b>DB</b> 24 VDC (2.4W)			<b>BA</b> Flying leads
<b>DC</b> 24 VDC (1.8W)			<b>BC</b> Flying leads with light
			<b>MT</b> Plug-in wire assembly with rectifier & light

47  
48P  
48  
400  
92

Note : AC voltage requires connector with rectifier.  
\* Other options available, see page 315.

**OPTIONS**

Base only :

37A-0AA (1/8")
37A-0BA (1/4")

93  
ISO 01  
ISO 02  
ISO 1  
ISO 2  
ISO 3

**TECHNICAL DATA**

<b>Fluid :</b>	Compressed air, vacuum, inert gases
<b>Pressure range :</b>	Vacuum to 120 PSI
<b>Lubrication :</b>	Not required, if used select a medium aniline point lubricant (between 180°F and 210°F)
<b>Filtration :</b>	40 μ
<b>Temperature range :</b>	0°F to 120°F (-18°C to +50°C)
<b>Flow :</b>	5.2 W : (0.5 C <sub>v</sub> ) – 2.4 W : (0.35 C <sub>v</sub> )
<b>Coil :</b>	Class A wire (#22 AWG x 18), continuous duty
<b>Voltage range :</b>	-1.5% to +10% of nominal voltage
<b>Power :</b>	5.2 W – 2.4 W
<b>Response times :</b>	Energize : 16.9 ms
<b>(with 5.2 W coil)</b>	De-energize : 6.7 ms

Options : • BSPP ports • Sandwich regulator - see "Regulator" Section

**DIMENSIONS**

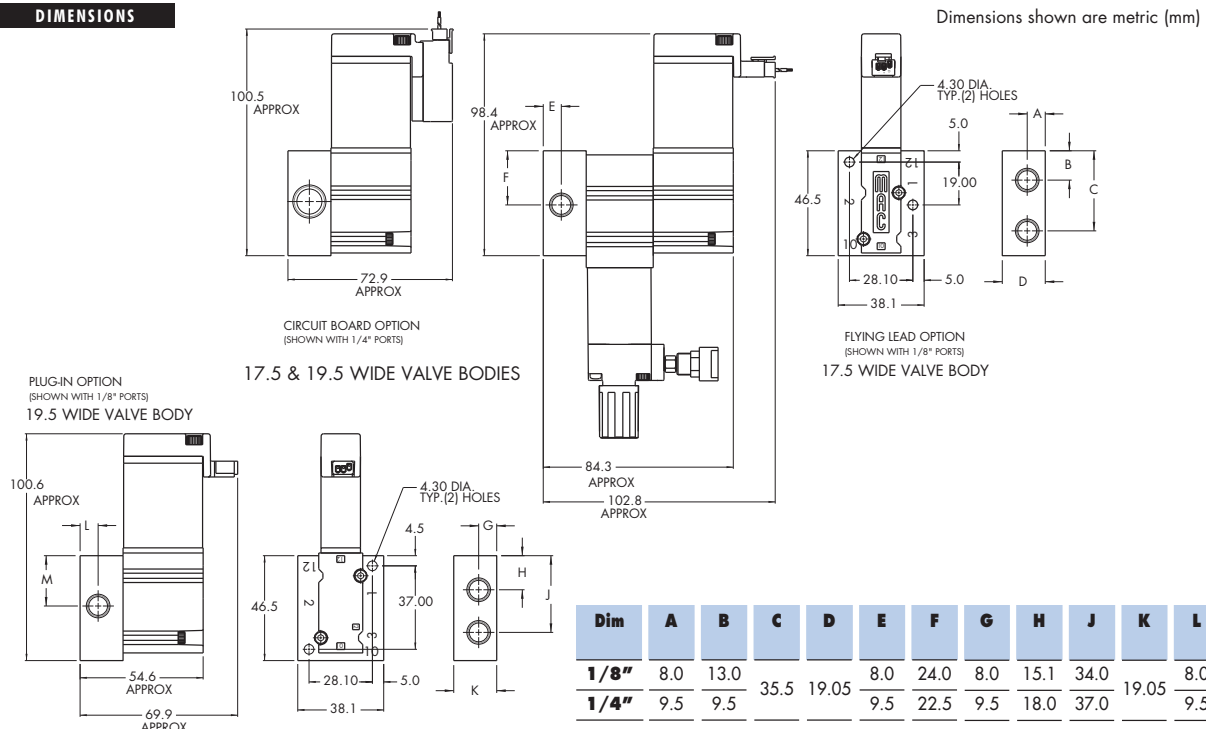



Individual mounting

Sub-base non "plug-in"	Sub-base "plug-in"	Sub-base/manifold base non "plug-in" with latching solenoid	Sub-base/manifold base "plug-in" with latching solenoid
------------------------	--------------------	---	---

Series

Manifold mounting

Manifold base "plug-in"	Sub-base/manifold base non "plug-in" with latching solenoid	Sub-base/manifold base "plug-in" with latching solenoid
-------------------------	---	---

33

34

36

32

37

**38**

52

67

69

44

46

42

47

48P

48

400

92

93

ISO 01

ISO 02

ISO 1

ISO 2

ISO 3

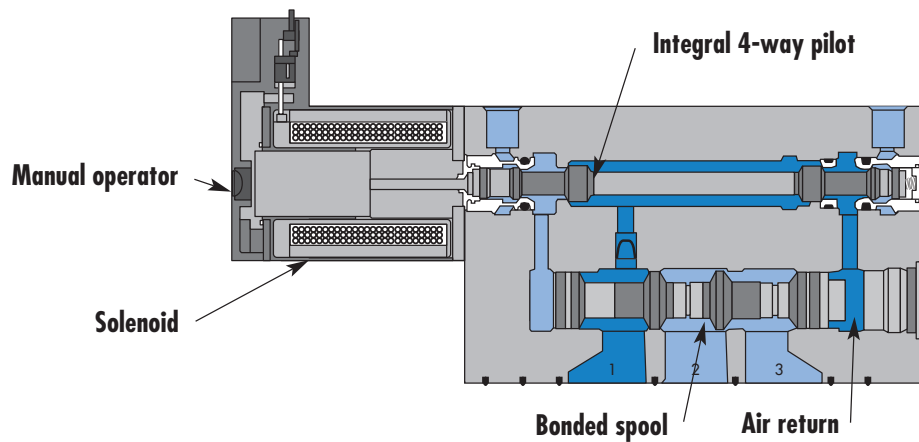

**SERIES FEATURES**

- High force MACSOLENOID®.
- Integral 4-way pilot design.
- Internal or external pilot.
- Normally open or normally closed function.
- Universal function (external pilot).
- Rectified AC voltage.
- Latching solenoid technology.

Function	Port size	Flow (Max)	Individual mounting	Series
<b>3/2 NO-NC</b>	<b>1/8"</b>	<b>1.2 C<sub>v</sub></b>	Sub-base non "plug-in"	

### OPERATIONAL BENEFITS

1. 3-way valve with 4-way integral pilot.
2. 10 mm valve (stacks on 16.5 mm centers).
3. High flow (up to 1.2 Cv).
4. Fast, repeatable response times.
5. Maximum shifting forces in both directions.



33  
34  
36  
32  
37  
**38**

### HOW TO ORDER

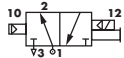
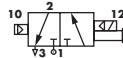
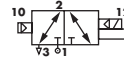
Port size	Pilot air	NO valve	NC valve	Universal valve
				
<b>Valve less base</b>	Internal	38B-BMA-000-Gxxx-xxx	38B-AMA-000-Gxxx-xxx	
	External	38B-BMB-000-Gxxx-xxx	38B-AMB-000-Gxxx-xxx	38B-GMB-000-Gxxx-xxx
<b>1/8" NPTF</b>	Internal	38B-BMA-AAL-Gxxx-xxx	38B-AMA-AAL-Gxxx-xxx	
	External	38B-BMB-AAM-Gxxx-xxx	38B-AMB-AAM-Gxxx-xxx	38B-GMB-AAM-Gxxx-xxx

Note : Above codes are for side port.

### STANDARD SOLENOID OPERATOR >

G **XXX-XXX**\*

XX	Voltage	X	Wire length	X	Manual operator	XX	Electrical connection
AA	120 VAC (2.5W)	A	18"	1	Non-locking recessed	BA	Flying leads
DA	24 VDC (1.0W)	B	24"	2	Locking recessed	BT	Flying leads with light
DC	24 VDC (1.8W)	C	36"			GA	MAC JAC Solenoid plug-in
DD	24 VDC (2.5W)					GB	MAC JAC Solenoid plug-in w/Diode
DF	24 VDC (4.0W)					GC	MAC JAC Solenoid plug-in w/MOV
						GD	MAC JAC Solenoid plug-in w/LED
						GE	MAC JAC Solenoid plug-in w/Diode & LED
						GF	MAC JAC Solenoid plug-in w/MOV & LED
						GG	MAC JAC Solenoid plug-in w/Rectifier
						GH	MAC JAC Solenoid plug-in w/Rectifier & LED
						KA	Plug-in wire assembly
						KT	Plug-in wire assembly with light
						KD	Plug-in wire assembly with rectifier & light & ground

Note : AC voltage requires connector with rectifier.

\* Other options available, see page 311.

Latching solenoid also available, see page 59.

With MAC JAC electrical connector washdown capability is possible.

Consult factory for modification number.

### OPTIONS

Pilot/Base Configuration :

38B-xMx-xAx-Gxxx-xxx

- A Individual base – Side port
- B Individual base – Bottom port
- M Pilot exhaust muffled
- P Pilot exhaust piped (# 10-32)
- U Pilot exhaust to main exhaust

46  
42  
47  
48P  
48  
400  
92  
93  
ISO 01  
ISO 02  
ISO 1  
ISO 2  
ISO 3

**TECHNICAL DATA**

<b>Fluid :</b>	Compressed air, vacuum, inert gases
<b>Pressure range :</b>	Internal Pilot : 20 to 120 PSI External Pilot : Vacuum to 120 PSI
<b>Pilot pressure :</b>	20 to 120 PSI
<b>Lubrication :</b>	Not required, if used select a medium aniline point lubricant (between 180°F and 210°F)
<b>Filtration :</b>	40 $\mu$
<b>Temperature range :</b>	0°F to 120°F (-18°C to +50°C)
<b>Flow :</b>	1/8" bottom port: (1.2 C <sub>v</sub> ) - 1/8" side port: (1.0 C <sub>v</sub> )
<b>Coil :</b>	Class A wire (#22 AWG x 18), continuous duty
<b>Voltage range :</b>	-15% to +10% of nominal voltage
<b>Power :</b>	1.0 to 4.0 W
<b>Response times : (with 4 W coil)</b>	Energize : 6 ms De-energize : 6 ms

Options : • BSPP threads

**DIMENSIONS**

Dimensions shown are metric (mm)

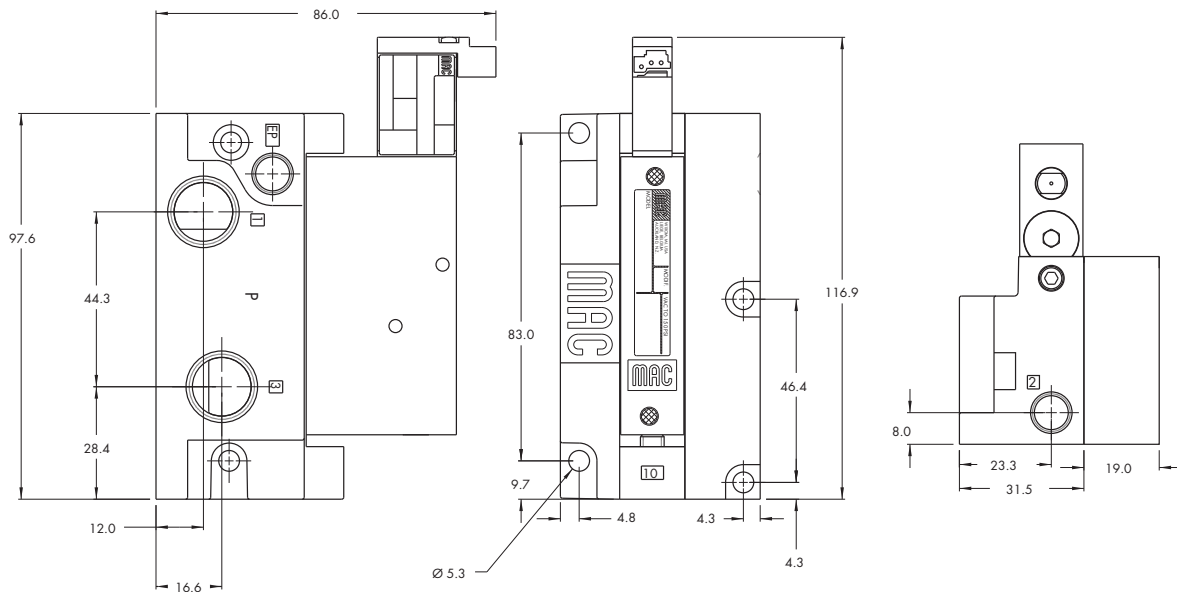



# Direct solenoid and solenoid pilot operated valves

Function	Port size	Flow (Max)	Individual mounting	Series
<b>3/2 NO-NC</b>	<b>1/8" - 1/4" O.D. tube receptacle</b>	<b>1.2 C<sub>v</sub></b>	Sub-base "plug-in"	

### OPERATIONAL BENEFITS

1. 3-way valve with 4-way integral pilot.
2. 10 mm valve (stacks on 16.5 mm centers).
3. High flow (up to 1.2 C<sub>v</sub>).
4. Fast, repeatable response times.
5. Maximum shifting forces in both directions.



33  
34  
36  
32  
37  
**38**

### HOW TO ORDER

Port size	Pilot air	NO valve	NC valve	Universal valve
<b>Valve less base</b>	Internal	38B-BMA-000-GxxP-xxx	38B-AMA-000-GxxP-xxx	
	External	38B-BMB-000-GxxP-xxx	38B-AMB-000-GxxP-xxx	38B-GMB-000-GxxP-xxx
<b>1/8" NPTF</b>	Internal	38B-BMA-AAA-GxxP-xxx	38B-AMA-AAA-GxxP-xxx	
	External	38B-BMB-AAB-GxxP-xxx	38B-AMB-AAB-GxxP-xxx	38B-GMB-BAB-GxxP-xxx
<b>1/4" O.D. Tube receptacle</b>	Internal	38B-BMA-EAA-GxxP-xxx	38B-AMA-EAA-GxxP-xxx	
	External	38B-BMB-EAB-GxxP-xxx	38B-AMB-EAB-GxxP-xxx	38B-GMB-EAB-GxxP-xxx

Note : Above codes are for side port.

### STANDARD SOLENOID OPERATOR >

G **XX** P-**XXX**\*

XX Voltage	X Manual operator	XX Electrical connection
AA 120 VAC (2.5W)	1 Non-locking recessed	SA Base plug-in
DA 24 VDC (1.0W)	2 Locking recessed	SJ Base plug-in with light
DC 24 VDC (1.8W)		SS Base plug-in with rectifier & light & ground
DD 24 VDC (2.5W)		
DF 24 VDC (4.0W)		

Note : AC voltage requires connector with rectifier.  
\* Other options available, see page 311.  
Latching solenoid also available, see page 61.

46  
42  
47  
48P  
48

### OPTIONS

Pilot/Base Configuration :

38B-xMx-xAx-GxxP-xxx

- A Individual base – Side port
- B Individual base – Bottom port
- M Pilot exhaust muffled
- P Pilot exhaust piped (# 10-32)
- U Pilot exhaust to main exhaust

Washdown capability is possible, consult factory for modification number.

400  
92  
93  
ISO 01  
ISO 02  
ISO 1  
ISO 2  
ISO 3

**TECHNICAL DATA**

<b>Fluid :</b>	Compressed air, vacuum, inert gases
<b>Pressure range :</b>	Internal Pilot : 20 to 120 PSI External Pilot : Vacuum to 120 PSI
<b>Pilot pressure :</b>	20 to 120 PSI
<b>Lubrication :</b>	Not required, if used select a medium aniline point lubricant (between 180°F and 210°F)
<b>Filtration :</b>	40 μ
<b>Temperature range :</b>	0°F to 120°F (-18°C to +50°C)
<b>Flow :</b>	1/8" bottom port: (1.2 C <sub>v</sub> ) - 1/8" side port: (1.0 C <sub>v</sub> ) - 1/4" tube receptacle: (0.85 C <sub>v</sub> )
<b>Coil :</b>	Class A continuous duty, #22 AWG x 12 base leads
<b>Voltage range :</b>	-1.5% to +10% of nominal voltage
<b>Power :</b>	1.0 to 4.0 W
<b>Response times : (with 4 W coil)</b>	Energize : 6 ms De-energize : 6 ms

Options : • BSPP threads

**DIMENSIONS**

Dimensions shown are metric (mm)

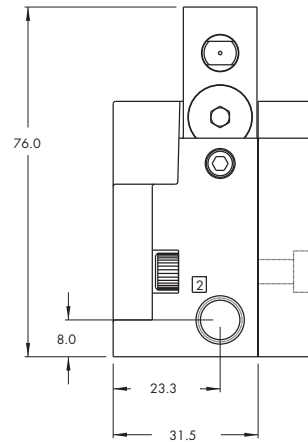
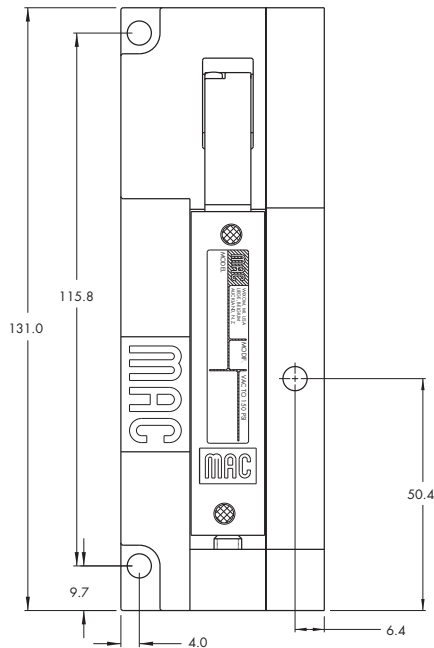



# Direct solenoid and solenoid pilot operated valves

Function	Port size	Flow (Max)	Manifold mounting	Series
<b>3/2 NO-NC</b>	<b>1/8" - 1/4" O.D. tube receptacle</b>	<b>1.2 C<sub>v</sub></b>	Manifold base "plug-in"	

### OPERATIONAL BENEFITS

1. 3-way valve with 4-way integral pilot.
2. 10 mm valve (stacks on 16.5 mm centers).
3. High flow (up to 1.2 C<sub>v</sub>).
4. Fast, repeatable response times.
5. Maximum shifting forces in both directions.



33  
34  
36  
32  
37  
**38**

### HOW TO ORDER

Port size	Pilot air	NO valve	NC valve	Universal valve
<b>Valve less base</b>	Internal	38B-BMA-000-GxxP-xxx	38B-AMA-000-GxxP-xxx	
	External	38B-BMB-000-GxxP-xxx	38B-AMB-000-GxxP-xxx	38B-GMB-000-GxxP-xxx
<b>1/8" NPTF</b>	Internal	38B-BMA-AJA-GxxP-xxx	38B-AMA-AJA-GxxP-xxx	
	External	38B-BMB-AJB-GxxP-xxx	38B-AMB-AJB-GxxP-xxx	38B-GMB-BJB-GxxP-xxx
<b>1/4" O.D. Tube receptacle</b>	Internal	38B-BMA-EJA-GxxP-xxx	38B-AMA-EJA-GxxP-xxx	
	External	38B-BMB-EJB-GxxP-xxx	38B-AMB-EJB-GxxP-xxx	38B-GMB-EJB-GxxP-xxx

52  
67  
69  
44  
46  
42  
47  
**48P**

Note : Above codes are for side port.

### STANDARD SOLENOID OPERATOR >

G **XX** P-**XXX**\*

XX Voltage	X Manual operator	XX Electrical connection
<b>AA</b> 120 VAC (2.5W)	<b>1</b> Non-locking recessed	<b>SA</b> Base plug-in
<b>DA</b> 24 VDC (1.0W)	<b>2</b> Locking recessed	<b>SJ</b> Base plug-in with light
<b>DC</b> 24 VDC (1.8W)		<b>SS</b> Base plug-in with rectifier & light & ground
<b>DD</b> 24 VDC (2.5W)		
<b>DF</b> 24 VDC (4.0W)		

48  
400  
92

Note : AC voltage requires connector with rectifier.  
\* Other options available, see page 311.  
Latching solenoid also available, see page 61.  
Washdown capability is possible, consult factory for modification number.

### OPTIONS

Base only :

38B-000-xxx  
(i.e. 38B-000-AJA)

Base Configuration :

38B-xxx-xJx-GxxP-xxx

- J** Manifold base – Side port
- K** Manifold base – Bottom port
- L** Left end manifold base – Side port
- M** Left end manifold base – Bottom port
- N** Right end manifold base – Side port
- P** Right end manifold base – Bottom port

Note : Manifold assemblies consist of (1) left end manifold, (1) right end manifold and middle station manifolds (options "J" or "K").

93  
ISO 01  
ISO 02  
ISO 1  
ISO 2  
ISO 3

**TECHNICAL DATA**

<b>Fluid :</b>	Compressed air, vacuum, inert gases
<b>Pressure range :</b>	Internal Pilot : 20 to 120 PSI External Pilot : Vacuum to 120 PSI
<b>Pilot pressure :</b>	20 to 120 PSI
<b>Lubrication :</b>	Not required, if used select a medium aniline point lubricant (between 180°F and 210°F)
<b>Filtration :</b>	40 μ
<b>Temperature range :</b>	0°F to 120°F (-18°C to +50°C)
<b>Flow :</b>	1/8" bottom port: (1.2 C <sub>v</sub> ) - 1/8" side port: (1.0 C <sub>v</sub> ) - 1/4" tube receptacle: (0.85 C <sub>v</sub> )
<b>Coil :</b>	Class A continuous duty, #22 AWG x 12 base leads
<b>Voltage range :</b>	-15% to +10% of nominal voltage
<b>Power :</b>	1.0 to 4.0 W
<b>Response times : (with 4 W coil)</b>	Energize : 6 ms De-energize : 6 ms

Options : • BSPP threads

**DIMENSIONS**

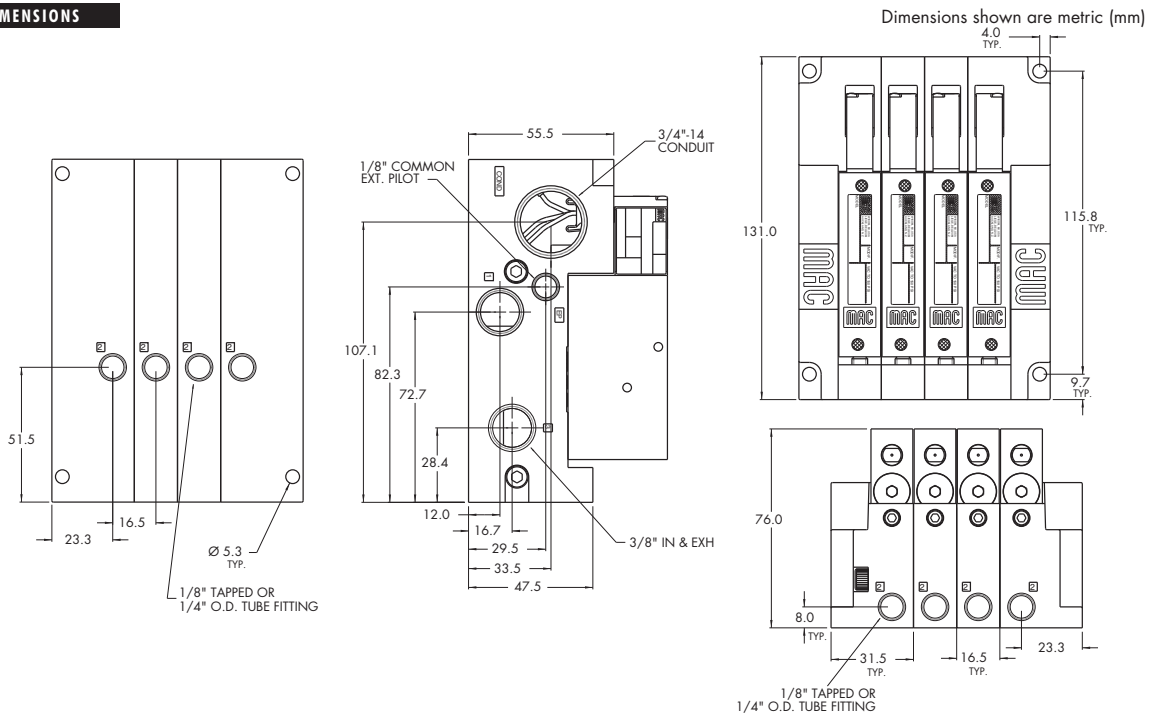

Individual mounting

Series

Inline	
--------	--

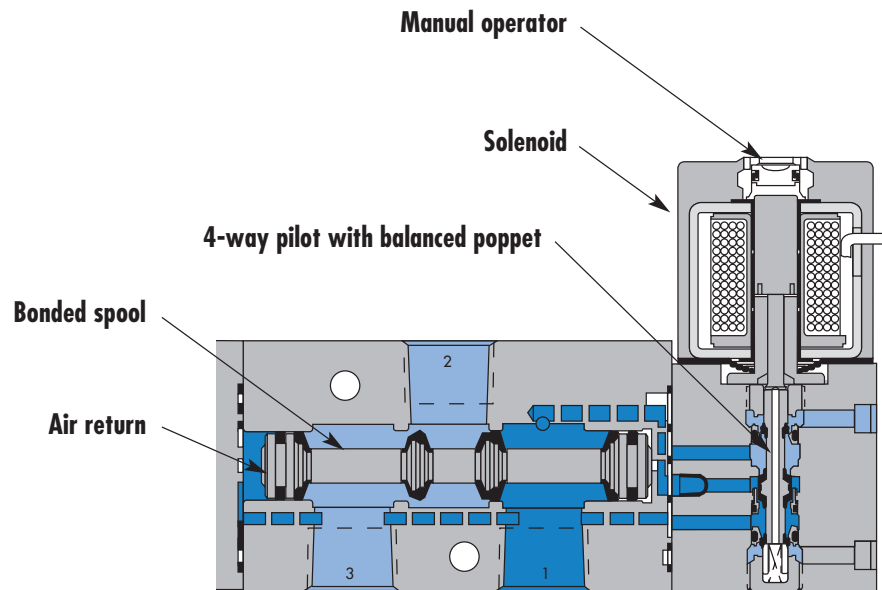

33  
34  
36  
32  
37  
38  
**52**  
67  
69  
44  
46  
42  
47  
48P  
48  
400  
92  
93  
ISO 01  
ISO 02  
ISO 1  
ISO 2  
ISO 3

**SERIES FEATURES**

- Patented MACSOLENOID® for fastest possible response times and virtually burn-out proof AC solenoid operation.
- Optional low watt DC solenoids.
- Various manual operators.
- Optional memory spring.
- Normally closed or normally open valve function.
- May be plugged for 2-way operation.
- Internal or external pilot.



**SPOOL CONFIGURATIONS**

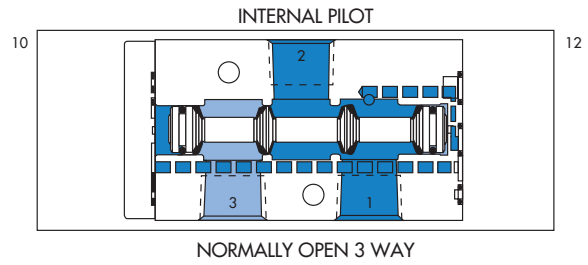
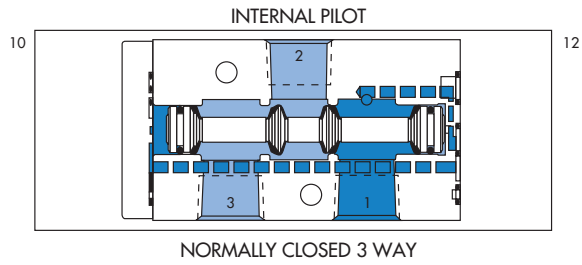

Function	Port size	Flow (Max)	Individual mounting	Series
<b>3/2 NO-NC, 2/2 NO-NC</b>	<b>1/8" - 1/4"</b>	<b>1.5 C<sub>v</sub></b>	Inline	

### OPERATIONAL BENEFITS

1. The 4-way pilot develops maximum shifting force both ways.
2. Memory spring available.
3. Balanced spool, immune to variations of pressure, also provides high flow.
4. Short stroke with high flow.
5. Bonded spool with minimum friction, shifting in a glass-like finished bore.
6. Pilot with balanced poppet, high flow, short and consistent response times.
7. Wiping effect eliminates sticking.
8. Long service life.

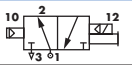
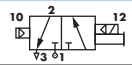
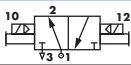
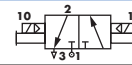

### HOW TO ORDER

Port size	Pilot air	Single Operator		Double Operator	
		NO Valve	NC Valve	NO Valve	NC Valve
					
<b>1/8" NPTF</b>	Internal	52A-31-A0A-XX-X-xxx-xxx	52A-11-A0A-XX-X-xxx-xxx	52A-41-A0A-XX-X-xxx-xxx	52A-21-A0A-XX-X-xxx-xxx
<b>1/4" NPTF</b>	Internal	52A-31-B0A-XX-X-xxx-xxx	52A-11-B0A-XX-X-xxx-xxx	52A-41-B0A-XX-X-xxx-xxx	52A-21-B0A-XX-X-xxx-xxx
<b>1/8" NPTF</b>	External	52A-31-A0B-XX-X-xxx-xxx	52A-11-A0B-XX-X-xxx-xxx	52A-41-A0B-XX-X-xxx-xxx	52A-21-A0B-XX-X-xxx-xxx
<b>1/4" NPTF</b>	External	52A-31-B0B-XX-X-xxx-xxx	52A-11-B0B-XX-X-xxx-xxx	52A-41-B0B-XX-X-xxx-xxx	52A-21-B0B-XX-X-xxx-xxx

### SOLENOID OPERATOR >

#### DM-D XXX-XXX\*

XX Voltage	X Wire length	X Manual operator	XX Electrical connection
<b>JA</b> 110/50, 120/60 (2.9W)	<b>A</b> 18" (Flying leads)	<b>1</b> Non-locking recessed	<b>KA</b> Square connector
<b>JB</b> 220/50, 240/60 (2.9W)	<b>B</b> 24" (Flying leads)	<b>2</b> Locking recessed	<b>KD</b> Square connector with light
<b>JC</b> 24/60 (2.9W)	<b>J</b> Connector		<b>JB</b> Rectangular connector
<b>FB</b> 24 VDC (1.8W)			<b>JD</b> Rectangular connector with light
<b>DA</b> 24 VDC (5.4W)			<b>BA</b> Flying leads
<b>DF</b> 24 VDC (12.7W)			

### SOLENOID OPERATOR >

#### GM-G XXX-XXX\*\*

XX Voltage	X Wire length	X Manual operator	XX Electrical connection
<b>DC</b> 24 VDC (1.8W)	<b>A</b> 18"	<b>1</b> Non-locking recessed	<b>BA</b> Flying leads
<b>DD</b> 24 VDC (2.5W)	<b>B</b> 24"	<b>2</b> Locking recessed	<b>BT</b> Flying leads with light
<b>DF</b> 24 VDC (4.0W)	<b>C</b> 36"		<b>KA</b> Plug-in wire assy.
			<b>KT</b> Plug-in wire assy. with light

\* Other options available, see page 309.  
 \*\* Other options available, see page 313.

### OPTIONS

52A-31-A0A-XX-X-xxx-xxx

For memory spring, replace by **4** (single solenoid only)

33  
34  
36  
32  
37  
38  
**52**  
67  
69  
44  
46  
42  
47  
48P  
48  
400  
92  
93  
ISO 01  
ISO 02  
ISO 1  
ISO 2  
ISO 3

**TECHNICAL DATA**

<b>Fluid :</b>	Compressed air, vacuum, inert gases	
<b>Pressure range :</b>	Internal Pilot : 20 to 120 PSI External Pilot : Vacuum to 120 PSI	
<b>Lubrication :</b>	Not required, if used select a medium aniline point lubricant (between 180°F and 210°F)	
<b>Filtration :</b>	40 µ	
<b>Temperature range :</b>	0°F to 120°F (-18°C to +50°C)	
<b>Flow :</b>	1/8" : (1.2 C <sub>v</sub> ) – 1/4" : (1.5 C <sub>v</sub> )	
<b>Coil :</b>	Class A continuous duty, #22 AWG x 18 lead wires	
<b>Voltage range :</b>	-15% to +10% of nominal voltage	
<b>Protection :</b>	Consult factory	
<b>Power :</b>	~Inrush: 10.9 VA    Holding: 7.7 VA = 1.8 to 12.7 W	
<b>Response times :</b>	24V=5.4W	Energize: 7.3 ms    De-energize: 5.3 ms 120/60    Energize: 8-12 ms    De-energize: 7-11 ms

Options :                    • BSPP threads

**DIMENSIONS**

Dimensions shown are metric (mm)

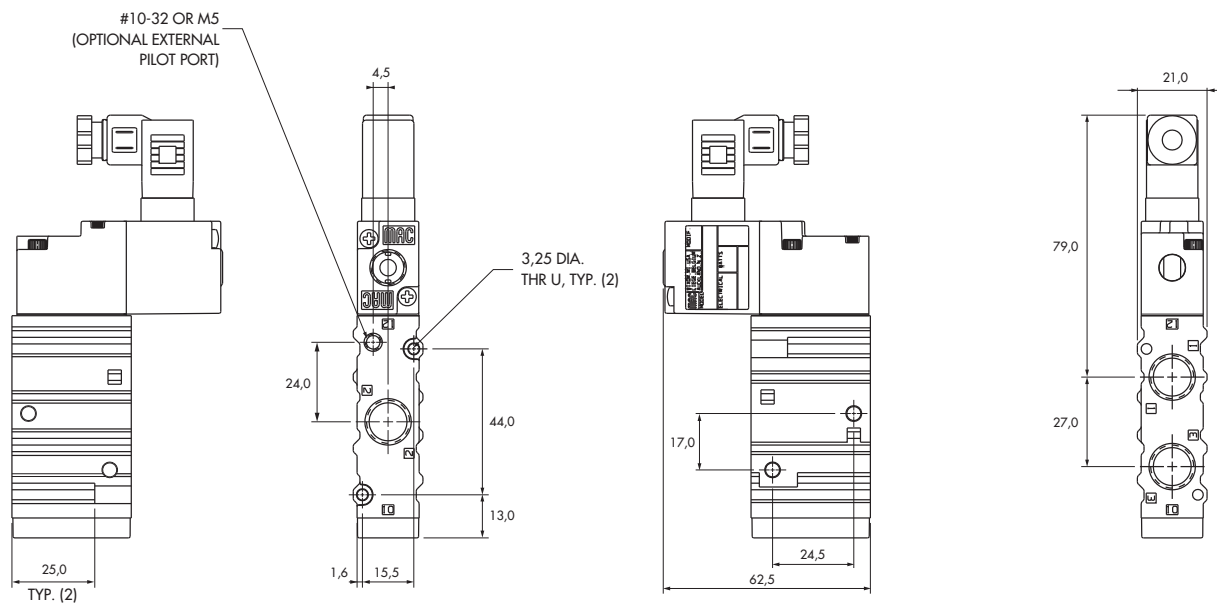

Individual mounting

Inline	
--------	--

Series

- 33
- 34
- 36
- 32
- 37
- 38
- 52
- 67
- 69
- 44
- 46
- 42
- 47
- 48P
- 48
- 400
- 92
- 93

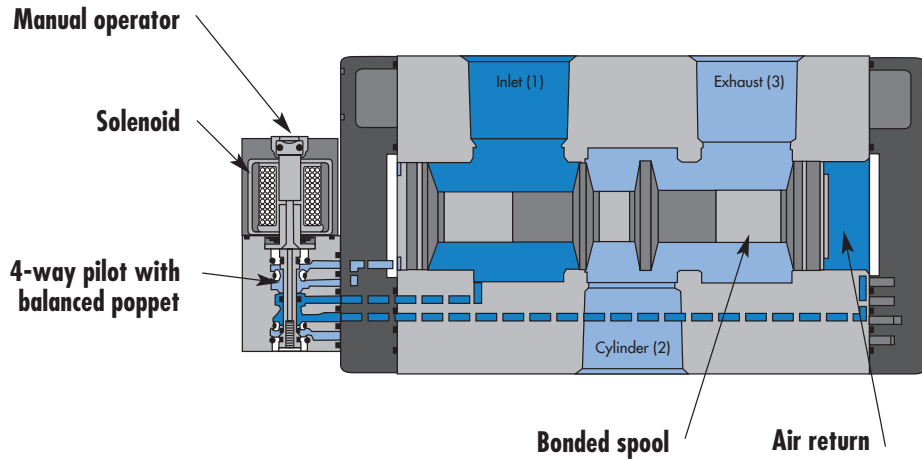

**SERIES FEATURES**

- Patented MACSOLENOID® for fastest possible response times and virtually burn-out proof AC solenoid operation.
- Optional low watt DC solenoids.
- Normally closed or normally open valve function.
- Optional universal spool.
- Internal or external pilot.
- Optional memory spring.
- Checked accumulator.
- Optional pilot exhaust to main valve exhaust.
- May be plugged for 2-way operation.

- ISO 01
- ISO 02
- ISO 1
- ISO 2
- ISO 3

Function	Port size	Flow (Max)	Individual mounting	Series
<b>3/2 NO-NC, 2/2 NO-NC</b>	<b>3/4" - 1"</b>	<b>20.0 C<sub>v</sub></b>	Inline	

### OPERATIONAL BENEFITS

1. The 4-way pilot develops maximum shifting force both ways.
2. Memory spring available.
3. Balanced spool, immune to variations of pressure, also provides high flow.
4. Short stroke with high flow.
5. Bonded spool with minimum friction, shifting in a glass-like finished bore.
6. Pilot with balanced poppet, high flow, short and consistent response times.
7. Wiping effect eliminates sticking.

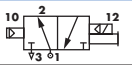
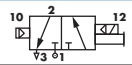
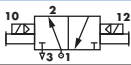
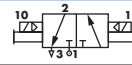

### HOW TO ORDER

Port size	Pilot air	Single Operator		Double Operator	
		NO Valve	NC Valve	NO Valve	NC Valve
					
<b>3/4" NPTF</b>	Internal	67A-Cx-AAA-DM-Dxxx-xxx	67A-Ax-AAA-DM-Dxxx-xxx	67A-Dx-AAA-DM-Dxxx-xxx	67A-Bx-AAA-DM-Dxxx-xxx
<b>1" NPTF</b>	Internal	67A-Cx-BAA-DM-Dxxx-xxx	67A-Ax-BAA-DM-Dxxx-xxx	67A-Dx-BAA-DM-Dxxx-xxx	67A-Bx-BAA-DM-Dxxx-xxx
<b>3/4" NPTF</b>	External	67A-Cx-AAB-DM-Dxxx-xxx	67A-Ax-AAB-DM-Dxxx-xxx	67A-Dx-AAB-DM-Dxxx-xxx	67A-Bx-AAB-DM-Dxxx-xxx
<b>1" NPTF</b>	External	67A-Cx-BAB-DM-Dxxx-xxx	67A-Ax-BAB-DM-Dxxx-xxx	67A-Dx-BAB-DM-Dxxx-xxx	67A-Bx-BAB-DM-Dxxx-xxx

### SOLENOID OPERATOR ▶

### DM-D **XXX-XXX**\*

XX Voltage	X Wire length	X Manual operator	XX Electrical connection
<b>JA</b> 110/50, 120/60 (2.9W)	<b>A</b> 18"	<b>1</b> Non-locking recessed	<b>KA</b> Square connector
<b>JB</b> 220/50, 240/60 (2.9W)	<b>B</b> 24"	<b>2</b> Locking recessed	<b>KD</b> Square connector with light
<b>JC</b> 24/60 (2.9W)	<b>J</b> Connector		<b>JB</b> Rectangular connector
<b>FB</b> 24 VDC (1.8W)			<b>JD</b> Rectangular connector with light
<b>DA</b> 24 VDC (5.4W)			<b>BA</b> Flying leads
<b>DF</b> 24 VDC (12.7W)			

\* Other options available, see page 309.

### OPTIONS

Spool type :

67A-**XX**-AAA-DM-Dxxx-xxx

- G** Single operator universal spool
- H** Double operator universal spool

Port configuration :

67A-XX-**AXA**-DM-Dxxx-xxx

- A** Standard pilot exhaust
- B** Pilot exhaust to main exhaust\*
- C** Pilot exhaust out adapter\*
- \* Must use DU pilot. Replace DM with DU

Mounting style :

67A-XX-**XAA**-DM-Dxxx-xxx

- G** O-Ring mount

Spool return :

67A-**XX**-AAA-DM-Dxxx-xxx

- 1** Standard return
- 2** Standard return with memory spring (for use with single operator only)

Pilot style :

67A-XX-AAA-**DM**-Dxxx-xxx

- M** Pilot exhaust muffled
- P** Pilot exhaust piped (#10-32)
- U** Pilot exhaust to main exhaust

33  
34  
36  
32  
37  
38  
52  
**67**

69  
44  
46  
42  
47  
48P

48  
400  
92

93  
ISO 01  
ISO 02  
ISO 1  
ISO 2  
ISO 3

**TECHNICAL DATA**

<b>Fluid :</b>	Compressed air, vacuum, inert gases
<b>Pressure range :</b>	Internal Pilot : 20 to 120 PSI External Pilot : Vacuum to 120 PSI
<b>Lubrication :</b>	Not required, if used select a medium aniline point lubricant (between 180°F and 210°F)
<b>Filtration :</b>	40 μ
<b>Temperature range :</b>	0°F to 120°F (-18°C to +50°C)
<b>Flow :</b>	3/4" : (14.5 C <sub>v</sub> ) – 1" : (20.0 C <sub>v</sub> )
<b>Coil :</b>	Class A continuous duty, #22 AWG x 18 lead wires
<b>Voltage range :</b>	-1.5% to +10% of nominal voltage
<b>Protection :</b>	Consult factory
<b>Power :</b>	~ Inrush : 7.6 VA    Holding : 4.8 VA = 12.7 to 1.0 W
<b>Response times : (with 5.4 W coil)</b>	Energize : 29 ms De-energize : 21 ms

Options :                    • BSPP threads

**DIMENSIONS**

Dimensions shown are metric (mm)

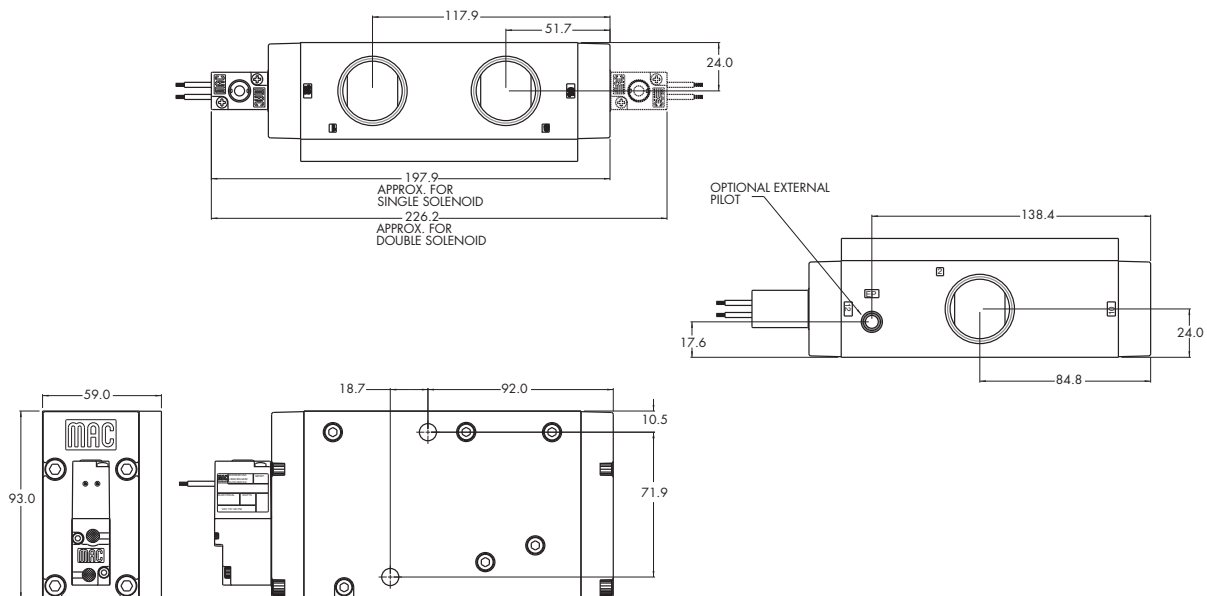

Individual mounting

Series

Inline

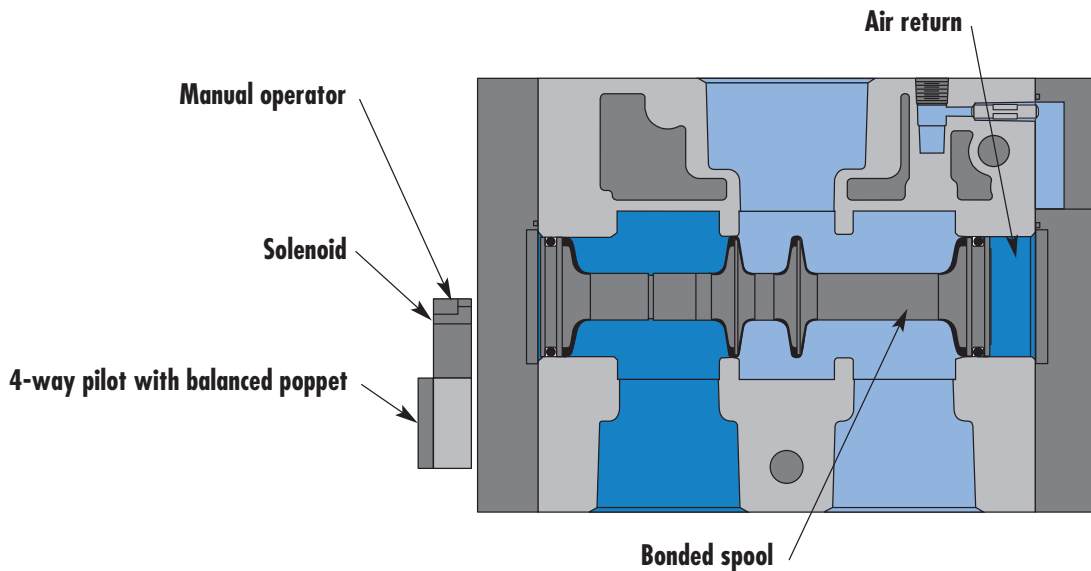

33  
34  
36  
32  
37  
38  
52  
67  
**69**  
44  
46  
42  
47  
48P  
48  
400  
92  
93  
ISO 01  
ISO 02  
ISO 1  
ISO 2  
ISO 3

**SERIES FEATURES**

- High force MACSOLENOID®.
- Optional low watt DC solenoids.
- Internal or external pilot.
- Normally open or normally closed function.
- Checked accumulator.
- May be plugged for 2-way operation.

Function	Port size	Flow (Max)	Individual mounting	Series
<b>3/2 NO-NC, 2/2 NO-NC</b>	<b>1 1/2" - 2" - 2 1/2"</b>	<b>60.0 C<sub>v</sub></b>	Inline	

### OPERATIONAL BENEFITS

1. The 4-way pilot develops maximum shifting force both ways.
2. Balanced spool, immune to variations of pressure, also provides high flow.
3. Short stroke with high flow.
4. Bonded spool with minimum friction, shifting in a glass-like finished bore.
5. Pilot with balanced poppet, high flow, short and consistent response times.
6. Wiping effect eliminates sticking and contamination.

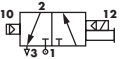
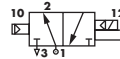

### HOW TO ORDER

Port size	Pilot air	Single Operator NC valve	Single Operator NO valve
			
<b>1 1/2"</b>	Internal	69A-A1-AAA-Jxxx-xxx	69A-C1-AAA-Jxxx-xxx
<b>2"</b>		69A-A1-BAA-Jxxx-xxx	69A-C1-BAA-Jxxx-xxx
<b>2 1/2"</b>		69A-A1-CAA-Jxxx-xxx	69A-C1-CAA-Jxxx-xxx
<b>1 1/2"</b>	External	69A-A1-AAB-Jxxx-xxx	69A-C1-AAB-Jxxx-xxx
<b>2"</b>		69A-A1-BAB-Jxxx-xxx	69A-C1-BAB-Jxxx-xxx
<b>2 1/2"</b>		69A-A1-CAB-Jxxx-xxx	69A-C1-CAB-Jxxx-xxx

### SOLENOID OPERATOR ▶

J **xxx-xxx**\* (-G) Add "G" for ground

XX Voltage	X Lead wire length	X Manual operator	XX Electrical connection*
<b>AA</b> 120 VAC (5,4W)	<b>0</b> No lead wire	<b>1</b> Non-locking	<b>BA</b> Flying leads
<b>DA</b> 24 VDC (5,4W)	<b>A</b> 18"	<b>2</b> Locking	<b>GA</b> MAC JAC Solenoid Plug-in
<b>DB</b> 12 VDC (5,4W)	<b>B</b> 24"		<b>GG</b> MAC JAC Solenoid Plug-in with rectifier
<b>DC</b> 24 VDC (2,4W)	<b>C</b> 36"		<b>JB</b> Rectangular connector
<b>DD</b> 12 VDC (2,4W)			<b>JD</b> Rectangular connector with light
			<b>KA</b> Mini square connector
			<b>KD</b> Mini square connector with light

\* Other options available, see page 317.  
 Note : use "0" No lead wire for "J", "K" and "L" type electrical connectors.  
 AC voltage requires connector with rectifier.

### OPTIONS

Pilot exhaust configuration:

69A-xx-xx **X**-Jxxx-xxx

- A** Standard pilot exhaust
- B** Pilot exhaust out main exhaust
- M** Manifold O'Ring Mount

33  
34  
36  
32  
37  
38  
52  
67  
69  
44  
46  
42  
47  
48P  
48  
400  
92  
93  
ISO 01  
ISO 02  
ISO 1  
ISO 2  
ISO 3



**TECHNICAL DATA**

<b>Fluid :</b>	Compressed air, vacuum, inert gases
<b>Pressure range :</b>	Internal Pilot : 20 to 120 PSI External Pilot : Vacuum to 120 PSI
<b>Pilot Pressure:</b>	20 to 120 PSI
<b>Lubrication :</b>	Not required, if used select a medium aniline point lubricant (between 180°F and 210°F)
<b>Filtration :</b>	40 μ
<b>Temperature range :</b>	0°F to 120°F (-18°C to +50°C)
<b>Flow :</b>	Cv 60.0
<b>Coil :</b>	Class A wire, #22 AWG x 18, continuous duty
<b>Voltage range :</b>	-1.5% to +10% of nominal voltage
<b>Power :</b>	5.4W – 2.4W – 1.8W

Options : • BSPP threads

**DIMENSIONS**

Dimensions shown are metric (mm)

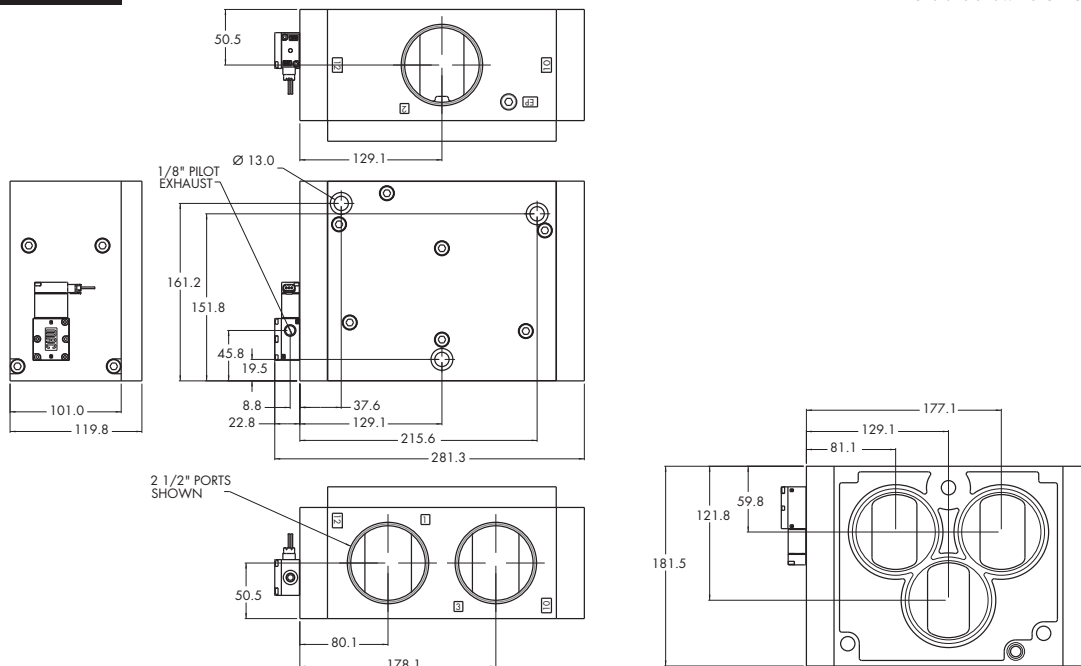

Individual mounting

Series

Inline
--------

33  
34  
36

Manual operator

32  
37

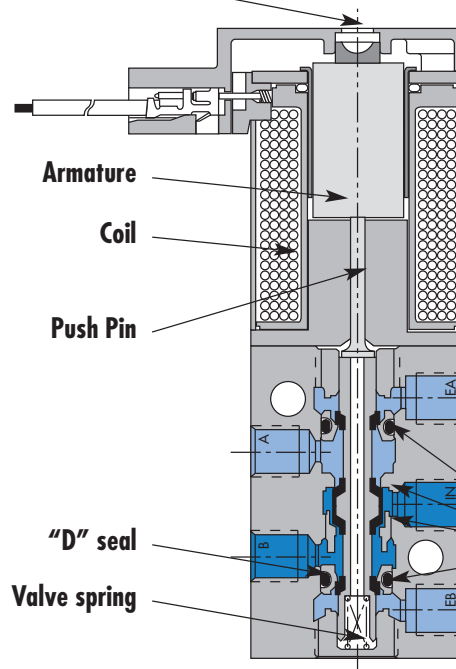

38  
52  
67  
69  
**44**  
46  
42  
47  
48P  
48

"D" seal

Valve spring

4 Balanced poppets

400  
92  
93

**SERIES FEATURES**

- High force MACSOLENOID®.
- 10mm direct operated.
- # 10-32 or M5 ports.
- Rated for lubricated or non-lubricated service.

ISO 01  
ISO 02  
ISO 1  
ISO 2  
ISO 3



# Direct solenoid and solenoid pilot operated valves

Function	Port size	Flow (Max)	Individual Mounting	Series
<b>5/2</b>	<b>M5, # 10-32</b>	<b>0.1 C<sub>v</sub></b>	Inline	

### OPERATIONAL BENEFITS

1. 10 mm valve, direct solenoid operated.
2. Balanced poppet, immune to variations of pressure.
3. Short stroke with high flow.
4. The patented solenoid develops high shifting forces.
5. Powerful return spring.
6. Flow is specifically adjusted on each valve.
7. Manual operator standard on all valves.



### HOW TO ORDER

#### SOLENOID OPERATOR

Port size	Universal valve	For use with external flow controls
<b>M5</b>	44C-ABA-G <b>XXX-XXX</b>	44C-BBA-G <b>XXX-XXX</b>
<b># 10-32</b>	44C-AAA-G <b>XXX-XXX</b>	44C-BAA-G <b>XXX-XXX</b>

#### SOLENOID OPERATOR >

G **XXX-XXX\***

XX Voltage	X Wire length	X Manual operator	XX Electrical connection
<b>AA</b> 120 VAC (2.5W)	<b>A</b> 18"	<b>1</b> Non-locking recessed	<b>BA</b> Flying leads
<b>DC</b> 24 VDC (1.8W)	<b>B</b> 24"	<b>2</b> Locking recessed	<b>BT</b> Flying leads with light
<b>DD</b> 24 VDC (2.5W)			<b>GA</b> MAC JAC Solenoid Plug-in
<b>DF</b> 24 VDC (4.0W)			<b>KA</b> Plug-in wire assembly
			<b>KC</b> Plug-in wire assembly with rectifier & light
			<b>KT</b> Plug-in wire assembly with light

\* Other options available, see page 311.  
Note : AC voltage requires connector with rectifier

33  
34  
36  
32  
37  
38  
52  
67  
69

44  
46  
42  
47  
48P  
48  
400  
92

93  
ISO 01  
ISO 02  
ISO 1  
ISO 2  
ISO 3

\* Other options available, see page 319.

**TECHNICAL DATA**

<b>Fluid :</b>	Compressed air, vacuum, inert gases
<b>Pressure range :</b>	Vacuum to 120 PSI
<b>Lubrication :</b>	Not required, if used select a medium aniline point lubricant (between 180°F and 210°F)
<b>Filtration :</b>	40 $\mu$
<b>Temperature range :</b>	0°F to 120°F (-18°C to +50°C)
<b>Flow :</b>	4 W : (0.10 C <sub>v</sub> ) – 2.5 W : (0.08 C <sub>v</sub> ) – 1.8 W : (0.06 C <sub>v</sub> ) – 1.0W : (0.05 C <sub>v</sub> )
<b>Coil :</b>	Class A wire (#22 AWG x 18), continuous duty
<b>Voltage range :</b>	-1.5% to +10% of nominal voltage
<b>Power :</b>	4 W – 2.5 W – 1.8 W – 1.0 W
<b>Response times : (with 4 W coil)</b>	Energize : 3.4 ms De-energize : 1.5 ms

Note : 

- Valve and coil are not interchangeable.

**DIMENSIONS**

Dimensions shown are metric (mm)

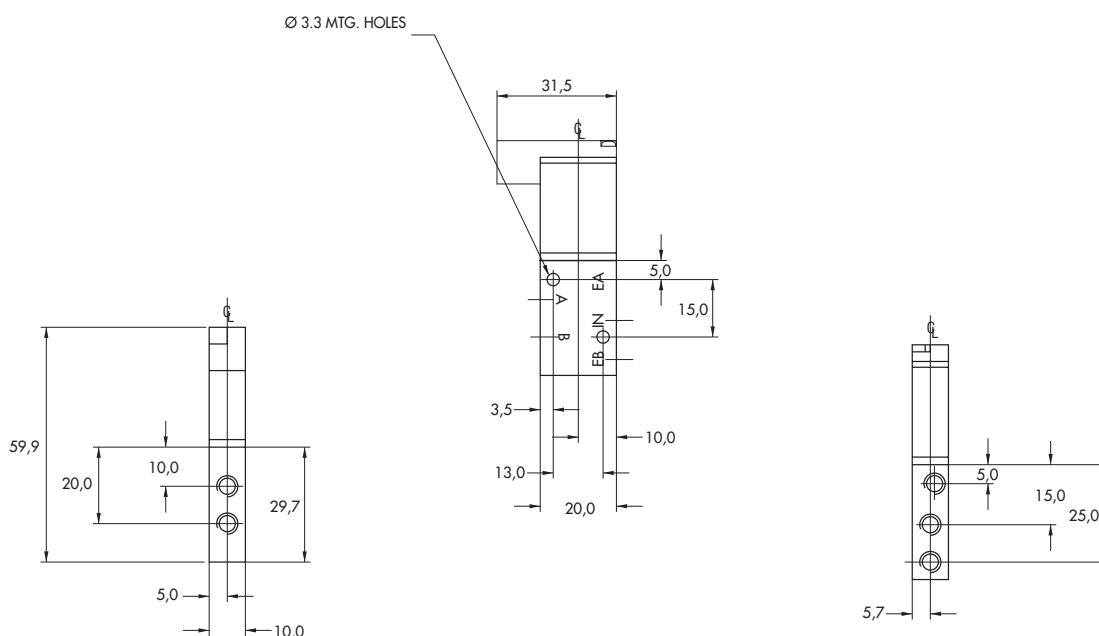

# Direct solenoid and solenoid pilot operated valves

## Individual mounting

Inline	
--------	--

Series

## Manifold mounting

Stacking	Manifold base "plug-in"	Manifold base "plug-in" with pressure regulators	Manifold base "plug-in" with flow controls	Manifold base "plug-in" with PR & FC
----------	-------------------------	--	--	--------------------------------------

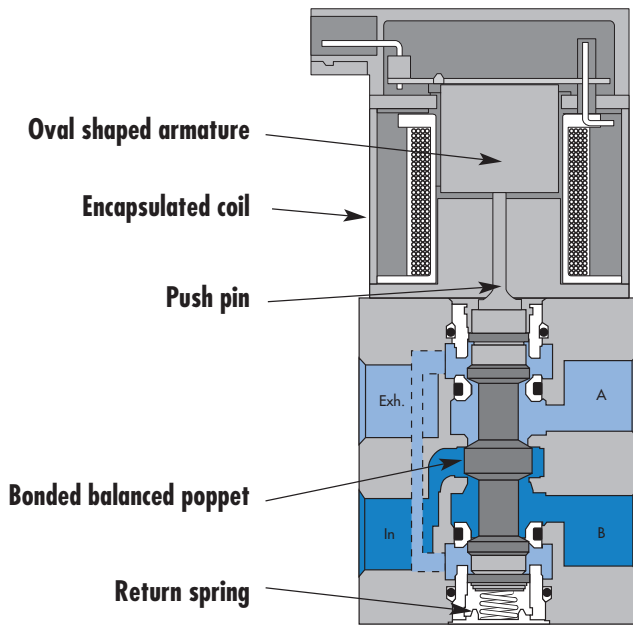

33

34

36

32

37

38

52

67

69

44

46

42

47

48P

48

400

92

## SERIES FEATURES

- Patented high force MACSOLENOID® for fastest possible response times.
- Bonded balanced poppet for high flow, precise repeatability, and consistent operation.
- Balanced poppet permits versatility in function — may be used as 3-way or 2-way normally open or normally closed and may be used for vacuum, diverter, or selector applications.
- Extremely high cycle rate capability.
- Use on lube or non-lube service.
- Manual overrides as standard.
- Various solenoid enclosures and plug-in connectors.
- Optional surge suppression available.
- Low wattage DC solenoids — down to 1.3 watts.
- Rectified AC voltage.

93

ISO 01

ISO 02

ISO 1

ISO 2

ISO 3



# Direct solenoid and solenoid pilot operated valves

Function	Port size	Flow (Max)	Individual mounting	Series
<b>4/2</b>	<b>1/8" - # 10-32</b>	<b>0.3 C<sub>v</sub></b>	Inline	

### OPERATIONAL BENEFITS

- Balanced poppet, immune to variations of pressure.
- Patented solenoid develops high shifting forces.
- Short stroke with high flow.
- Higher forces result in lower wattages for given flow.
- Powerful return spring.



### HOW TO ORDER

Port size	Single Operator		Double Operator	
	Without flow controls	With flow controls	Without flow controls	With flow controls
<b>1/8" NPTF</b>	46A-AA1-J <b>xxx-xxx</b>	46A-AA2-J <b>xxx-xxx</b>	46A-GA1-J <b>xxx-xxx</b>	46A-GA2-J <b>xxx-xxx</b>
<b># 10-32</b>	46A-AB1-J <b>xxx-xxx</b>	46A-AB2-J <b>xxx-xxx</b>	46A-GB1-J <b>xxx-xxx</b>	46A-GB2-J <b>xxx-xxx</b>

### SOLENOID OPERATOR >

**J xxx-xxx\*** (-G) Add "G" for ground

XX Voltage	X Wire length	X Manual operator	XX Electrical connection
<b>Single &amp; double solenoid</b>	<b>**O</b> No leads	<b>1</b> Non-locking recessed	<b>BA</b> Flying leads
<b>AA</b> 120 VAC (5.4W)	<b>A</b> 18"	<b>2</b> Locking recessed	<b>GA</b> MAC JAC solenoid plug-in
<b>DA</b> 24 VDC (5.4W)	<b>B</b> 24"		<b>GG</b> MAC JAC solenoid plug-in with rectifier
<b>DB</b> 12 VDC (5.4W)	<b>C</b> 36"		<b>JB</b> Rectangular connector
<b>Single solenoid only</b>			<b>JD</b> Rectangular connector with light
<b>DC</b> 24 VDC (2.4W)			<b>KA</b> Mini square connector
<b>DD</b> 12 VDC (2.4W)			<b>KD</b> Mini square connector with light

\* Other options available, see page 317.

\*\* Use with rectangular and mini connectors

Note : - AC voltage requires connector with rectifier.

- With the MAC JAC, washdown capability is possible. Consult factory for washdown modification number.  
Double solenoid requires minimum 5.4 watts.

### OPTIONS

**46A-AA1-Jxxx-xxx**

**G** Use with O ring mount (body option 'D' & 'H')

- A** Single operator - 4 port body with side ports
- C** Single operator - 4 port body with bottom ports (No side ports - M5 or #10-32 ONLY)
- D** Single operator - Bottom O ring mount - All ports (No side ports)
- F** Single operator - Bottom O ring mount - Cylinder ports only - Side inlet & exhaust
- G** Double operator - 4 Port body - With side ports
- H** Double operator - Bottom O ring mount - All ports (No side ports)

Examples : 46A-DG1-Jxxx-xxx (Bottom O ring mount - all ports)  
46A-CB1-Jxxx-xxx (4 port body with bottom ports - no side ports)

33  
34  
36  
32  
37  
38  
52  
67  
69  
44  
46  
42  
47  
48P  
48  
400  
92  
93  
ISO 01  
ISO 02  
ISO 1  
ISO 2  
ISO 3

**TECHNICAL DATA**

<b>Fluid :</b>	Compressed air, vacuum, inert gases
<b>Pressure range :</b>	Vacuum to 120 PSI
<b>Lubrication :</b>	Not required, if used select a medium aniline point lubricant (between 180°F and 210°F)
<b>Filtration :</b>	40 μ
<b>Temperature range :</b>	0°F to 120°F (-18°C to +50°C)
<b>Orifice :</b>	3,3 mm
<b>Flow :</b>	1.8W : (0.20 C <sub>v</sub> ) – 2.4W : (0.20 C <sub>v</sub> ) – 5.4W : (0.30 C <sub>v</sub> )
<b>Coil :</b>	Class A wire (#22 AWG x 18), continuous duty
<b>Voltage range :</b>	-15% to +10% of nominal voltage
<b>Protection :</b>	Consult factory
<b>Power :</b>	5.4W – 2.4W – 1.8W

Options : • BSPP threads

**DIMENSIONS**

Dimensions shown are metric (mm)

**Single solenoid**

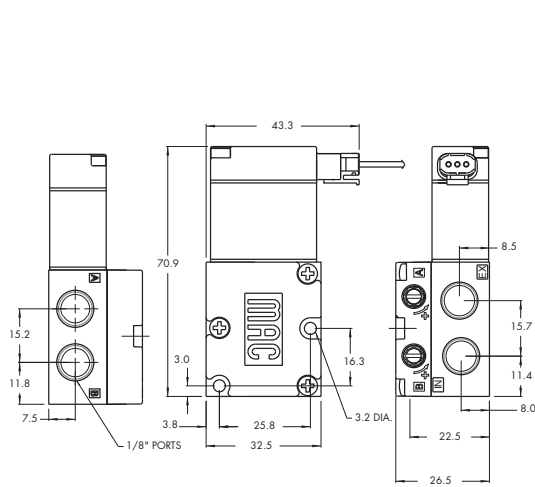

**Double solenoid**

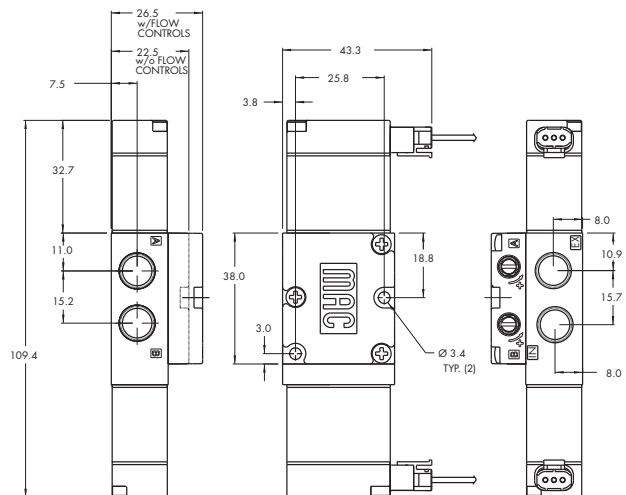



# Direct solenoid and solenoid pilot operated valves

Function	Port size	Flow (Max)	Manifold Mounting	Series
<b>4/2</b>	<b>1/8" - # 10-32</b>	<b>0.3 C<sub>v</sub></b>	Stacking	

### OPERATIONAL BENEFITS

1. Balanced poppet, immune to variations of pressure.
2. Patented solenoid develops high shifting forces.
3. Short stroke with high flow.
4. Higher forces result in lower wattages for given flow.
5. Powerful return spring.



### HOW TO ORDER

Port size	Without flow controls	With flow controls
<b>1/8" NPTF</b>	46A-SA1-J XXX-XXX	46A-SA2-J XXX-XXX
<b># 10-32</b>	46A-SB1-J XXX-XXX	46A-SB2-J XXX-XXX

### SOLENOID OPERATOR >

J **XXX-XXX**\* (-G) Add "G" for ground

XX	Voltage	X	Wire length	X	Manual operator	XX	Electrical connection
AA	120 VAC (5.4W)	A	18"	1	Non-locking recessed	BA	Flying leads
DA	24 VDC (5.4W)	B	24"	2	Locking recessed	GA	MAC JAC solenoid plug-in
DB	12 VDC (5.4W)	C	36"			GB	MAC JAC solenoid plug-in with diode
DC	24 VDC (2.4W)					GG	MAC JAC solenoid plug-in with rectifier
DD	12 VDC (2.4W)						

\* Other options available, see page 317.

Note : - AC voltage requires connector with rectifier.

- With the MAC JAC, washdown capability is possible. Consult factory for washdown modification number.

End plate kit required (port size 1/4") : M-46001-01.

33  
34  
36  
32  
37  
38  
52  
67  
69  
44  
46  
42  
47  
48P  
48  
400  
92  
93  
ISO 01  
ISO 02  
ISO 1  
ISO 2  
ISO 3



**TECHNICAL DATA**

<b>Fluid :</b>	Compressed air, vacuum, inert gases
<b>Pressure range :</b>	Vacuum to 120 PSI
<b>Lubrication :</b>	Not required, if used select a medium aniline point lubricant (between 180°F and 210°F)
<b>Filtration :</b>	40 μ
<b>Temperature range :</b>	0°F to 120°F (-18°C to +50°C)
<b>Flow :</b>	1.8W : (0.20 C <sub>v</sub> ) – 2.4W : (0.20 C <sub>v</sub> ) – 5.4W : (0.30 C <sub>v</sub> )
<b>Coil :</b>	Class A wire (#22 AWG x 18), continuous duty
<b>Voltage range :</b>	-1.5% to +10% of nominal voltage
<b>Protection :</b>	Consult factory
<b>Power :</b>	5.4W – 2.4W – 1.8W
<b>Response times : (with 5.4 W coil)</b>	Energize : 7.20 ms De-energize : 4.20ms

- Options : • BSPP threads
- Spare parts : • Inlet isolator : 28494 • Exhaust isolator : 28493 • Tie rod (x2) : 79411

**DIMENSIONS**

Dimensions shown are metric (mm)

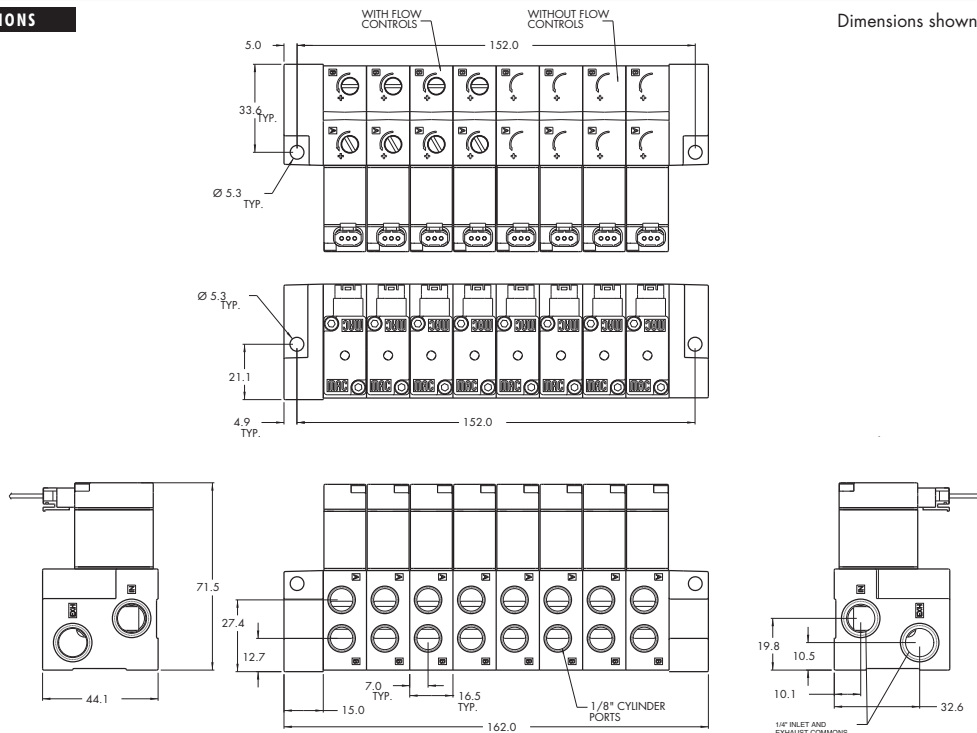



# Direct solenoid and solenoid pilot operated valves

Function	Port size	Flow [Max]	Manifold mounting	Series
<b>4/2</b>	<b>1/8" - 5/32 O.D. Pressed-in tube receptacles</b>	<b>0.3 C<sub>v</sub></b>	Manifold base "plug-in"	

### OPERATIONAL BENEFITS

- Balanced poppet, immune to variations of pressure.
- Patented solenoid develops high shifting forces.
- Short stroke with high flow.
- Higher forces result in lower wattages for given flow.
- Powerful return spring.



33  
34  
36  
32  
37  
38  
52  
67  
69  
44  
46

### HOW TO ORDER

Port size	Single solenoid	Double solenoid
<b>Valve less base</b>	46A-L00-00-J <b>XX</b> P- <b>XXX</b>	46A-N00-00-J <b>XX</b> P- <b>XXX</b>
<b>1/8" NPTF</b>	46A-LSA-AC-J <b>XX</b> P- <b>XXX</b>	46A-NSA-BL-J <b>XX</b> P- <b>XXX</b>
<b>5/32 O.D. Pressed-in tube receptacles</b>	46A-LSF-AC-J <b>XX</b> P- <b>XXX</b>	46A-NSF-BL-J <b>XX</b> P- <b>XXX</b>

42  
47  
48P

### SOLENOID OPERATOR >

J **XX** P-**XXX**\* (-G) Add "G" for ground

<b>XX</b> Voltage	<b>X</b> Manual operator	<b>XX</b> Electrical connection
<b>Single &amp; double solenoid</b>	<b>1</b> Non-locking	<b>FA</b> Base plug-in
<b>AA</b> 120 VAC (5,4W)	<b>2</b> Locking	<b>FB</b> Base plug-in with diode
<b>AC</b> 24 VAC (5,4W)		<b>FG</b> Base plug-in with rectifier
<b>DA</b> 24 VDC (5,4W)		
<b>DB</b> 12 VDC (5,4W)		
<b>Single solenoid only</b>		
<b>DC</b> 24 VDC (2,4W)		
<b>DD</b> 12 VDC (2,4W)		

48  
400

\* Other options available, see page 317.  
Note : AC voltage requires connector with rectifier. Double solenoid requires minimum 5.4 watts.

### OPTIONS

46A-LSB-AC-J**XX**P-**XXX**

- C** Single solenoid - Side cylinder ports
- L** Single & double solenoid - Bottom cylinder ports
- O** Base only - no valve
- L** Single solenoid - Base mount body
- M** Single solenoid - Base mount body with gage port
- N** Double solenoid - Base mount body
- P** Double solenoid - Base mount body with gage port

92  
93  
ISO 01  
ISO 02  
ISO 1  
ISO 2  
ISO 3

Example : base only : 46A-OSA-AC.  
End plate kit required (port size 1/4") : M-46003-01.

**TECHNICAL DATA**

<b>Fluid :</b>	Compressed air, vacuum, inert gases
<b>Pressure range :</b>	Vacuum to 120 PSI
<b>Lubrication :</b>	Not required, if used select a medium aniline point lubricant (between 180°F and 210°F)
<b>Filtration :</b>	40 µ
<b>Temperature range :</b>	0°F to 120°F (-18°C to +50°C)
<b>Orifice</b>	3.3 mm
<b>Flow :</b>	1.8W : (0.20 C <sub>v</sub> ) – 2.4W : (0.20 C <sub>v</sub> ) – 5.4W : (0.30 C <sub>v</sub> )
<b>Coil :</b>	Epoxy encapsulated – Class A wires – 100% ED
<b>Voltage range :</b>	-15% to +10% of nominal voltage
<b>Protection :</b>	IP54 (electrical connection)
<b>Power :</b>	5.4W – 2.4W – 1.8W
<b>Response times :</b>	Energize : 7.20 ms De-energize : 4.20ms

- Options :
- BSPP threads
- Spare parts :
- Inlet isolator : 28501 • Exhaust isolator : 28502 • Valve cover plate : M-46002
  - Tie rod (x2) : 79443

**DIMENSIONS**

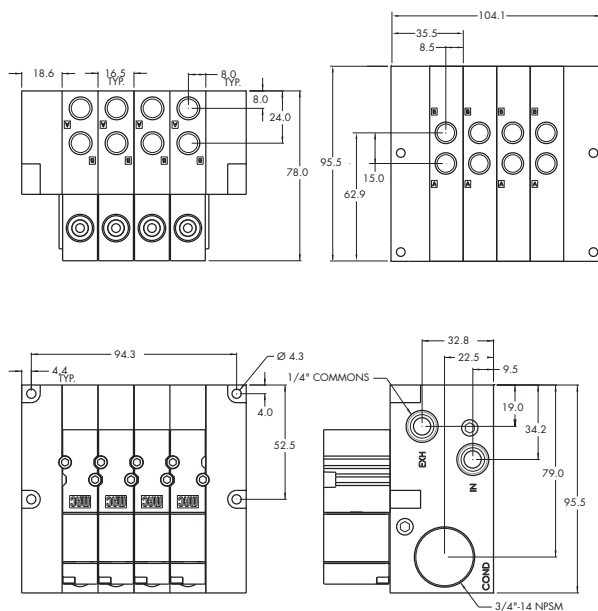

Dimensions shown are metric (mm)

**Double solenoid**

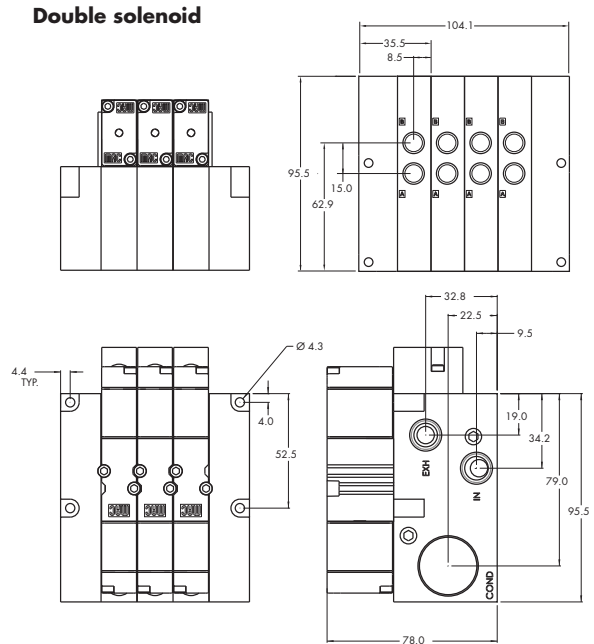

Function	Port size	Flow [Max]	Manifold mounting	Series
4/2	1/8" - 5/32 O.D. Pressed-in tube receptacles	0.3 C <sub>v</sub>	Manifold base "plug-in" with pressure regulators	

**OPERATIONAL BENEFITS**

- Balanced poppet, immune to variations of pressure.
- Patented solenoid develops high shifting forces.
- Short stroke with high flow.
- Higher forces result in lower wattages for given flow.
- Powerful return spring.



**HOW TO ORDER**

Port size (Bottom ports only)	Model number
Valve less base	46A-L00-00-J xxP-xxx
1/8" NPTF	46A-LSA-AJ-J xxP-xxx
5/32 O.D. Pressed-in tube receptacles	46A-LSF-AJ-J xxP-xxx

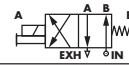

**SOLENOID OPERATOR >**

J **XX P-XXX\*** (-G) Add "G" for ground

XX Voltage	X Manual operator	XX Electrical connection
AA 120 VAC (5.4W)	1 Non-locking recessed	FA Base plug-in
DA 24 VDC (5.4W)	2 Locking recessed	FB Base plug-in with diode
DB 12 VDC (5.4W)		FG Base plug-in with rectifier
DC 24 VDC (2.4W)		

\* Other options available, see page 317.  
Note : AC voltage requires connector with rectifier.

**OPTIONS**

46A-LSA-AJ-JxxP-xxx

- J Regulator with adjusting knob
- E Regulator with slotted stem
- G Regulator with slotted stem with locknut
- O Base only – no valve
- L Base mount body
- M Base mount body with gage port

Example : base only with regulator : 46A-0SA-AJ.  
End plate kit required (port size 1/4") : M-46003-01.

- 33
- 34
- 36
- 32
- 37
- 38
- 52
- 67
- 69
- 44
- 46
- 42
- 47
- 48P
- 48
- 400
- 92
- 93
- ISO 01
- ISO 02
- ISO 1
- ISO 2
- ISO 3

**TECHNICAL DATA**

<b>Fluid :</b>	Compressed air, vacuum, inert gases
<b>Pressure range :</b>	Vacuum to 120 PSI
<b>Lubrication :</b>	Not required, if used select a medium aniline point lubricant (between 180°F and 210°F)
<b>Filtration :</b>	40 μ
<b>Temperature range :</b>	0°F to 120°F (-18°C to +50°C)
<b>Flow :</b>	1.8W : (0.20 C <sub>v</sub> ) – 2.4W : (0.20 C <sub>v</sub> ) – 5.4W : (0.30 C <sub>v</sub> )
<b>Coil :</b>	Class A continuous duty, #22 AWG x 12 base leads
<b>Voltage range :</b>	-1.5% to +10% of nominal voltage
<b>Protection :</b>	Consult factory
<b>Power :</b>	5.4W – 2.4W – 1.8W
<b>Response times : (with 5.4 W coil)</b>	Energize : 7.20 ms De-energize : 4.20ms

- Options :  
Spare parts :
- BSPP threads
  - Inlet isolator : 28501 • Exhaust isolator : 28502 • Valve cover plate : M-46002 • Tie rod (x2) : 79443
  - Replacement regulators : PR46A-OAAA (slotted stem)  
PR46A-OBAA (adjusting knob)  
PR46A-OCAA (slotted stem with locknut)
- Regulating range options : • PR46A-xxx**A**
- A** 0 to 120 PSI
  - B** 0 to 80 PSI
  - C** 0 to 30 PSI

**DIMENSIONS**

Dimensions shown are metric (mm)

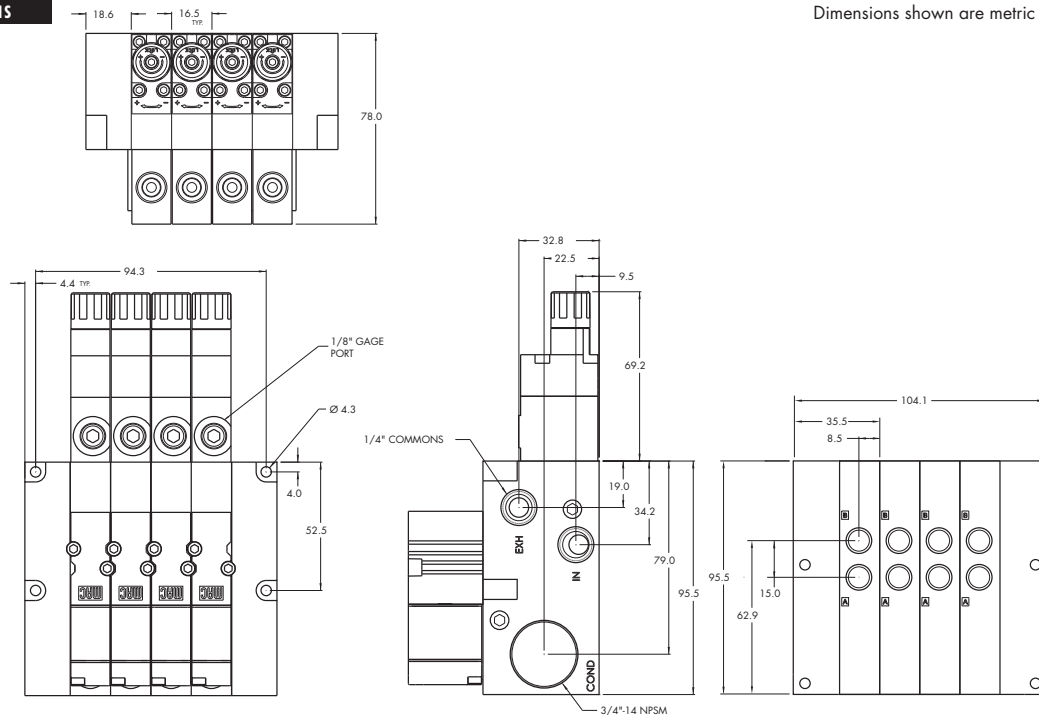



# Direct solenoid and solenoid pilot operated valves

Function	Port size	Flow [Max]	Manifold mounting	Series
<b>4/2</b>	<b>1/8" - 5/32 O.D. Pressed-in tube receptacles</b>	<b>0.3 C<sub>v</sub></b>	Manifold base "plug-in" with flow controls	

### OPERATIONAL BENEFITS

1. Balanced poppet, immune to variations of pressure.
2. Patented solenoid develops high shifting forces.
3. Short stroke with high flow.
4. Higher forces result in lower wattages for given flow.
5. Powerful return spring.

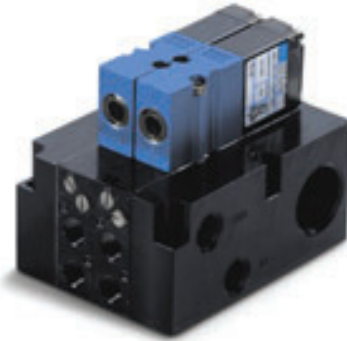

33  
34  
36  
32  
37  
38  
52  
67  
69  
44

### HOW TO ORDER

Port size	Model number
<b>Valve less base</b>	46A-L00-00-J <b>xxP-xxx</b>
<b>1/8" NPTF</b>	46A-LSA-AD-J <b>xxP-xxx</b>
<b>5/32 O.D. Pressed-in tube receptacles</b>	46A-LSF-AD-J <b>xxP-xxx</b>



46  
42

### SOLENOID OPERATOR >

J **XX P-XXX**\* (-G) Add "G" for ground

XX Voltage	X Manual operator	XX Electrical connection
<b>AA</b> 120 VAC (5.4W)	<b>1</b> Non-locking recessed	<b>FA</b> Base plug-in
<b>DA</b> 24 VDC (5.4W)	<b>2</b> Locking recessed	<b>FB</b> Base plug-in with diode
<b>DB</b> 12 VDC (5.4W)		<b>FG</b> Base plug-in with rectifier
<b>DC</b> 24 VDC (2.4W)		

47  
48P  
48

\* Other options available, see page 317.  
Note : AC voltage requires connector with rectifier.

### OPTIONS

46A-LSA-AD-J**xxP-xxx**

- D** Side cylinder ports
- M** Bottom cylinder ports
- O** Base only – no valve
- L** Base mount body
- M** Base mount body with gage port

Example : base only with flow controls: 46A-0SA-AD.  
End plate kit required (port size 1/4") : M-46003-01.

400  
92  
93  
ISO 01  
ISO 02  
ISO 1  
ISO 2  
ISO 3

**TECHNICAL DATA**

<b>Fluid :</b>	Compressed air, vacuum, inert gases
<b>Pressure range :</b>	Vacuum to 120 PSI
<b>Lubrication :</b>	Not required, if used select a medium aniline point lubricant (between 180°F and 210°F)
<b>Filtration :</b>	40 μ
<b>Temperature range :</b>	0°F to 120°F (-18°C to +50°C)
<b>Flow :</b>	1.8W : (0.20 C <sub>v</sub> ) – 2.4W : (0.20 C <sub>v</sub> ) – 5.4W : (0.30 C <sub>v</sub> )
<b>Coil :</b>	Class A continuous duty, #22 AWG x 12 base leads
<b>Voltage range :</b>	-1.5% to +10% of nominal voltage
<b>Protection :</b>	Consult factory
<b>Power :</b>	5.4W – 2.4W – 1.8W
<b>Response times :</b>	Energize : 7.20 ms De-energize : 4.20ms

- Options :
- BSPP threads
- Spare parts :
- Inlet isolator : 28501 • Exhaust isolator : 28502 • Valve cover plate : M-46002
  - Tie rod (x2) : 79443

**DIMENSIONS**

Dimensions shown are metric (mm)

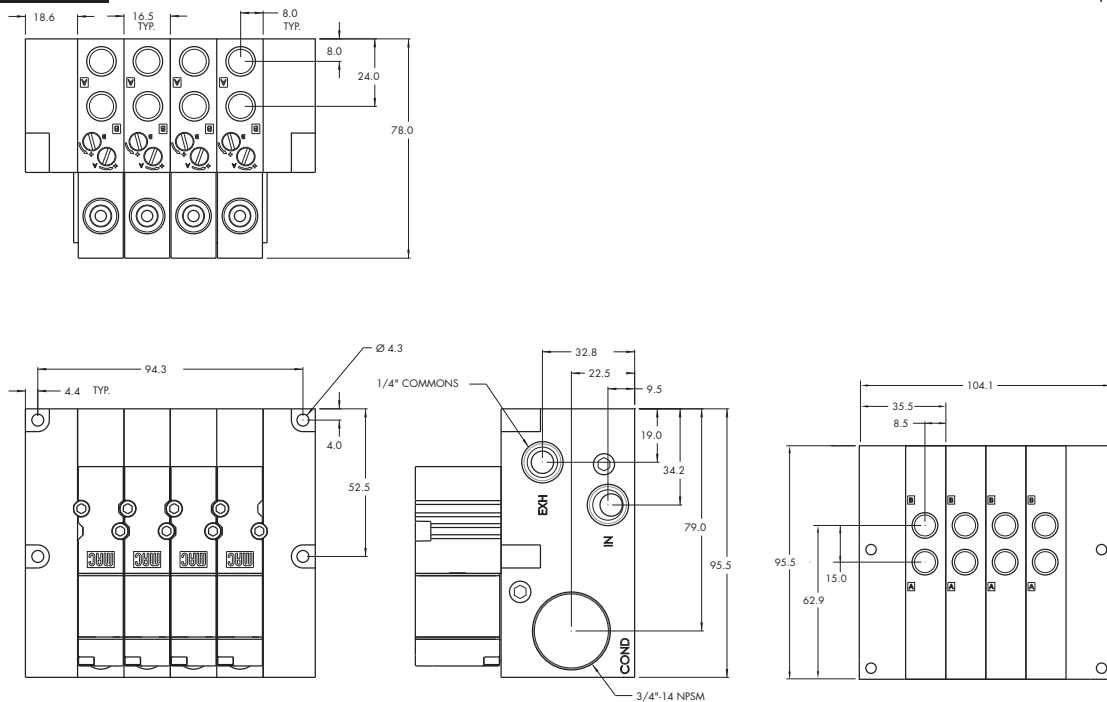



# Direct solenoid and solenoid pilot operated valves

Function	Port size	Flow [Max]	Manifold mounting	Series
<b>4/2</b>	<b>1/8" - 5/32 O.D. Pressed-in tube receptacles</b>	<b>0.3 C<sub>v</sub></b>	Manifold base "plug-in" with PR & FC	

### OPERATIONAL BENEFITS

1. Balanced poppet, immune to variations of pressure.
2. Patented solenoid develops high shifting forces.
3. Short stroke with high flow.
4. Higher forces result in lower wattages for given flow.
5. Powerful return spring.



33  
34  
36  
32  
37  
38  
52  
67  
69  
44

### HOW TO ORDER

Port size (Bottom ports only)	Model number
Valve less base	46A-L00-00-J <b>xxP-xxx</b>
1/8" NPTF	46A-LSA-AK-J <b>xxP-xxx</b>
5/32 O.D. Pressed-in tube receptacles	46A-LSF-AK-J <b>xxP-xxx</b>



46

### SOLENOID OPERATOR >

J **XX P-XXX\*** (-G) Add "G" for ground

XX Voltage	X Manual operator	XX Electrical connection
<b>AA</b> 120 VAC (5.4W)	<b>1</b> Non-locking recessed	<b>FA</b> Base plug-in
<b>DA</b> 24 VDC (5.4W)	<b>2</b> Locking recessed	<b>FB</b> Base plug-in with diode
<b>DB</b> 12 VDC (5.4W)		<b>FG</b> Base plug-in with rectifier
<b>DC</b> 24 VDC (2.4W)		

47  
48P

\* Other options available, see page 317.  
Note : AC voltage requires connector with rectifier.

### OPTIONS

46A-LSA-AK-J <b>xxP-xxx</b>	Options
<b>K</b>	Regulator with adjusting knob & flow controls
<b>F</b>	Regulator with slotted stem & flow controls
<b>H</b>	Regulator with slotted stem with locknut & flow controls
<b>O</b>	Base only – no valve
<b>L</b>	Base mount body
<b>M</b>	Base mount body with gage port

Example : base only with regulator : 46A-OSA-AK.  
End plate kit required (port size 1/4") : M-46003-01.

48

400

92

93

ISO 01

ISO 02

ISO 1

ISO 2

ISO 3



**TECHNICAL DATA**

<b>Fluid :</b>	Compressed air, vacuum, inert gases
<b>Pressure range :</b>	Vacuum to 120 PSI
<b>Lubrication :</b>	Not required, if used select a medium aniline point lubricant (between 180°F and 210°F)
<b>Filtration :</b>	40 µ
<b>Temperature range :</b>	0°F to 120°F (-18°C to +50°C)
<b>Flow :</b>	1.8W : (0.20 C <sub>v</sub> ) – 2.4W : (0.20 C <sub>v</sub> ) – 5.4W : (0.30 C <sub>v</sub> )
<b>Coil :</b>	Class A continuous duty, #22 AWG x 12 base leads
<b>Voltage range :</b>	-1.5% to +10% of nominal voltage
<b>Protection :</b>	Consult factory
<b>Power :</b>	5.4W – 2.4W – 1.8W
<b>Response times :</b>	Energize : 7.20 ms De-energize : 4.20ms

- Options :  
Spare parts :
- BSPP threads
  - Inlet isolator : 28501
  - Exhaust isolator : 28502
  - Valve cover plate : M-46002
  - Tie rod (x2) : 79443
  - Replacement regulators : PR46A-OAAA (slotted stem)  
PR46A-OBAA (adjusting knob)  
PR46A-OCAA (slotted stem with locknut)
- Regulating range options : • PR46A-xxx**A**
- A** 0 to 120 PSI
  - B** 0 to 80 PSI
  - C** 0 to 30 PSI

**DIMENSIONS**

Dimensions shown are metric (mm)

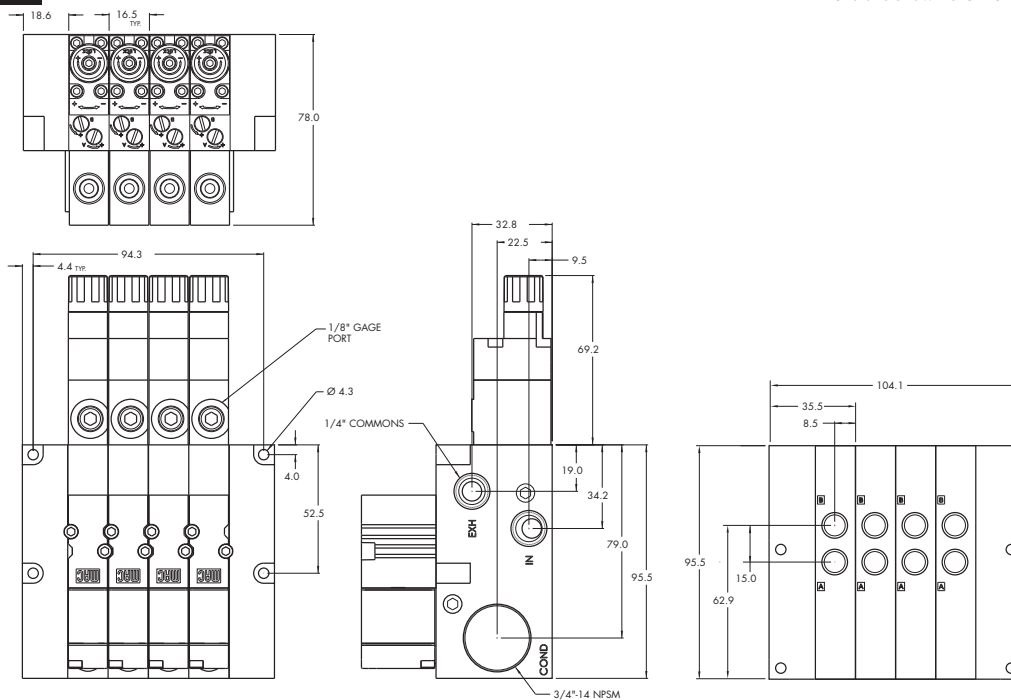

Individual mounting

Sub-base non "plug-in"	Sub-base "plug-in"	Sub-base/manifold base non "plug-in" with latching solenoid	Sub-base/manifold base "plug-in" with latching solenoid
------------------------	--------------------	---	---

Series

Manifold mounting

Manifold base non "plug-in"	Manifold base "plug-in"	Sub-base/manifold base non "plug-in" with latching solenoid	Sub-base/manifold base "plug-in" with latching solenoid
-----------------------------	-------------------------	---	---

33

34

36

32

37

38

52

67

69

44

46

42

47

48P

48

400

92

93

ISO 01

ISO 02

ISO 1

ISO 2

ISO 3

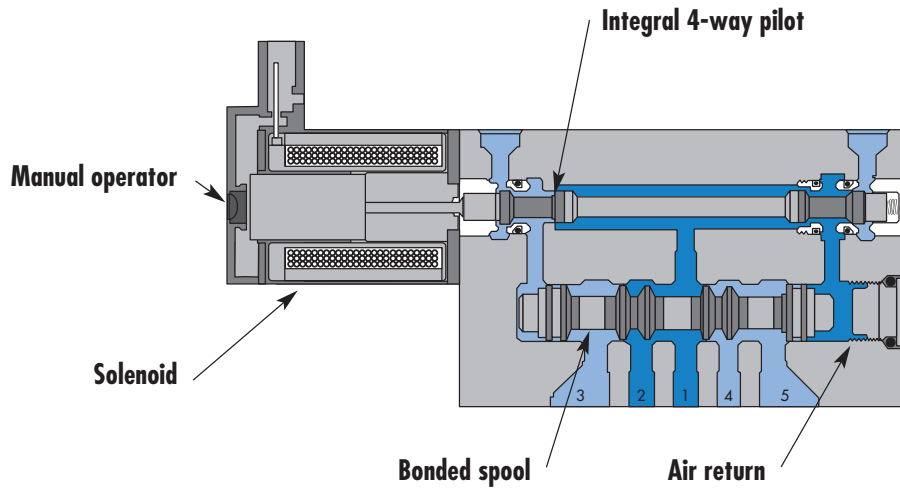

**SERIES FEATURES**

- High force MACSOLENOID®.
- Integral 4-way pilot design.
- Single or dual pressure.
- Internal or external pilot.
- Single or double solenoid.
- 2 or 3 position.
- Rectified AC voltage.
- Latching solenoid technology.



# Direct solenoid and solenoid pilot operated valves

Function	Port size	Flow (Max)	Individual mounting	Series
<b>5/2, 5/3</b>	<b># 10-32 - 1/4" O.D. tube receptacle</b>	<b>0.4 C<sub>v</sub></b>	Sub-base non "plug-in"	

### OPERATIONAL BENEFITS

1. 4-way valve with 4-way integral pilot.
2. 10 mm valve (stacks on 10.5 mm centers).
3. High flow (up to 0.4 C<sub>v</sub>).
4. Fast repeatable response times.
5. Maximum shifting forces in both directions.
6. Long life.



33  
34  
36  
32  
37  
38  
52  
67

### HOW TO ORDER

#### SINGLE PRESSURE MODELS (VALVE WITH BASE CODED FOR SIDE PORTS)

Port size	Pilot air	5/2 Single solenoid	5/2 Double solenoid	5/3 Closed center	5/3 Open center
<b>Valve less base</b>	Internal	42B-AMA-000-Gxxx-xxx	42B-BMA-000-Gxxx-xxx	42B-EMA-000-Gxxx-xxx	42B-FMA-000-Gxxx-xxx
	External	42B-AMD-000-Gxxx-xxx	42B-BMD-000-Gxxx-xxx	42B-EMD-000-Gxxx-xxx	42B-FMD-000-Gxxx-xxx
<b># 10-32</b>	Internal	42B-AMA-AAL-Gxxx-xxx	42B-BMA-AAL-Gxxx-xxx	42B-EMA-AAL-Gxxx-xxx	42B-FMA-AAL-Gxxx-xxx
	External	42B-AMD-AAM-Gxxx-xxx	42B-BMD-AAM-Gxxx-xxx	42B-EMD-AAM-Gxxx-xxx	42B-FMD-AAM-Gxxx-xxx
<b>1/4" O.D. tube receptacles</b>	Internal	42B-AMA-EAL-Gxxx-xxx	42B-BMA-EAL-Gxxx-xxx	42B-EMA-EAL-Gxxx-xxx	42B-FMA-EAL-Gxxx-xxx
	External	42B-AMD-EAM-Gxxx-xxx	42B-BMD-EAM-Gxxx-xxx	42B-EMD-EAM-Gxxx-xxx	42B-FMD-EAM-Gxxx-xxx

69  
44  
46  
42  
47  
48P

#### DUAL PRESSURE MODELS (VALVE WITH BASE CODED FOR SIDE PORTS)

Port size	Pilot air	5/2 Single solenoid	5/2 Double solenoid	5/3 Pressure center
<b>Valve less base</b>	Internal	Supply #3 port	42B-CMB-000-Gxxx-xxx	42B-DMB-000-Gxxx-xxx
	Internal	Supply #5 port	42B-CMC-000-Gxxx-xxx	42B-DMC-000-Gxxx-xxx
	External		42B-CMD-000-Gxxx-xxx	42B-DMD-000-Gxxx-xxx
<b># 10-32</b>	Internal	Supply #3 port	42B-CMB-AAL-Gxxx-xxx	42B-DMB-AAL-Gxxx-xxx
	Internal	Supply #5 port	42B-CMC-AAL-Gxxx-xxx	42B-DMC-AAL-Gxxx-xxx
	External		42B-CMD-AAM-Gxxx-xxx	42B-DMD-AAM-Gxxx-xxx
<b>1/4" O.D. tube receptacles</b>	Internal	Supply #3 port	42B-CMB-EAL-Gxxx-xxx	42B-DMB-EAL-Gxxx-xxx
	Internal	Supply #5 port	42B-CMC-EAL-Gxxx-xxx	42B-DMC-EAL-Gxxx-xxx
	External		42B-CMD-EAM-Gxxx-xxx	42B-DMD-EAM-Gxxx-xxx

48  
400  
92  
93  
ISO 01  
ISO 02  
ISO 1  
ISO 2  
ISO 3

#### STANDARD SOLENOID OPERATOR >

XX	Voltage	X	Wire length	X	Manual operator	XX	Electrical connection
AA	120 VAC (2.5W)	A	18"	1	Non-locking recessed	BA	Flying leads
DC	24 VDC (1.8W)	B	24"	2	Locking recessed	BT	Flying leads with light
DD	24 VDC (2.5W)					GA	MAC JAC solenoid Plug-in
DF	24 VDC (4.0W)	C	36"			KA	Plug-in wire Assy.
						KT	Plug-in wire Assy. with light
						KD	Plug-in wire Assy. with rectifier & light & ground

Note : AC voltage requires connector with rectifier.  
\* Other options available, see page 311.  
Latching solenoid available for 5/2 valves.

Other options available for the 42 series valves, see page 107.

**TECHNICAL DATA**

<b>Fluid :</b>	Compressed air, vacuum, inert gases
<b>Pressure range :</b>	Internal Pilot - 2 pos. : 20 to 120 PSI      3 pos. : 40 to 120 PSI External Pilot : vacuum to 120 PSI
<b>Pilot pressure :</b>	2 position : 20 to 120 PSI      3 position : 40 to 120 PSI
<b>Lubrication :</b>	Not required, if used select a medium aniline point lubricant (between 180°F and 210°F)
<b>Filtration :</b>	40 μ
<b>Temperature range :</b>	0°F to 120°F (-18°C to +50°C)
<b>Flow :</b>	# 10-32 : (0.35 C <sub>v</sub> ) - 1/4" O.D. tube receptacle : (0.4 C <sub>v</sub> )
<b>Coil :</b>	Class A wire (#22 AWG x 18), continuous duty
<b>Voltage range :</b>	-1.5% to +10% of nominal voltage
<b>Power :</b>	1.0 to 4.0 W
<b>Response times : (with 24V 4 W coil)</b>	Energize : 5 ms De-energize : 5 ms

- Options :
- M5 ports, M7 ports, 6 mm O.D. tube receptacles
  - Sandwich flow controls : FC42B-BB
  - Sandwich regulator : see 'Regulator' section

**DIMENSIONS**

Dimensions shown are metric (mm)

(SHOWN WITH M7 PORTS)

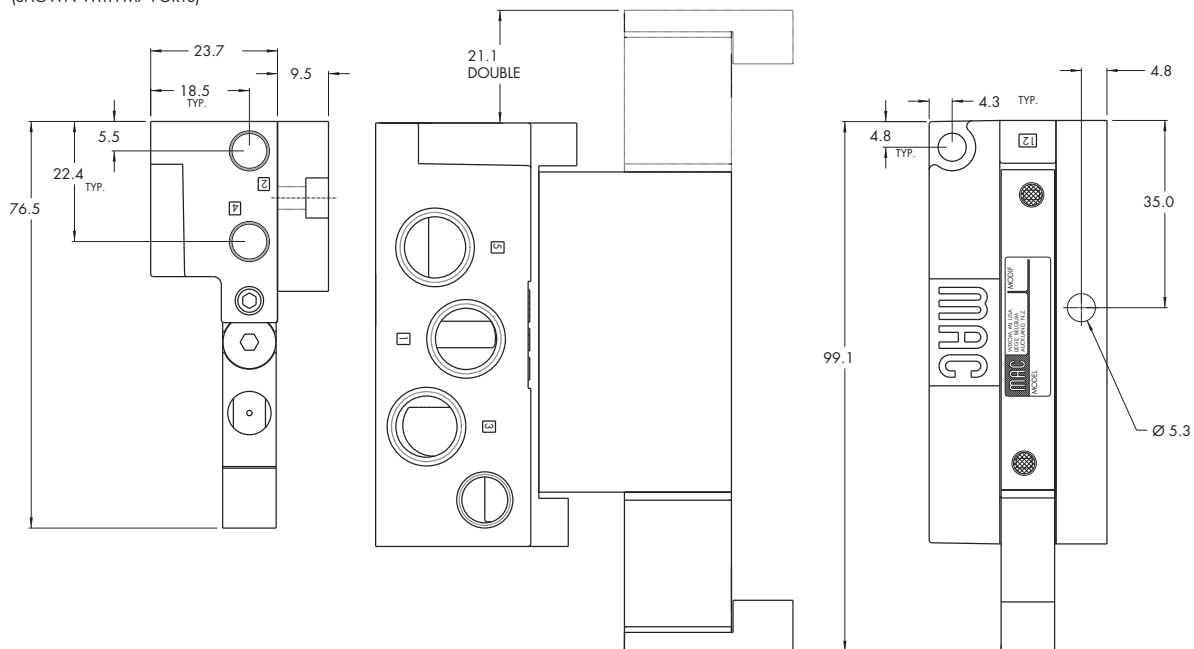



# Direct solenoid and solenoid pilot operated valves

Function	Port size	Flow (Max)	Individual mounting	Series
<b>5/2, 5/3</b>	<b># 10-32 - 1/4" O.D. tube receptacle</b>	<b>0.4 C<sub>v</sub></b>	Sub-base "plug-in"	

### OPERATIONAL BENEFITS

1. 4-way valve with 4-way integral pilot.
2. 10 mm valve (stacks on 10.5 mm centers).
3. High flow (up to 0.4 C<sub>v</sub>).
4. Fast repeatable response times.
5. Maximum shifting forces in both directions.
6. Long life.



### HOW TO ORDER

SINGLE PRESSURE MODELS (LED STANDARD EXCEPT FOR SINGLE SOLENOIDS) - MODELS CODED FOR SIDE PORTS

Port size	Pilot air	5/2 Single solenoid	5/2 Double solenoid	5/3 Closed center	5/3 Open center
<b>Valve less base</b>	Internal	42B-AMA-000-GxxP-xxx	42B-BME-000-GxxP-xST	42B-EME-000-GxxP-xST	42B-FME-000-GxxP-xST
	External	42B-AMD-000-GxxP-xxx	42B-BMH-000-GxxP-xST	42B-EMH-000-GxxP-xST	42B-FMH-000-GxxP-xST
<b># 10-32</b>	Internal	42B-AMA-AAA-GxxP-xxx	42B-BME-AAC-GxxP-xST	42B-EME-AAC-GxxP-xST	42B-FME-AAC-GxxP-xST
	External	42B-AMD-AAB-GxxP-xxx	42B-BMH-AAD-GxxP-xST	42B-EMH-AAD-GxxP-xST	42B-FMH-AAD-GxxP-xST
<b>1/4" O.D. tube receptacles</b>	Internal	42B-AMA-EAA-GxxP-xxx	42B-BME-EAC-GxxP-xST	42B-EME-EAC-GxxP-xST	42B-FME-EAC-GxxP-xST
	External	42B-AMD-EAB-GxxP-xxx	42B-BMH-EAD-GxxP-xST	42B-EMH-EAD-GxxP-xST	42B-FMH-EAD-GxxP-xST

DUAL PRESSURE MODELS (LED STANDARD EXCEPT FOR SINGLE SOLENOIDS) - MODELS CODED FOR SIDE PORTS

Port size	Pilot air	5/2 Single solenoid	5/2 Double solenoid	5/3 Pressure center
<b>Valve less base</b>	Internal	Supply #3 port	42B-CMB-000-GxxP-xxx	42B-DMF-000-GxxP-xST
	Internal	Supply #5 port	42B-CMC-000-GxxP-xxx	42B-DMG-000-GxxP-xST
	External		42B-CMD-000-GxxP-xxx	42B-DMH-000-GxxP-xST
<b># 10-32</b>	Internal	Supply #3 port	42B-CMB-AAA-GxxP-xxx	42B-DMF-AAC-GxxP-xST
	Internal	Supply #5 port	42B-CMC-AAA-GxxP-xxx	42B-DMG-AAC-GxxP-xST
	External		42B-CMD-AAB-GxxP-xxx	42B-DMH-AAD-GxxP-xST
<b>1/4" O.D. tube receptacles</b>	Internal	Supply #3 port	42B-CMB-EAA-GxxP-xxx	42B-DMF-EAC-GxxP-xST
	Internal	Supply #5 port	42B-CMC-EAA-GxxP-xxx	42B-DMG-EAC-GxxP-xST
	External		42B-CMD-EAB-GxxP-xxx	42B-DMH-EAD-GxxP-xST

STANDARD SOLENOID OPERATOR >

G **XX** P-**XXX**\*

XX Voltage	X Manual operator	XX Electrical connection
<b>AA</b> 120 VAC (2.5W)	<b>1</b> Non-locking recessed	<b>Double solenoid &amp; 3 position models</b>
<b>DC</b> 24 VDC (1.8W)	<b>2</b> Locking recessed	<b>ST</b> Base plug-in
<b>DD</b> 24 VDC (2.5W)		<b>Single solenoid models</b>
<b>DF</b> 24 VDC (4.0W)		<b>SA</b> Base plug-in
		<b>SJ</b> Base plug-in with light
		<b>SS</b> Base plug-in with rectifier & light & ground

Note : AC voltage requires connector with rectifier (for double solenoid consult factory).

\* Other options available, see page 311.

Other options available for the 42 series valves, see page 108.

33  
34  
36  
32  
37  
38  
52  
67  
69  
44  
46  
42  
47  
48P  
48  
400  
92  
93  
ISO 01  
ISO 02  
ISO 1  
ISO 2  
ISO 3

**TECHNICAL DATA**

<b>Fluid :</b>	Compressed air, vacuum, inert gases
<b>Pressure range :</b>	Internal Pilot - 2 pos. : 20 to 120 PSI      3 pos. : 40 to 120 PSI External Pilot : vacuum to 120 PSI
<b>Pilot pressure :</b>	2 position : 20 to 120 PSI      3 position : 40 to 120 PSI
<b>Lubrication :</b>	Not required, if used select a medium aniline point lubricant (between 180°F and 210°F)
<b>Filtration :</b>	40 µ
<b>Temperature range :</b>	0°F to 120°F (-18°C to +50°C)
<b>Flow :</b>	# 10-32 : (0.35 C <sub>v</sub> ) – 1/4" O.D. tube receptacle : (0.4 C <sub>v</sub> )
<b>Coil :</b>	Class A continuous duty, #22 AWG x 12 base leads
<b>Voltage range :</b>	-1.5% to +10% of nominal voltage
<b>Power :</b>	1.0 to 4.0 W
<b>Response times : (with 24V 4 W coil)</b>	Energize : 5 ms De-energize : 5 ms

- Options :
- M5 ports, M7 ports, 6 mm O.D. tube receptacles
  - Sandwich flow controls : FC42B-AB
  - Sandwich regulator : see 'Regulator' section

**DIMENSIONS**

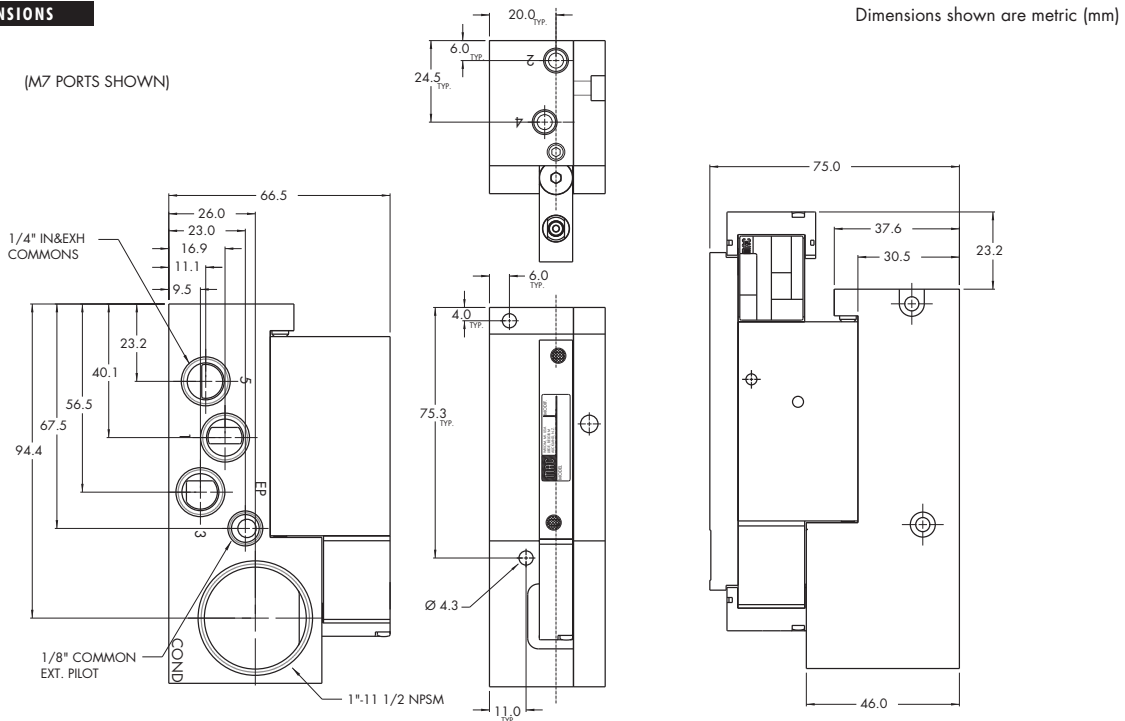



# Direct solenoid and solenoid pilot operated valves

Function	Port size	Flow (Max)	Manifold mounting	Series
<b>5/2, 5/3</b>	<b># 10-32 - 1/4" O.D. tube receptacle</b>	<b>0.4 C<sub>v</sub></b>	Manifold base non "plug-in"	

### OPERATIONAL BENEFITS

1. 4-way valve with 4-way integral pilot.
2. 10 mm valve (stacks on 10.5 mm centers).
3. High flow (up to 0.4 C<sub>v</sub>).
4. Fast repeatable response times.
5. Maximum shifting forces in both directions.
6. Long life.



33  
34  
36  
32  
37  
38  
52  
67  
69  
44  
46

### HOW TO ORDER

#### SINGLE PRESSURE MODELS (MIDDLE STATION MANIFOLDS WITH SIDE PORTS)

Port size	Pilot air	5/2 Single solenoid	5/2 Double solenoid	5/3 Closed center	5/3 Open center
<b>Valve less base</b>	Internal	42B-AMA-000-Gxxx-xxx	42B-BMA-000-Gxxx-xxx	42B-EMA-000-Gxxx-xxx	42B-FMA-000-Gxxx-xxx
	External	42B-AMD-000-Gxxx-xxx	42B-BMD-000-Gxxx-xxx	42B-EMD-000-Gxxx-xxx	42B-FMD-000-Gxxx-xxx
<b># 10-32</b>	Internal	42B-AMA-AJL-Gxxx-xxx	42B-BMA-AJL-Gxxx-xxx	42B-EMA-AJL-Gxxx-xxx	42B-FMA-AJL-Gxxx-xxx
	External	42B-AMD-AJM-Gxxx-xxx	42B-BMD-AJM-Gxxx-xxx	42B-EMD-AJM-Gxxx-xxx	42B-FMD-AJM-Gxxx-xxx
<b>1/4" O.D. tube receptacles</b>	Internal	42B-AMA-EJL-Gxxx-xxx	42B-BMA-EJL-Gxxx-xxx	42B-EMA-EJL-Gxxx-xxx	42B-FMA-EJL-Gxxx-xxx
	External	42B-AMD-EJM-Gxxx-xxx	42B-BMD-EJM-Gxxx-xxx	42B-EMD-EJM-Gxxx-xxx	42B-FMD-EJM-Gxxx-xxx

42  
47  
48P

#### DUAL PRESSURE MODELS (MIDDLE STATION MANIFOLDS WITH SIDE PORTS)

Port size	Pilot air	5/2 Single solenoid	5/2 Double solenoid	5/3 Pressure center
<b>Valve less base</b>	Internal	Supply #3 port	42B-CMB-000-Gxxx-xxx	42B-DMB-000-Gxxx-xxx
		Supply #5 port	42B-CMC-000-Gxxx-xxx	42B-DMC-000-Gxxx-xxx
	External		42B-CMD-000-Gxxx-xxx	42B-DMD-000-Gxxx-xxx
<b># 10-32</b>	Internal	Supply #3 port	42B-CMB-AJL-Gxxx-xxx	42B-DMB-AJL-Gxxx-xxx
		Supply #5 port	42B-CMC-AJL-Gxxx-xxx	42B-DMC-AJL-Gxxx-xxx
	External		42B-CMD-AJM-Gxxx-xxx	42B-DMD-AJM-Gxxx-xxx
<b>1/4" O.D. tube receptacles</b>	Internal	Supply #3 port	42B-CMB-EJL-Gxxx-xxx	42B-DMB-EJL-Gxxx-xxx
		Supply #5 port	42B-CMC-EJL-Gxxx-xxx	42B-DMC-EJL-Gxxx-xxx
	External		42B-CMD-EJM-Gxxx-xxx	42B-DMD-EJM-Gxxx-xxx

48  
400  
92  
93  
ISO 01  
ISO 02  
ISO 1  
ISO 2  
ISO 3

#### STANDARD SOLENOID OPERATOR >

XX Voltage	X Wire length	X Manual operator	XX Electrical connection
<b>AA</b> 120 VAC (2.5W)	<b>A</b> 18"	<b>1</b> Non-locking recessed	<b>BA</b> Flying leads
<b>DC</b> 24 VDC (1.8W)	<b>B</b> 24"	<b>2</b> Locking recessed	<b>BT</b> Flying leads with light
<b>DD</b> 24 VDC (2.5W)	<b>C</b> 36"		<b>GA</b> MAC JAC solenoid plug-in
<b>DF</b> 24 VDC (4.0W)			<b>KA</b> Plug-in wire Assy.
			<b>KT</b> Plug-in wire Assy. with light
			<b>KD</b> Plug-in wire Assy. with rectifier & light & ground

Note : - AC voltage requires connector with rectifier.

\* Other options available, see page 311.

Latching solenoid available for 5/2 valves.

Manifold assemblies consist of (1) left end manifold, (1) right end manifold, and middle station manifolds (options "J" or "K").

Other options available for the 42 series valves, see page 107.

**TECHNICAL DATA**

<b>Fluid :</b>	Compressed air, vacuum, inert gases
<b>Pressure range :</b>	Internal Pilot - 2 pos. : 20 to 120 PSI      3 pos. : 40 to 120 PSI External Pilot : vacuum to 120 PSI
<b>Pilot pressure :</b>	2 position : 20 to 120 PSI      3 position : 40 to 120 PSI
<b>Lubrication :</b>	Not required, if used select a medium aniline point lubricant (between 180°F and 210°F)
<b>Filtration :</b>	40 µ
<b>Temperature range :</b>	0°F to 120°F (-18°C to +50°C)
<b>Flow :</b>	# 10-32 : (0.35 C <sub>v</sub> ) - 1/4" O.D. tube receptacle : (0.4 C <sub>v</sub> )
<b>Coil :</b>	Class A wire (#22 AWG x 18), continuous duty
<b>Voltage range :</b>	-1.5% to +10% of nominal voltage
<b>Power :</b>	1.0 to 4.0 W
<b>Response times :</b> (with 24V 4 W coil)	Energize : 5 ms De-energize : 5 ms

Options :

- M5 ports, M7 ports, 6 mm O.D. tube receptacles
- Sandwich flow controls : FC42B-BB
- Sandwich regulator : see "regulators" section
- Isolator disk for inlet or exhaust: 28454
- Valve blanking plate : M-42004

**DIMENSIONS**

Dimensions shown are metric (mm)

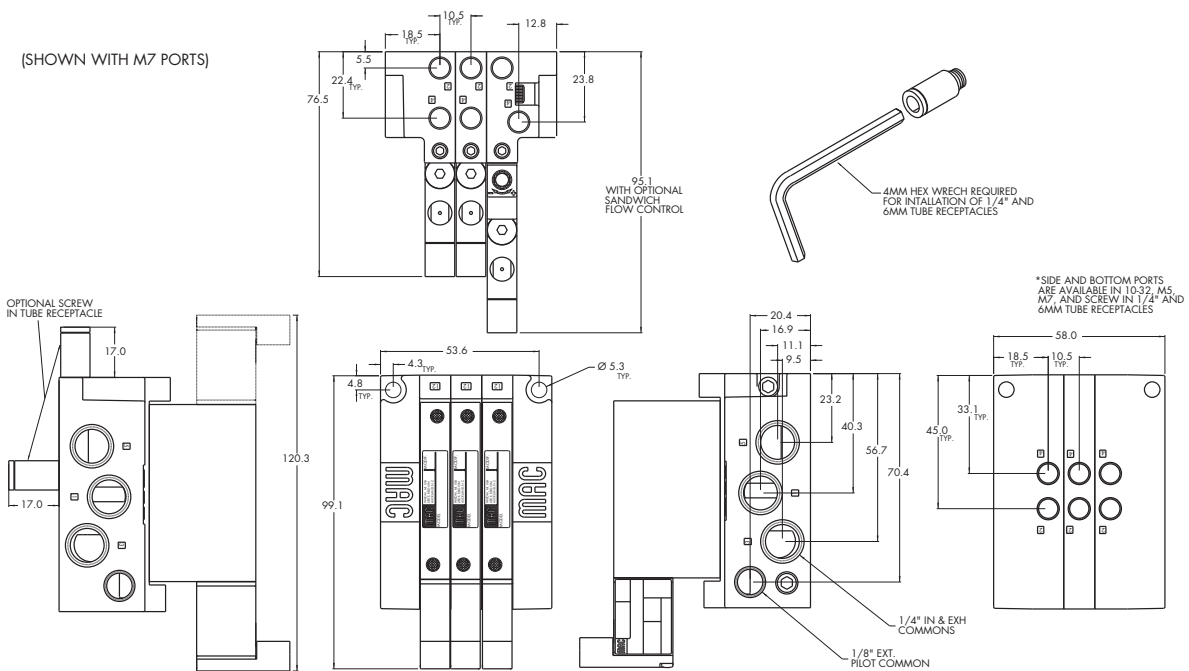





# Direct solenoid and solenoid pilot operated valves

Function	Port size	Flow (Max)	Manifold mounting	Series
<b>5/2, 5/3</b>	<b># 10-32 - 1/4" O.D. tube receptacle</b>	<b>0.4 C<sub>v</sub></b>	Manifold base "plug-in"	

### OPERATIONAL BENEFITS

1. 4-way valve with 4-way integral pilot.
2. 10 mm valve (stacks on 10.5 mm centers).
3. High flow (up to 0.4 C<sub>v</sub>).
4. Fast repeatable response times.
5. Maximum shifting forces in both directions.
6. Long life.



### HOW TO ORDER

SINGLE PRESSURE MODELS (LED STANDARD EXCEPT FOR SINGLE SOLENOIDS)

Port size	Pilot air	5/2 Single solenoid	5/2 Double solenoid	5/3 Closed center	5/3 Open center
<b>Valve less base</b>	Internal	42B-AMA-000-GxxP-xxx	42B-BME-000-GxxP-xST	42B-EME-000-GxxP-xST	42B-FME-000-GxxP-xST
	External	42B-AMD-000-GxxP-xxx	42B-BMH-000-GxxP-xST	42B-EMH-000-GxxP-xST	42B-FMH-000-GxxP-xST
<b># 10-32</b>	Internal	42B-AMA-AJA-GxxP-xxx	42B-BME-AJC-GxxP-xST	42B-EME-AJC-GxxP-xST	42B-FME-AJC-GxxP-xST
	External	42B-AMD-AJB-GxxP-xxx	42B-BMH-AJD-GxxP-xST	42B-EMH-AJD-GxxP-xST	42B-FMH-AJD-GxxP-xST
<b>1/4" O.D. tube receptacles</b>	Internal	42B-AMA-EJA-GxxP-xxx	42B-BME-EJC-GxxP-xST	42B-EME-EJC-GxxP-xST	42B-FME-EJC-GxxP-xST
	External	42B-AMD-EJB-GxxP-xxx	42B-BMH-EJD-GxxP-xST	42B-EMH-EJD-GxxP-xST	42B-FMH-EJD-GxxP-xST

DUAL PRESSURE MODELS (LED STANDARD EXCEPT FOR SINGLE SOLENOIDS)

Port size	Pilot air	5/2 Single solenoid	5/2 Double solenoid	5/3 Pressure center
<b>Valve less base</b>	Internal	Supply #3 port	42B-CMB-000-GxxP-xxx	42B-DMF-000-GxxP-xST
	Internal	Supply #5 port	42B-CMC-000-GxxP-xxx	42B-DMG-000-GxxP-xST
	External		42B-CMD-000-GxxP-xxx	42B-DMH-000-GxxP-xST
<b># 10-32</b>	Internal	Supply #3 port	42B-CMB-AJA-GxxP-xxx	42B-DMF-AJC-GxxP-xST
	Internal	Supply #5 port	42B-CMC-AJA-GxxP-xxx	42B-DMG-AJC-GxxP-xST
	External		42B-CMD-AJB-GxxP-xxx	42B-DMH-AJD-GxxP-xST
<b>1/4" O.D. tube receptacles</b>	Internal	Supply #3 port	42B-CMB-EJA-GxxP-xxx	42B-DMF-EJC-GxxP-xST
	Internal	Supply #5 port	42B-CMC-EJA-GxxP-xxx	42B-DMG-EJC-GxxP-xST
	External		42B-CMD-EJB-GxxP-xxx	42B-DMH-EJD-GxxP-xST

STANDARD SOLENOID OPERATOR >

G **XX** P-**XXX**

Above numbers are middle station manifolds with side ports

XX Voltage	X Manual operator	XX Electrical connection
<b>AA</b> 120 VAC (2.5W)	<b>1</b> Non-locking recessed	<b>Double solenoid &amp; 3 position models</b>
<b>DC</b> 24 VDC (1.8W)	<b>2</b> Locking recessed	<b>ST</b> Base plug-in
<b>DD</b> 24 VDC (2.5W)		<b>Single solenoid models</b>
<b>DF</b> 24 VDC (4.0W)		<b>SA</b> Base plug-in
		<b>SJ</b> Base plug-in with light
		<b>SS</b> Base plug-in with rectifier & light & ground

\* Other options available, see page 311.  
\*\* Latching solenoid available for 5/2 valves.

Note : - AC voltage requires connector with rectifier (for double solenoid consult factory).  
- Manifold assemblies consist of (1) left end manifold, (1) right end manifold, and middle station manifolds (options "J" or "K").

Other options available for the 42 series valves, see page 108.

33  
34  
36  
32  
37  
38  
52  
67  
69  
44  
46  
42  
47  
48P  
48  
400  
92  
93  
ISO 01  
ISO 02  
ISO 1  
ISO 2  
ISO 3

**TECHNICAL DATA**

<b>Fluid :</b>	Compressed air, vacuum, inert gases
<b>Pressure range :</b>	Internal Pilot - 2 pos. : 20 to 120 PSI      3 pos. : 40 to 120 PSI External Pilot : vacuum to 120 PSI
<b>Pilot pressure :</b>	2 position : 20 to 120 PSI      3 position : 40 to 120 PSI
<b>Lubrication :</b>	Not required, if used select a medium aniline point lubricant (between 180°F and 210°F)
<b>Filtration :</b>	40 µ
<b>Temperature range :</b>	0°F to 120°F (-18°C to +50°C)
<b>Flow :</b>	# 10-32 : (0.35 C <sub>v</sub> ) - 1/4" O.D. tube receptacle : (0.4 C <sub>v</sub> )
<b>Coil :</b>	Class A continuous duty, #22 AWG x 12 base leads
<b>Voltage range :</b>	-1.5% to +10% of nominal voltage
<b>Power :</b>	1.0 to 4.0 W
<b>Response times :</b> (with 24V 4 W coil)	Energize : 5 ms De-energize : 5 ms

Options :

- M5 ports, M7 ports, 6 mm O.D. tube receptacles
- Sandwich flow controls : FC42B-AB
- Sandwich regulator : see "regulators" section
- Isolator disk for inlet or exhaust: 28454
- Valve blanking plate : M-42004
- Plug-in wire protector : 24180

**DIMENSIONS**

Dimensions shown are metric (mm)

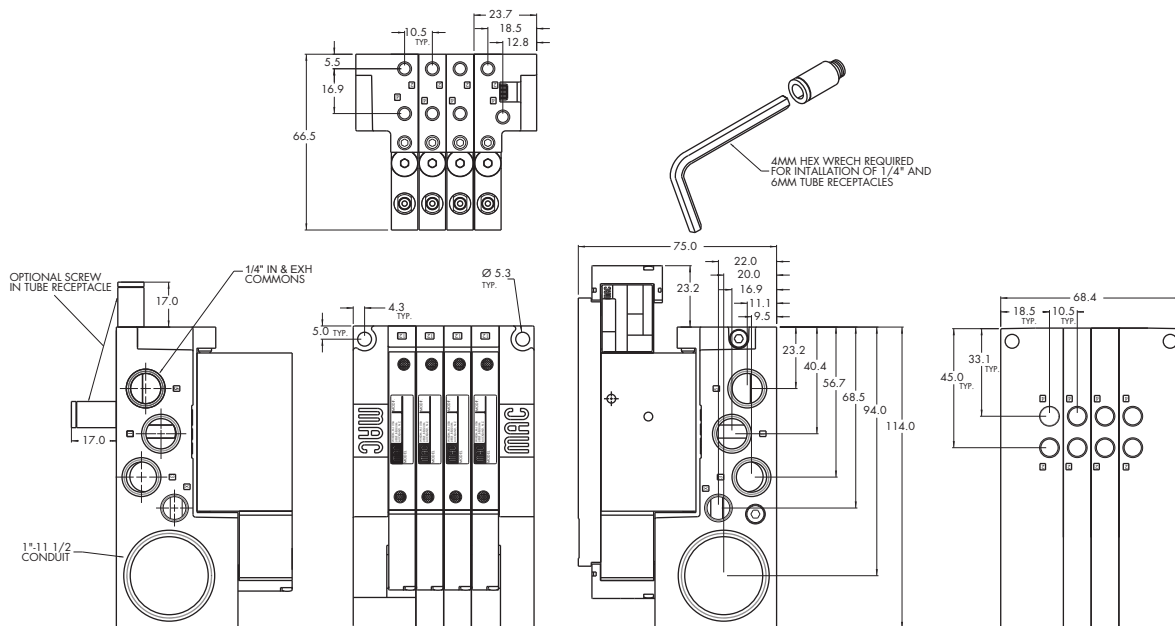

<b>OPTIONS FOR NON PLUG-IN VALVES</b>	<b>33</b>
<b>Base type :</b>	<b>34</b>
<b>Individual base</b>	<b>36</b>
42B-XXX-X <b>A</b> X-Gxxx-xxx	
<b>A</b> Individual base – Side ports	
<b>B</b> Individual base – Bottom ports	
<b>Manifold base</b>	<b>32</b>
42B-XXX-X <b>J</b> X-Gxxx-xxx	
<b>J</b> Manifold base – Side ports	
<b>K</b> Manifold base – Bottom ports	
<b>L</b> Left end manifold base – Side ports	
<b>M</b> Left end manifold base – Bottom ports	
<b>N</b> Right end manifold base – Side ports	
<b>P</b> Right end manifold base – Bottom ports	
<b>Universal spool</b>	<b>37</b>
42B-R <b>X</b> X-XXX-Gxxx-xxx	<b>38</b>
<b>R</b> 2 position single solenoid universal spool	<b>52</b>
<b>S</b> 2 position double solenoid universal spool	<b>67</b>
<b>Base only :</b>	<b>69</b>
42B-000-XXX (i.e. 42B-000-AAL) - Individual base	<b>44</b>
42B-000-XXX (i.e. 42B-000-AJL) - Manifold base	<b>46</b>
<b>Pilot style :</b>	<b>42</b>
42B-X <b>M</b> X-XXX-Gxxx-xxx	<b>47</b>
<b>M</b> Pilot exhaust muffled	<b>48P</b>
<b>P</b> Pilot exhaust piped (# 10-32)	
<b>U</b> Pilot exhaust to main exhaust	
	<b>48</b>
	<b>400</b>
	<b>92</b>
	<b>93</b>
	<b>ISO 01</b>
	<b>ISO 02</b>
	<b>ISO 1</b>
	<b>ISO 2</b>
	<b>ISO 3</b>

**OPTIONS FOR  
PLUG-IN VALVES**

**Base type :**

**Individual base**

42B-XXX-**AX**-GxxP-xxx

- A** Individual base – Side ports
- B** Individual base – Bottom ports

**Manifold base**

42B-XXX-**XJX**-GxxP-xxx

- J** Manifold base – Side ports
- K** Manifold base – Bottom ports
- L** Left end manifold base – Side ports
- M** Left end manifold base – Bottom ports
- N** Right end manifold base – Side ports
- P** Right end manifold base – Bottom ports

**Universal spool**

42B-**RXX**-XXX-GxxP-xxx

- R** 2 position single solenoid universal spool
- S** 2 position double solenoid universal spool

**Base only :**

42B-000-XXX (i.e. 42B-000-AAC)

- Individual base wired for a double solenoid

42B-000-XXX (i.e. 42B-000-AJA)

- Manifold base wired for a single solenoid

**For LED with diode (2 & 3 position double solenoid valves)**

42B-XX**J**-XXX-GxxP-xST

- J** Internal pilot single pressure
- K** Internal pilot dual pressure supply from #3 port
- L** Internal pilot dual pressure supply from #5 port
- M** External pilot

**Pilot style :**

42B-**XXM**-XXX-GxxP-xxx

- M** Pilot exhaust muffled
- P** Pilot exhaust piped (# 10-32)
- U** Pilot exhaust to main exhaust

Individual mounting

Inline	Sub-base non "plug-in"
--------	------------------------

Series

Manifold mounting

Stacking	Manifold base "plug-in"
----------	-------------------------

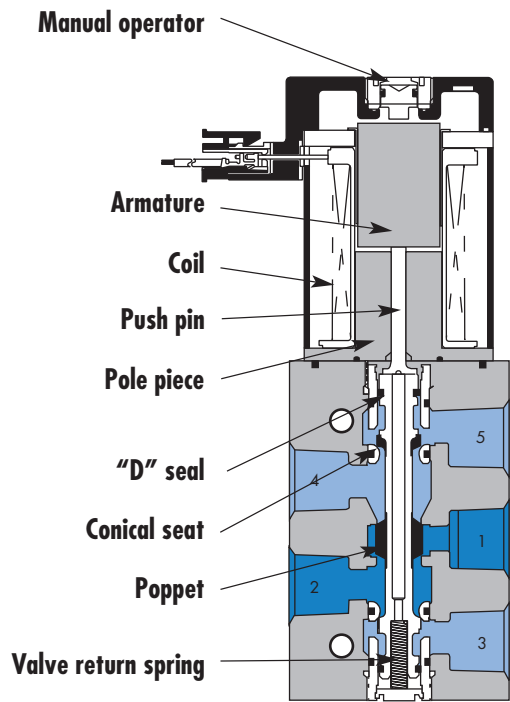

33

34

36

32

37

38

52

67

69

44

46

48

42

47

48P

48

400

92

93

**SERIES FEATURES**

- Short stroke solenoid produces high energization shifting force.
- High force return spring due to high force solenoid maximizes both energization and de-energization shifting forces.
- Built-in wear compensation - valve stroke is shorter than solenoid stroke.
- Four (4) bonded balanced poppets on a one-piece valve stem.
- End poppets seal first on conical seats and cushion inlet poppet, eliminating cutting.
- Exhaust seals are not under inlet pressure thus reducing friction.
- Short stroking balanced poppet allows for direct solenoid operation with high shifting forces, minimized friction, fast response and high flow in a small package.

ISO 01

ISO 02

ISO 1

ISO 2

ISO 3



Function	Port size	Flow (Max)	Individual Mounting	Series
<b>5/2</b>	<b>1/8" - 1/4"</b>	<b>0.5 C<sub>v</sub></b>	Inline	

### OPERATIONAL BENEFITS

- Short stroke solenoid produces high energization shifting force.
- High force return spring due to high force solenoid maximizes both energization and de-energization shifting forces.
- Built-in wear compensation – valve stroke is shorter than solenoid stroke.
- Four bonded balanced poppets on a one-piece valve stem.
- End poppets seal first on conical seats and cushion inlet poppet, eliminating cutting.
- Exhaust seals are not under inlet pressure thus reducing friction.
- Integral non-rising flow controls available on inline models.
- Short stroking balanced poppet allows for direct solenoid operation with high shifting forces, minimized friction, fast response and high flow in a small package.



### HOW TO ORDER

Port size	Without flow controls	With flow controls
		
<b>1/8" NPTF</b>	47A-AA0-H <b>xxx-xxx</b>	47A-BA0-H <b>xxx-xxx</b>
<b>1/4" NPTF</b>	47A-AB0-H <b>xxx-xxx</b>	47A-BB0-H <b>xxx-xxx</b>

### SOLENOID OPERATOR ▶

H **XXX-XXX\***

XX Voltage	X Lead Wire length	X Manual operator	XX Electrical connection
<b>DA</b> 24 VDC (5.2W)	<b>A</b> 18"	<b>1</b> Non-locking recessed	<b>MA</b> Plug-in wire assembly
<b>DB</b> 24 VDC (2.4W)	<b>B</b> 24"	<b>2</b> Locking recessed	<b>MC</b> Plug-in wire assembly with light
<b>DC</b> 24 VDC (1.8W)	<b>C</b> 36"		<b>BA</b> Flying leads
<b>DD</b> 24 VDC (1.0W)			<b>BC</b> Flying leads with light
<b>AA</b> 120 VAC (6.7W)			<b>MT</b> Plug-in wire assembly with rectifier & light

\* Other options available, see page 315.  
Note: AC voltage requires connector with rectifier.

\* Other options available, see page 319.

### OPTIONS

#### Namur Mount Option (w/o flow controls)

47A-CXO-H**xxx-xxx**

- A** 1/8" NPTF
- B** 1/4" NPTF

33  
34  
36  
32  
37  
38  
52  
67  
69  
44  
46  
42  
47  
48P  
48  
400  
92  
93  
ISO 01  
ISO 02  
ISO 1  
ISO 2  
ISO 3

**TECHNICAL DATA**

<b>Fluid :</b>	Compressed air, vacuum, inert gases
<b>Pressure range :</b>	Vacuum to 120 PSI
<b>Lubrication :</b>	Not required, if used select a medium aniline point lubricant (between 180°F and 210°F)
<b>Filtration :</b>	40 μ
<b>Temperature range :</b>	0°F to 120°F (-18°C to +50°C)
<b>Flow :</b>	5.2W : (0.50 C <sub>v</sub> ) – 2.4W : (0.35 C <sub>v</sub> ) – 1.0W : (0.30 C <sub>v</sub> )
<b>Coil :</b>	Class A wire (#22 AWG x 18), continuous duty
<b>Voltage range :</b>	-1.5% to +10% of nominal voltage
<b>Power :</b>	5.2W – 2.4W – 1.0W
<b>Response times : (with 5.2 W coil)</b>	Energize : 17.4 ms De-energize : 3.8 ms

- Options :                   • BSPP threads
- Spare parts :             • Flow control assembly : N-47004

**DIMENSIONS**

Dimensions shown are metric (mm)

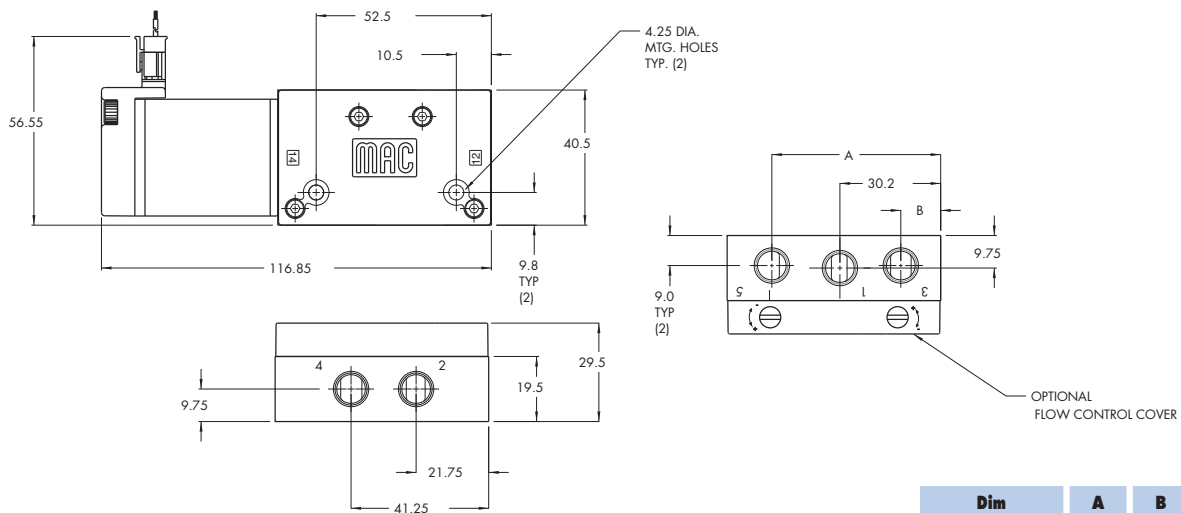

Dim	A	B
<b>1/8"</b>	50.6	11.95
<b>1/4"</b>	49.2	11.2

Function	Port size	Flow (Max)	Individual Mounting	Series
<b>5/2</b>	<b>1/8" - 1/4"</b>	<b>0.5 C<sub>v</sub></b>	Sub-base non "plug-in"	

### OPERATIONAL BENEFITS

- Short stroke solenoid produces high energization shifting force.
- High force return spring due to high force solenoid maximizes both energization and de-energization shifting forces.
- Built-in wear compensation – valve stroke is shorter than solenoid stroke.
- Four bonded balanced poppets on a one-piece valve stem.
- End poppets seal first on conical seats and cushion inlet poppet, eliminating cutting.
- Exhaust seals are not under inlet pressure thus reducing friction.
- Integral non-rising flow controls available on inline models.
- Short stroking balanced poppet allows for direct solenoid operation with high shifting forces, minimized friction, fast response and high flow in a small package.



### HOW TO ORDER

Port size	Without flow controls	With flow controls
<b>Valve less base</b>	47A-L10-H XXX-XXX	47A-L10-H XXX-XXX
<b>1/8" NPTF</b>	47A-LAA-H XXX-XXX	47A-LAB-H XXX-XXX
<b>1/4" NPTF</b>	47A-LBA-H XXX-XXX	47A-LBB-H XXX-XXX

### SOLENOID OPERATOR ▶

H XXX-XXX*			
XX Voltage	X Lead Wire length	X Manual operator	XX Electrical connection
<b>DA</b> 24 VDC (5.2W)	<b>A</b> 18"	<b>1</b> Non-locking recessed	<b>MA</b> Plug-in wire assembly
<b>DB</b> 24 VDC (2.4W)	<b>B</b> 24"	<b>2</b> Locking recessed	<b>MC</b> Plug-in wire assembly with light
<b>DC</b> 24 VDC (1.8W)	<b>C</b> 36"		<b>BA</b> Flying leads
<b>DD</b> 24 VDC (1.0W)			<b>BC</b> Flying leads with light
<b>AA</b> 120 VAC (6.7W)			<b>MT</b> Plug-in wire assembly with rectifier & light

\* Other options available, see page 315.  
Note: AC voltage requires connector with rectifier.

\* Other options available, see page 319.

33  
34  
36  
32  
37  
38  
52  
67  
69  
44  
46  
42  
47  
48P  
48  
400  
92  
93  
ISO 01  
ISO 02  
ISO 1  
ISO 2  
ISO 3



**TECHNICAL DATA**

<b>Fluid :</b>	Compressed air, vacuum, inert gases
<b>Pressure range :</b>	Vacuum to 120 PSI
<b>Lubrication :</b>	Not required, if used select a medium aniline point lubricant (between 180°F and 210°F)
<b>Filtration :</b>	40 μ
<b>Temperature range :</b>	0°F to 120°F (-18°C to +50°C)
<b>Flow :</b>	5.2W : (0.50 C <sub>v</sub> ) – 2.4W : (0.35 C <sub>v</sub> ) – 1.0W : (0.30 C <sub>v</sub> )
<b>Coil :</b>	Class A wire (#22 AWG x 18), continuous duty
<b>Voltage range :</b>	-1.5% to +10% of nominal voltage
<b>Power :</b>	5.2W – 2.4W – 1.0W
<b>Response times : (with 5.2 W coil)</b>	Energize : 17.4 ms De-energize : 3.8 ms

- Options :
- BSPP threads
- Spare parts :
- Pressure seal body to base: 16628
  - Mounting screw (x2): 35043
  - Flow control assembly (x2): N-04001

**DIMENSIONS**

Dimensions shown are metric (mm)

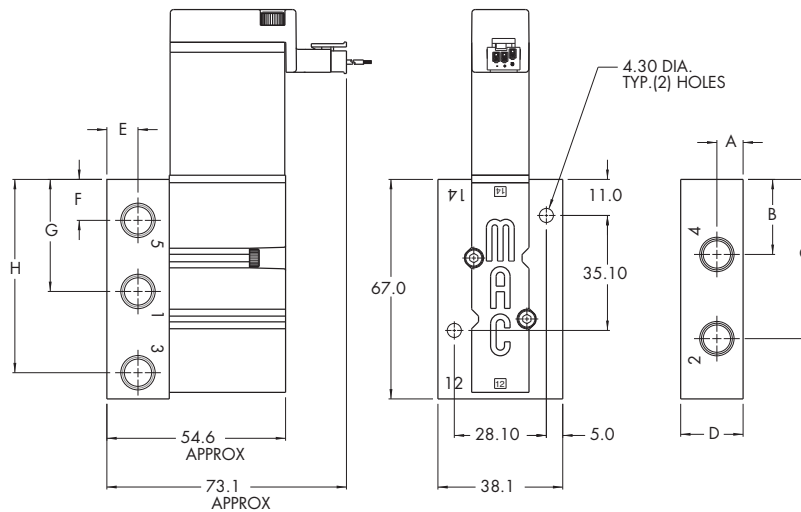

DIM.	A	B	C	D	E	F	G	H
1/8"	8.0	22.9	48.6	19.05	9.5	12.5	34.2	59.0
1/4"	9.5	24.0	48.8	23.0	12.5	12.8	34.2	57.2



Function	Port size	Flow (Max)	Manifold Mounting	Series
<b>5/2</b>	<b>1/8" - 1/4"</b>	<b>0.5 C<sub>v</sub></b>	Stacking	

**OPERATIONAL BENEFITS**

- Short stroke solenoid produces high energization shifting force.
- High force return spring due to high force solenoid maximizes both energization and de-energization shifting forces.
- Built-in wear compensation – valve stroke is shorter than solenoid stroke.
- Four bonded balanced poppets on a one-piece valve stem.
- End poppets seal first on conical seats and cushion inlet poppet, eliminating cutting.
- Exhaust seals are not under inlet pressure thus reducing friction.
- Integral non-rising flow controls available on inline models.
- Short stroking balanced poppet allows for direct solenoid operation with high shifting forces, minimized friction, fast response and high flow in a small package.



**HOW TO ORDER**

Port size	Without flow controls	With flow controls
		
<b>1/8" NPTF</b>	47A-SA0-H <b>xxx-xxx</b>	47A-TA0-H <b>xxx-xxx</b>
<b>1/4" NPTF</b>	47A-SB0-H <b>xxx-xxx</b>	47A-TB0-H <b>xxx-xxx</b>

**SOLENOID OPERATOR >**

**H XXX-XXX\***

XX Voltage	X Lead Wire length	X Manual operator	XX Electrical connection
<b>DA</b> 24 VDC (5.2W)	<b>A</b> 18"	<b>1</b> Non-locking recessed	<b>MA</b> Plug-in wire assembly
<b>DB</b> 24 VDC (2.4W)	<b>B</b> 24"	<b>2</b> Locking recessed	<b>MC</b> Plug-in wire assembly with light
<b>DC</b> 24 VDC (1.8W)	<b>C</b> 36"		<b>BA</b> Flying leads
<b>DD</b> 24 VDC (1.0W)			<b>BC</b> Flying leads with light
<b>AA</b> 120 VAC (6.7W)			<b>MT</b> Plug-in wire assembly with rectifier & light

\* Other options available, see page 315.  
Note: AC voltage requires connector with rectifier.

**LATCHING OPERATOR >**

**L XXX-XXX\***

XX Voltage	X Lead Wire length	X Manual operator	XX Electrical connection
<b>DA</b> 24 VDC (5.2W)	<b>A</b> 18"	<b>0</b> No operator	<b>BA</b> 2 Wire Flying leads
<b>DF</b> 12 VDC (5.2W)	<b>B</b> 24"		<b>BJ</b> 4 Wire Flying leads
	<b>C</b> 36"		<b>LA</b> 3 Wire Plug-in (Polarity switching cover)
			<b>MA</b> 2 Wire Plug-in
			<b>ME</b> 4 Wire Plug-in

\* Other options available, see page 319.  
End plate kit required: M-47013-01 (1/4" NPTF).

33  
34  
36  
32  
37  
38  
52  
67  
69  
44  
46  
42  
47  
48P  
48  
400  
92  
93  
ISO 01  
ISO 02  
ISO 1  
ISO 2  
ISO 3

**TECHNICAL DATA**

<b>Fluid :</b>	Compressed air, vacuum, inert gases
<b>Pressure range :</b>	Vacuum to 120 PSI
<b>Lubrication :</b>	Not required, if used select a medium aniline point lubricant (between 180°F and 210°F)
<b>Filtration :</b>	40 µ
<b>Temperature range :</b>	0°F to 120°F (-18°C to +50°C)
<b>Flow :</b>	5.2W : (0.50 C <sub>v</sub> ) – 2.4W : (0.35 C <sub>v</sub> ) – 1.0W : (0.30 C <sub>v</sub> )
<b>Coil :</b>	Class A wires (#22 AWG x 18), continuous duty
<b>Voltage range :</b>	-1.5% to +10% of nominal voltage
<b>Power :</b>	5.2W – 2.4W – 1.0W
<b>Response times : (with 5.2 W coil)</b>	Energize : 17.4 ms De-energize : 3.8 ms

- Options : • BSPP threads
- Spare parts : • Inlet isolator: 28451 • Exhaust isolator: N-47009 • Tie Rod (x2): 79057

**DIMENSIONS**

Dimensions shown are metric (mm)

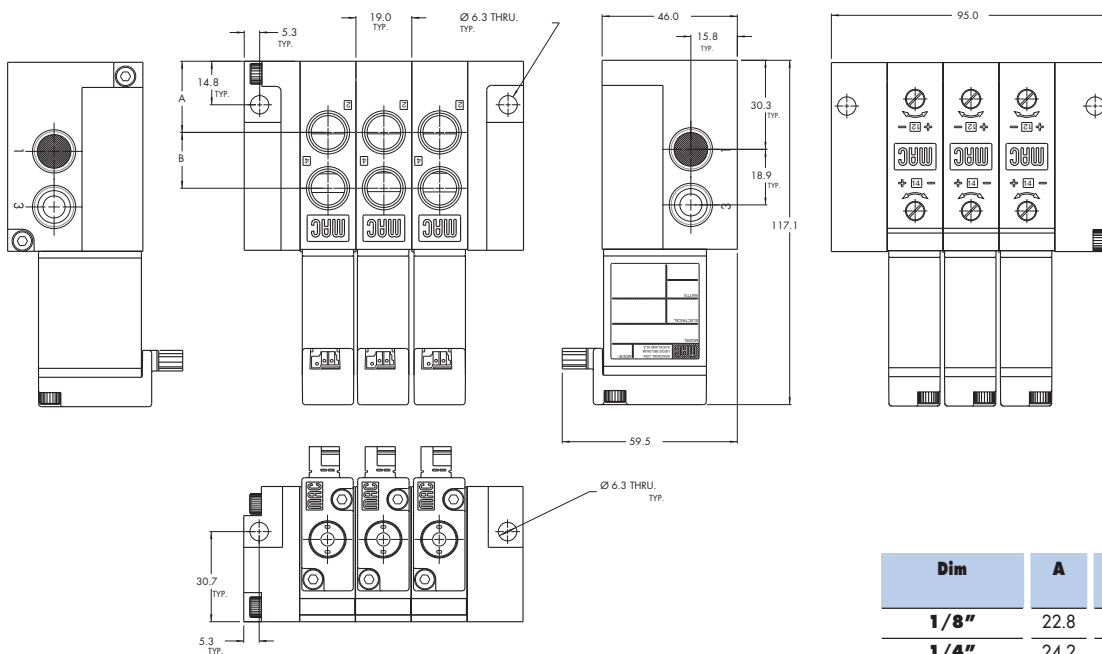

Dim	A	B
1/8"	22.8	18.4
1/4"	24.2	19

Function	Port size	Flow (Max)	Manifold Mounting	Series
5/2	1/8" - 1/4"	0.5 C <sub>v</sub>	Manifold base "plug-in"	

### OPERATIONAL BENEFITS

- Short stroke solenoid produces high energization shifting force.
- High force return spring due to high force solenoid maximizes both energization and de-energization shifting forces.
- Built-in wear compensation – valve stroke is shorter than solenoid stroke.
- Four bonded balanced poppets on a one-piece valve stem.
- End poppets seal first on conical seats and cushion inlet poppet, eliminating cutting.
- Exhaust seals are not under inlet pressure thus reducing friction.
- Integral non-rising flow controls available on inline models.
- Short stroking balanced poppet allows for direct solenoid operation with high shifting forces, minimized friction, fast response and high flow in a small package.

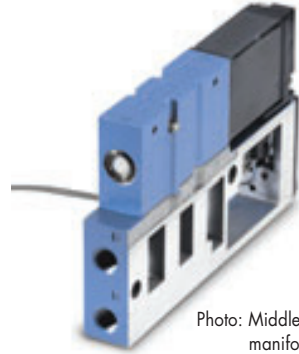

Photo: Middle station manifold base

### HOW TO ORDER

Port size	Model number
<b>Valve less base</b>	47A-L10-H <b>XX</b> P- <b>XXX</b>
<b>1/8" NPTF</b>	47A-LAJ-H <b>XX</b> P- <b>XXX</b>
<b>1/4" NPTF</b>	47A-LBJ-H <b>XX</b> P- <b>XXX</b>



### SOLENOID OPERATOR >

## H **XX** P-**XXX**\*

<b>XX</b> Voltage	<b>X</b> Manual operator	<b>XX</b> Electrical connection
<b>DA</b> 24 VDC (5.2W)	<b>1</b> Non-locking recessed	<b>FA</b> Base plug-in
<b>DB</b> 24 VDC (2.4W)	<b>2</b> Locking recessed	<b>FB</b> Base plug-in w/ ground
<b>DC</b> 24 VDC (1.8W)		<b>FC</b> Base plug-in w/ LED light
<b>DD</b> 24 VDC (1.0W)		<b>FD</b> Base plug-in w/ LED light w/ ground
<b>AA</b> 120 VAC (6.7W)		<b>FT</b> Base plug-in w/ rectifier and light

\* Other options available, see page 315.  
Note : AC voltage requires connector with rectifier.

### LATCHING SOLENOID >

## L **XX** P-**XXX**\*

<b>XX</b> Voltage	<b>X</b> Manual operator	<b>XX</b> Electrical connection
<b>DA</b> 24 VDC (5.2W)	<b>0</b> No operator	<b>FA</b> Base plug-in w/ ground
<b>DF</b> 12 VDC (5.2W)		<b>FB</b> Base plug-in w/ ground & LED
		<b>FC</b> Base plug-in 4 wire w/ ground
		<b>FD</b> Base Plug-in 4 wire w/ LED & ground

\* Other options available, see page 319.

### OPTIONS

47A-**XXJ**-**XXX**P-**XXX**

- J** Manifold base, side cylinders (middle station)
- K** Manifold base, bottom cylinders (middle station)
- L** Right end manifold base, side cylinders
- M** Right end manifold base, bottom cylinders
- N** Left end manifold base, side cylinders
- P** Left end manifold base, bottom cylinders

Note: Manifold assemblies consist of (1) left end manifold, (1) right end manifold, and middle station manifolds.

33  
34  
36  
32  
37  
38  
52  
67  
69  
44  
46  
42  
47  
48P  
48  
400  
92  
93  
ISO 01  
ISO 02  
ISO 1  
ISO 2  
ISO 3

**TECHNICAL DATA**

<b>Fluid :</b>	Compressed air, vacuum, inert gases
<b>Pressure range :</b>	Vacuum to 120 PSI
<b>Lubrication :</b>	Not required, if used select a medium aniline point lubricant (between 180°F and 210°F)
<b>Filtration :</b>	40 μ
<b>Temperature range :</b>	0°F to 120°F (-18°C to +50°C)
<b>Flow (at 6 bar, ΔP=1bar) :</b>	5.2W : (0.50 C <sub>v</sub> ) – 2.4W : (0.35 C <sub>v</sub> ) – 1.0W : (0.30 C <sub>v</sub> )
<b>Coil :</b>	Class A continuous duty, #22 AWG x 12 base leads
<b>Voltage range :</b>	-1.5% to +10% of nominal voltage
<b>Power :</b>	5.2W – 2.4W – 1.0W
<b>Response times : (with 5,2 W coil)</b>	Energize : 17.4 ms De-energize : 3.8 ms

- Options : • BSPP threads • Sandwich flow control: FC47A-AA • Sandwich regulator: see "Regulator" section
- Spare parts : • Inlet/exhaust isolator: 28447 • Valve cover plate: M-47001

**DIMENSIONS**

Dimensions shown are metric (mm)

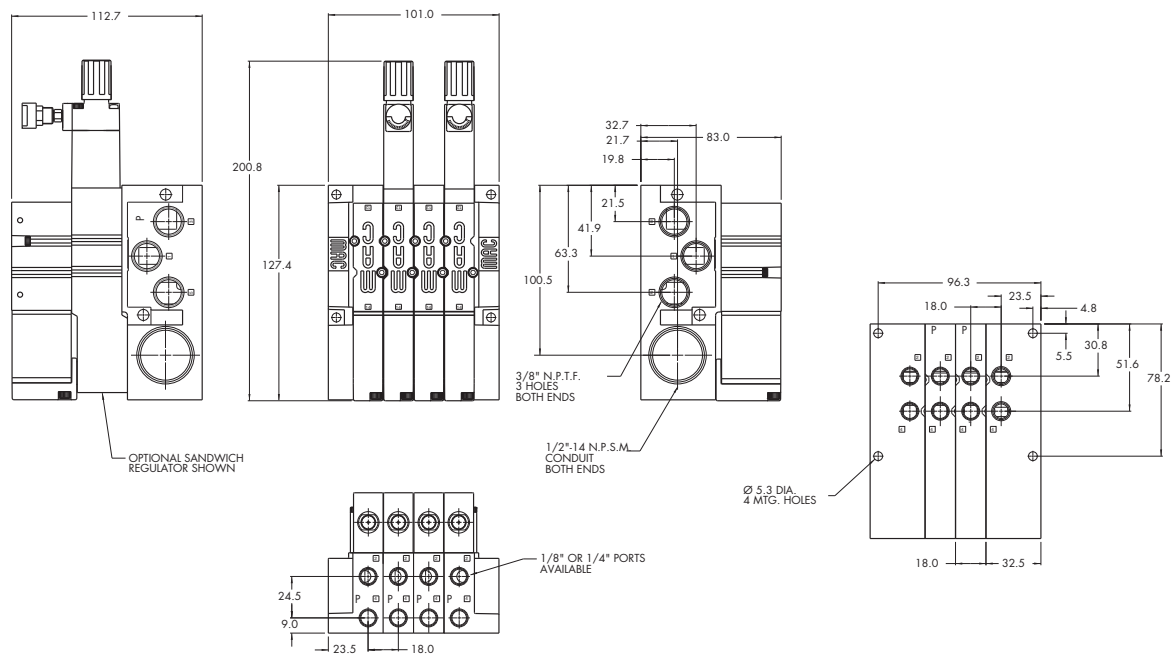

## Individual mounting

Sub-base non "plug-in"	Sub-base "plug-in"	Sub-base/manifold base non "plug-in" with latching solenoid	Sub-base/manifold base "plug-in" with latching solenoid
------------------------	--------------------	---	---

Series

## Manifold mounting

Manifold base non "plug-in"	Manifold base "plug-in"	Sub-base/manifold base non "plug-in" with latching solenoid	Sub-base/manifold base "plug-in" with latching solenoid
-----------------------------	-------------------------	---	---

33

34

36

32

37

38

52

67

69

44

46

42

47

48P

48

400

92

93

ISO 01

ISO 02

ISO 1

ISO 2

ISO 3

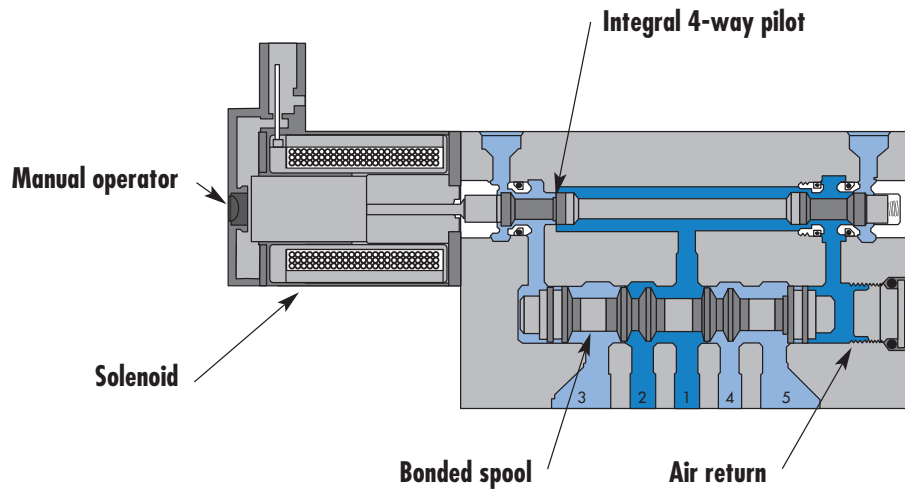

## SERIES FEATURES

- High force MACSOLENOID®.
- Integral 4-way pilot design.
- Single or dual pressure.
- Internal or external pilot.
- Single or double solenoid.
- 2 or 3 position.
- Rectified AC voltage.
- Latching solenoid technology.



# Direct solenoid and solenoid pilot operated valves

Function	Port size	Flow (Max)	Individual mounting	Series
<b>5/2, 5/3</b>	<b>1/8"</b>	<b>1.1 C<sub>v</sub></b>	Sub-base non "plug-in"	

### OPERATIONAL BENEFITS

1. 4-way valve with 4-way integral pilot.
2. 16 mm valve (stacks on 16.5 mm centers).
3. High flow (up to 1.1 C<sub>v</sub>).
4. Fast repeatable response times.
5. Maximum shifting forces in both directions.
6. Long life.



33  
34  
36  
32  
37  
38  
52  
67  
69  
44

### HOW TO ORDER

#### SINGLE PRESSURE MODELS (VALVE WITH BASE CODED FOR SIDE PORTS)

Port size	Pilot air	5/2 Single solenoid	5/2 Double solenoid	5/3 Closed center	5/3 Open center
<b>Valve less base</b>	Internal	48B-AMA-000-Gxxx-xxx	48B-BMA-000-Gxxx-xxx	48B-EMA-000-Gxxx-xxx	48B-FMA-000-Gxxx-xxx
	External	48B-AMD-000-Gxxx-xxx	48B-BMD-000-Gxxx-xxx	48B-EMD-000-Gxxx-xxx	48B-FMD-000-Gxxx-xxx
<b>1/8" NPTF</b>	Internal	48B-AMA-AAL-Gxxx-xxx	48B-BMA-AAL-Gxxx-xxx	48B-EMA-AAL-Gxxx-xxx	48B-FMA-AAL-Gxxx-xxx
	External	48B-AMD-AAM-Gxxx-xxx	48B-BMD-AAM-Gxxx-xxx	48B-EMD-AAM-Gxxx-xxx	48B-FMD-AAM-Gxxx-xxx

#### DUAL PRESSURE MODELS (VALVE WITH BASE CODED FOR SIDE PORTS)

Port size	Pilot air	5/2 Single solenoid	5/2 Double solenoid	5/3 Pressure center
<b>Valve less base</b>	Internal	Supply #3 port 48B-CMB-000-Gxxx-xxx	48B-DMB-000-Gxxx-xxx	48B-HMB-000-Gxxx-xxx
	External	Supply #5 port 48B-CMC-000-Gxxx-xxx	48B-DMC-000-Gxxx-xxx	48B-HMC-000-Gxxx-xxx
<b>1/8" NPTF</b>	Internal	Supply #3 port 48B-CMB-AAL-Gxxx-xxx	48B-DMB-AAL-Gxxx-xxx	48B-HMB-AAL-Gxxx-xxx
	External	Supply #5 port 48B-CMC-AAL-Gxxx-xxx	48B-DMC-AAL-Gxxx-xxx	48B-HMC-AAL-Gxxx-xxx

46  
42  
47  
48P  
48

#### STANDARD SOLENOID OPERATOR >

G **XXX-XXX**\*

XX Voltage	X Wire length	X Manual operator	XX Electrical connection
<b>AA</b> 120 VAC (2.5W)	<b>A</b> 18"	<b>1</b> Non-locking recessed	<b>BA</b> Flying leads
<b>DC</b> 24 VDC (1.8W)	<b>B</b> 24"	<b>2</b> Locking recessed	<b>BT</b> Flying leads with light
<b>DD</b> 24 VDC (2.5W)	<b>C</b> 36"		<b>GA</b> MAC JAC solenoid plug-in
<b>DF</b> 24 VDC (4.0W)			<b>KA</b> Plug-in wire assy.
			<b>KT</b> Plug-in wire assy. with light
			<b>KD</b> Plug-in wire assy. with rectifier & light & ground

400  
92  
93  
ISO 01  
ISO 02  
ISO 1  
ISO 2  
ISO 3

\* Other options available, see page 311.  
Latching solenoid also available, see page 133.  
Note : AC voltage requires connector with rectifier.  
**Other options available for the 48 series valves, see page 137.**

**TECHNICAL DATA**

<b>Fluid :</b>	Compressed air, vacuum, inert gases
<b>Pressure range :</b>	Internal pilot: 2 pos.: 20 to 120 PSI - 3 pos.: 35 to 120 PSI External pilot: vacuum to 120 PSI
<b>Pilot pressure :</b>	2 position : 20 to 120 PSI - 3 position : 35 to 120 PSI
<b>Lubrication :</b>	Not required, if used select a medium aniline point lubricant (between 180°F and 210°F)
<b>Filtration :</b>	40 µ
<b>Temperature range :</b>	0°F to 120°F (-18°C to +50°C)
<b>Flow :</b>	1/8" side ports: (1.0 C <sub>v</sub> ) - 1/8" bottom ports : (1.1 C <sub>v</sub> )
<b>Coil :</b>	Class A wire (#22 AWG x 18), continuous duty
<b>Voltage range :</b>	-1.5% to +10% of nominal voltage
<b>Power :</b>	1.0 to 4.0 W
<b>Response times :</b> (with 4 W coil)	Energize : 6 ms De-energize : 6 ms

Options :

- BSPP threads • 1/4" O.D. pressed in tube receptacles • Sandwich Flow controls: FC48B-BB
- Sandwich regulator: see "regulators" section

**DIMENSIONS**

Dimensions shown are metric (mm)

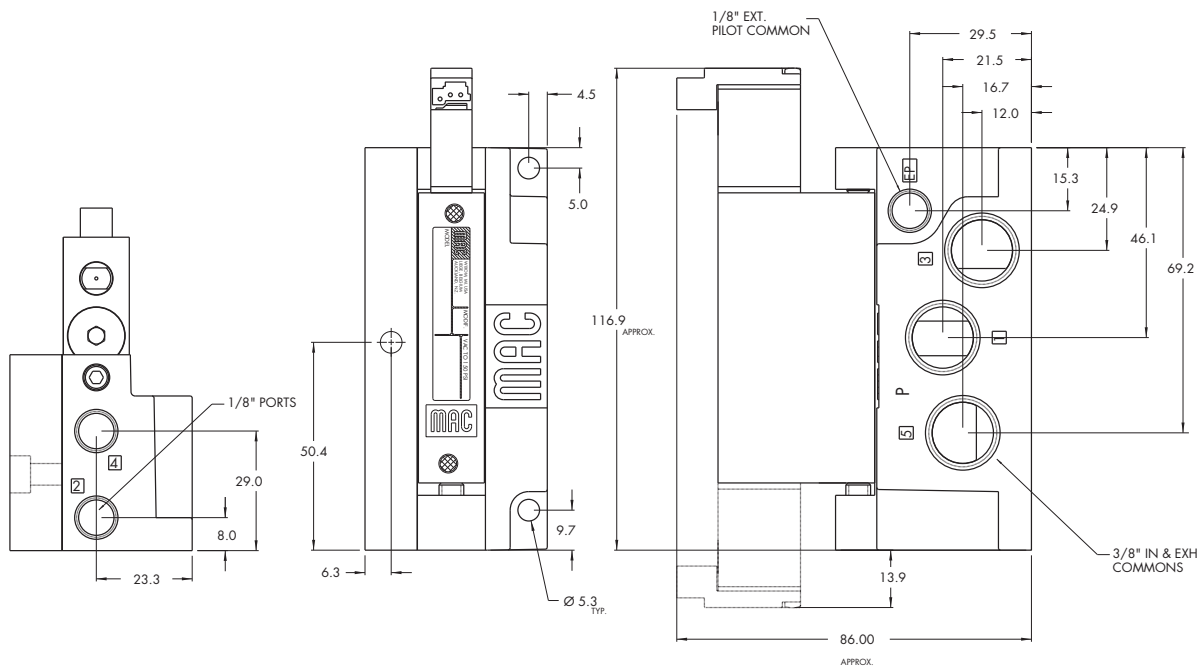





# Direct solenoid and solenoid pilot operated valves

Function	Port size	Flow (Max)	Individual mounting	Series
<b>5/2, 5/3</b>	<b>1/8"</b>	<b>1.1 C<sub>v</sub></b>	Sub-base "plug-in"	

### OPERATIONAL BENEFITS

1. 4-way valve with 4-way integral pilot.
2. 16 mm valve (stacks on 16.5 mm centers).
3. High flow (up to 1.1 C<sub>v</sub>).
4. Fast repeatable response times.
5. Maximum shifting forces in both directions.
6. Long life.



33  
34  
36  
32  
37  
38  
52  
67

### HOW TO ORDER

SINGLE PRESSURE MODELS (LED STANDARD EXCEPT FOR SINGLE SOLENOIDS) - VALVE WITH BASE CODED FOR SIDE PORTS

Port size	Pilot air	5/2 Single solenoid	5/3 Double solenoid	5/3 Closed center	5/3 Open center
<b>Valve less base</b>	Internal	48B-AMA-000-GxxP-xxx	48B-BME-000-GxxP-xST	48B-EME-000-GxxP-xST	48B-FME-000-GxxP-xST
	External	48B-AMD-000-GxxP-xxx	48B-BMH-000-GxxP-xST	48B-EMH-000-GxxP-xST	48B-FMH-000-GxxP-xST
<b>1/8" NPTF</b>	Internal	48B-AMA-AAA-GxxP-xxx	48B-BME-AAC-GxxP-xST	48B-EME-AAC-GxxP-xST	48B-FME-AAC-GxxP-xST
	External	48B-AMD-AAB-GxxP-xxx	48B-BMH-AAD-GxxP-xST	48B-EMH-AAD-GxxP-xST	48B-FMH-AAD-GxxP-xST

69  
44  
46  
42  
47  
48P

DUAL PRESSURE MODELS (LED STANDARD EXCEPT FOR SINGLE SOLENOIDS) - VALVE WITH BASE CODED FOR SIDE PORTS

Port size	Pilot air	5/2 Single solenoid	5/2 Double solenoid	5/3 Pressure center
<b>Valve less base</b>	Internal	Supply #3 port 48B-CMB-000-GxxP-xxx	48B-DMF-000-GxxP-xST	48B-HMF-000-GxxP-xST
	External	Supply #5 port 48B-CMC-000-GxxP-xxx	48B-DMG-000-GxxP-xST	48B-HMG-000-GxxP-xST
<b>1/8" NPTF</b>	Internal	Supply #3 port 48B-CMB-AAA-GxxP-xxx	48B-DMF-AAC-GxxP-xST	48B-HMF-AAC-GxxP-xST
	External	Supply #5 port 48B-CMC-AAA-GxxP-xxx	48B-DMG-AAC-GxxP-xST	48B-HMG-AAC-GxxP-xST

48  
400  
92  
93

STANDARD SOLENOID OPERATOR >

G **XX** P-**XXX**\*

XX	Voltage	X	Manual operator	XX	Electrical connection
AA	120 VAC (2.5W)	1	Non-locking recessed	ST	Double solenoid & 3 position models Base plug-in
DC	24 VDC (1.8W)	2	Locking recessed	SA	Single solenoid models Base plug-in
DD	24 VDC (2.5W)			SJ	Base plug-in with LED light
DF	24 VDC (4.0W)			SS	Base plug-in with rectifier & light & ground

ISO 01  
ISO 02  
ISO 1  
ISO 2  
ISO 3

\* Other options available, see page 311.  
Latching solenoid also available, see page 135.  
Note : AC voltage requires connector with rectifier (For double solenoid consult factory).  
**Other options available for the 48 series valves, see page 138.**

**TECHNICAL DATA**

<b>Fluid :</b>	Compressed air, vacuum, inert gases
<b>Pressure range :</b>	Internal pilot: 2 pos.: 20 to 120 PSI - 3 pos.: 35 to 120 PSI External pilot: vacuum to 120 PSI
<b>Pilot pressure :</b>	2 position : 20 to 120 PSI - 3 position : 35 to 120 PSI
<b>Lubrication :</b>	Not required, if used select a medium aniline point lubricant (between 180°F and 210°F)
<b>Filtration :</b>	40 µ
<b>Temperature range :</b>	0°F to 120°F (-18°C to +50°C)
<b>Flow :</b>	1/8" side ports: (1.0 C <sub>v</sub> ) - 1/8" bottom ports : (1.1 C <sub>v</sub> )
<b>Coil :</b>	Class A continuous duty, #22 AWG x 12 base leads
<b>Voltage range :</b>	-1.5% to +10% of nominal voltage
<b>Power :</b>	1.0 to 4.0 W
<b>Response times : (with 4 W coil)</b>	Energize : 6 ms De-energize : 6 ms

Options :

- BSPP threads • 1/4" O.D. pressed in tube receptacles • Sandwich Flow controls: FC48B-AB
- Sandwich regulator: see "regulators" section

**DIMENSIONS**

Dimensions shown are metric (mm)

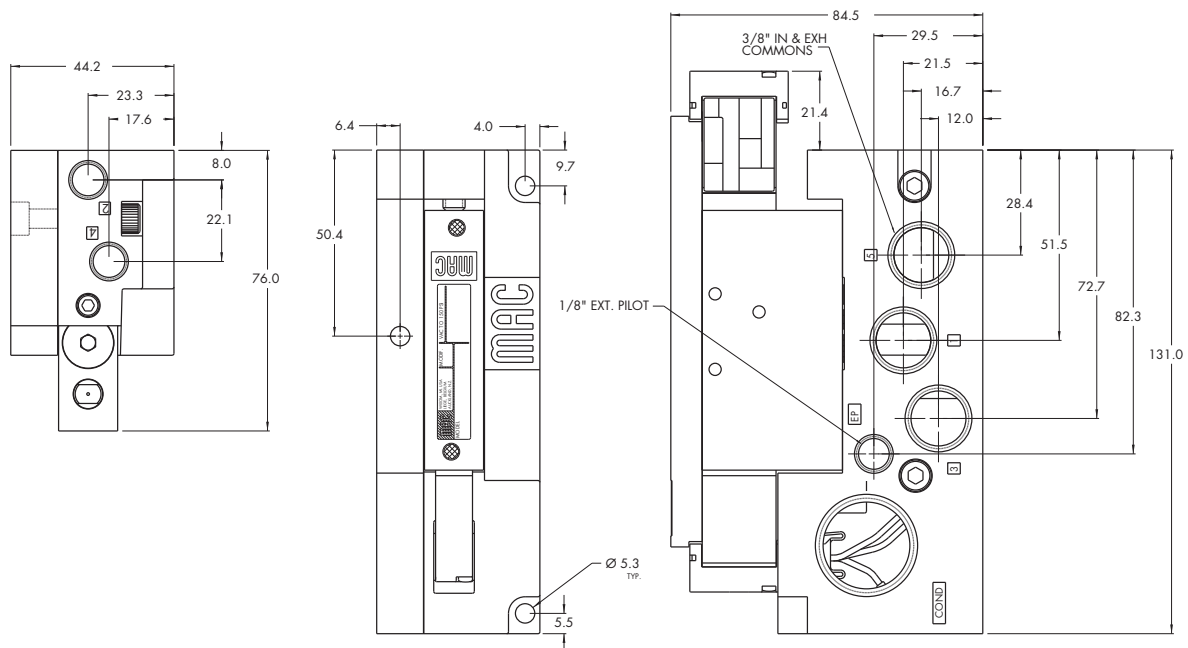

Function	Port size	Flow (Max)	Manifold mounting	Series
<b>5/2, 5/3</b>	<b>1/8"</b>	<b>1.1 C<sub>v</sub></b>	Manifold base non "plug-in"	

### OPERATIONAL BENEFITS

1. 4-way valve with 4-way integral pilot.
2. 16 mm valve (stacks on 16.5 mm centers).
3. High flow (up to 1.1 C<sub>v</sub>).
4. Fast repeatable response times.
5. Maximum shifting forces in both directions.
6. Long life.



33  
34  
36  
32  
37  
38  
52  
67  
69

### HOW TO ORDER

#### SINGLE PRESSURE MODELS (MIDDLE STATION MANIFOLDS WITH SIDE PORTS)

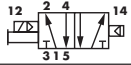
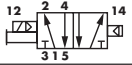
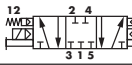
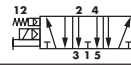
Port size	Pilot air	5/2 Single solenoid	5/2 Double solenoid	5/3 Closed center	5/3 Open center
					
<b>Valve less base</b>	Internal	48B-AMA-000-Gxxx-xxx	48B-BMA-000-Gxxx-xxx	48B-EMA-000-Gxxx-xxx	48B-FMA-000-Gxxx-xxx
	External	48B-AMD-000-Gxxx-xxx	48B-BMD-000-Gxxx-xxx	48B-EMD-000-Gxxx-xxx	48B-FMD-000-Gxxx-xxx
<b>1/8" NPTF</b>	Internal	48B-AMA-AJL-Gxxx-xxx	48B-BMA-AJL-Gxxx-xxx	48B-EMA-AJL-Gxxx-xxx	48B-FMA-AJL-Gxxx-xxx
	External	48B-AMD-AJM-Gxxx-xxx	48B-BMD-AJM-Gxxx-xxx	48B-EMD-AJM-Gxxx-xxx	48B-FMD-AJM-Gxxx-xxx

44  
46  
42  
47  
48P

#### DUAL PRESSURE MODELS (MIDDLE STATION MANIFOLDS WITH SIDE PORTS)

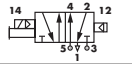
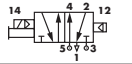
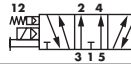
Port size	Pilot air	5/2 Single solenoid	5/2 Double solenoid	5/3 Pressure center
				
<b>Valve less base</b>	Internal	Supply #3 port 48B-CMB-000-Gxxx-xxx	48B-DMB-000-Gxxx-xxx	48B-HMB-000-Gxxx-xxx
	External	Supply #5 port 48B-CMC-000-Gxxx-xxx	48B-DMC-000-Gxxx-xxx	48B-HMC-000-Gxxx-xxx
<b>1/8" NPTF</b>	Internal	Supply #3 port 48B-CMB-AJL-Gxxx-xxx	48B-DMB-AJL-Gxxx-xxx	48B-HMB-AJL-Gxxx-xxx
	External	Supply #5 port 48B-CMC-AJL-Gxxx-xxx	48B-DMC-AJL-Gxxx-xxx	48B-HMC-AJL-Gxxx-xxx

48  
400  
92  
93

#### STANDARD SOLENOID OPERATOR >

G <b>XXX-XXX</b>		X <b>Wire length</b>		X <b>Manual operator</b>		XX <b>Electrical connection</b>	
<b>XX Voltage</b>		<b>X Wire length</b>		<b>X Manual operator</b>		<b>XX Electrical connection</b>	
<b>AA</b>	120 VAC (2.5W)	<b>A</b>	18"	<b>1</b>	Non-locking recessed	<b>BA</b>	Flying leads
<b>DC</b>	24 VDC (1.8W)	<b>B</b>	24"	<b>2</b>	Locking recessed	<b>BT</b>	Flying leads with light
<b>DD</b>	24 VDC (2.5W)	<b>C</b>	36"			<b>GA</b>	MAC JAC solenoid plug-in
<b>DF</b>	24 VDC (4.0W)					<b>KA</b>	Plug-in wire Assy.
						<b>KT</b>	Plug-in wire Assy. with light
						<b>KD</b>	Plug-in wire Assy. with rectifier & light & ground

ISO 01  
ISO 02  
ISO 1  
ISO 2  
ISO 3

\* Other options available, see page 311.  
Latching solenoid also available, see page 133.  
Note : - AC voltage requires connector with rectifier.  
- Manifold assemblies consist of (1) left end manifold, (1) right end manifold, and middle station manifolds (options "J" or "K").  
**Other options available for the 48 series valves, see page 137.**

**TECHNICAL DATA**

<b>Fluid :</b>	Compressed air, vacuum, inert gases
<b>Pressure range :</b>	Internal pilot: 2 pos.: 20 to 120 PSI - 3 pos.: 35 to 120 PSI External pilot: vacuum to 120 PSI
<b>Pilot pressure :</b>	2 position : 20 to 120 PSI - 3 position : 35 to 120 PSI
<b>Lubrication :</b>	Not required, if used select a medium aniline point lubricant (between 180°F and 210°F)
<b>Filtration :</b>	40 μ
<b>Temperature range :</b>	0°F to 120°F (-18°C to +50°C)
<b>Flow :</b>	1/8" side ports: (1.0 C <sub>v</sub> ) - 1/8" bottom ports : (1.1 C <sub>v</sub> )
<b>Coil :</b>	Class A wire (#22 AWG x 18), continuous duty
<b>Voltage range :</b>	-1.5% to +10% of nominal voltage
<b>Power :</b>	1.0 to 4.0 W
<b>Response times : (with 4 W coil)</b>	Energize : 6 ms De-energize : 6 ms

Options :

- BSPP threads • 1/4" O.D. pressed in tube receptacles • Sandwich flow controls: FC48B-BB
- Sandwich regulator: see "regulators" section
- Valve blanking plate: M-48004 • Isolator disk for inlet/exhaust: 28471

**DIMENSIONS**

Dimensions shown are metric (mm)

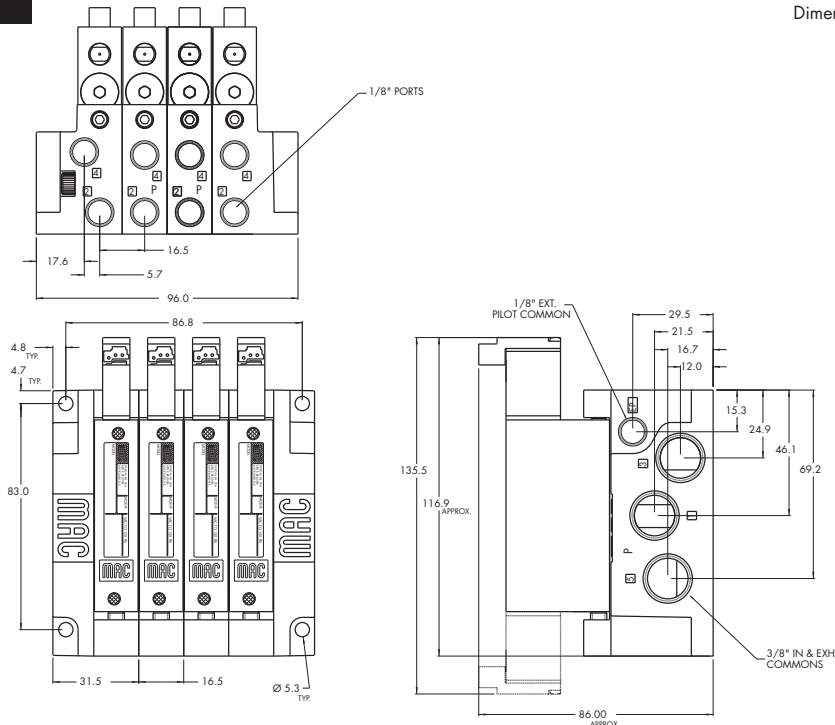



# Direct solenoid and solenoid pilot operated valves

Function	Port size	Flow (Max)	Manifold mounting	Series
<b>5/2, 5/3</b>	<b>1/8"</b>	<b>1.1 C<sub>v</sub></b>	Manifold base "plug-in"	

### OPERATIONAL BENEFITS

1. 4-way valve with 4-way integral pilot.
2. 16 mm valve (stacks on 16.5 mm centers).
3. High flow (up to 1.1 C<sub>v</sub>).
4. Fast repeatable response times.
5. Maximum shifting forces in both directions.
6. Long life.



### HOW TO ORDER

SINGLE PRESSURE MODELS (LED STANDARD EXCEPT FOR SINGLE SOLENOIDS)

Port size	Pilot air	5/2 Single solenoid	5/2 Double solenoid	5/3 Closed center	5/3 Open center
<b>Valve less base</b>	Internal	48B-AMA-000-GxxP-xxx	48B-BME-000-GxxP-xST	48B-EME-000-GxxP-xST	48B-FME-000-GxxP-xST
	External	48B-AMD-000-GxxP-xxx	48B-BMH-000-GxxP-xST	48B-EMH-000-GxxP-xST	48B-FMH-000-GxxP-xST
<b>1/8" NPTF</b>	Internal	48B-AMA-AJA-GxxP-xxx	48B-BME-AJC-GxxP-xST	48B-EME-AJC-GxxP-xST	48B-FME-AJC-GxxP-xST
	External	48B-AMD-AJB-GxxP-xxx	48B-BMH-AJD-GxxP-xST	48B-EMH-AJD-GxxP-xST	48B-FMH-AJD-GxxP-xST

DUAL PRESSURE MODELS (LED STANDARD EXCEPT FOR SINGLE SOLENOIDS)

Port size	Pilot air	5/2 Single solenoid	5/2 Double solenoid	5/3 Pressure center
<b>Valve less base</b>	Internal	Supply #3 port	48B-CMB-000-GxxP-xxx	48B-DMF-000-GxxP-xST
		Supply #5 port	48B-CMC-000-GxxP-xxx	48B-DMG-000-GxxP-xST
	External	48B-CMD-000-GxxP-xxx	48B-DMH-000-GxxP-xST	48B-HMH-000-GxxP-xST
<b>1/8" NPTF</b>	Internal	Supply #3 port	48B-CMB-AJA-GxxP-xxx	48B-DMF-AJC-GxxP-xST
		Supply #5 port	48B-CMC-AJA-GxxP-xxx	48B-DMG-AJC-GxxP-xST
	External	48B-CMD-AJB-GxxP-xxx	48B-DMH-AJD-GxxP-xST	48B-HMH-AJD-GxxP-xST

STANDARD SOLENOID OPERATOR >

G **XX P-XXX\***

Above numbers are middle station manifolds with side ports

XX Voltage	X Manual operator	XX Electrical connection
<b>AA</b> 120 VAC (2.5W)	<b>1</b> Non-locking recessed	<b>ST</b> Base plug-in <i>Double solenoid &amp; 3 position models</i>
<b>DC</b> 24 VDC (1.8W)	<b>2</b> Locking recessed	<b>SA</b> Base plug-in <i>Single solenoid models</i>
<b>DD</b> 24 VDC (2.5W)		<b>SJ</b> Base plug-in with LED light
<b>DF</b> 24 VDC (4.0W)		<b>SS</b> Base plug-in with rectifier & light & ground

\* Other options available, see page 311.

Note : - AC voltage requires connector with rectifier. (For double solenoid consult factory).  
- Manifold assemblies consist of (1) left end manifold, (1) right end manifold, and middle station manifolds (options "J" or "K").

Other options available for the 48 series valves, see page 138.

33  
34  
36  
32  
37  
38  
52  
67  
69  
44  
46  
42  
47  
48P  
48  
400  
92  
93  
ISO 01  
ISO 02  
ISO 1  
ISO 2  
ISO 3

**TECHNICAL DATA**

<b>Fluid :</b>	Compressed air, vacuum, inert gases
<b>Pressure range :</b>	Internal pilot: 2 pos.: 20 to 120 PSI - 3 pos.: 35 to 120 PSI External pilot: vacuum to 120 PSI
<b>Pilot pressure :</b>	2 position : 20 to 120 PSI - 3 position : 35 to 120 PSI
<b>Lubrication :</b>	Not required, if used select a medium aniline point lubricant (between 180°F and 210°F)
<b>Filtration :</b>	40 µ
<b>Temperature range :</b>	0°F to 120°F (-18°C to +50°C)
<b>Flow :</b>	1/8" side ports: (1.0 C <sub>v</sub> ) - 1/8" bottom ports : (1.1 C <sub>v</sub> )
<b>Coil :</b>	Class A wire (#22 AWG x 18), continuous duty
<b>Voltage range :</b>	-1.5% to +10% of nominal voltage
<b>Power :</b>	1.0 to 4.0 W
<b>Response times : (with 4 W coil)</b>	Energize : 6 ms De-energize : 6 ms

Options :

- BSPP threads • 1/4" O.D. pressed in tube receptacles • Sandwich flow controls: FC48B-AB
- Sandwich regulator: see "regulators" section
- Valve blanking plate: M-48004 • Isolator disk for inlet/exhaust: 28471
- Plug-in wire protector: 24180

**DIMENSIONS**

Dimensions shown are metric (mm)

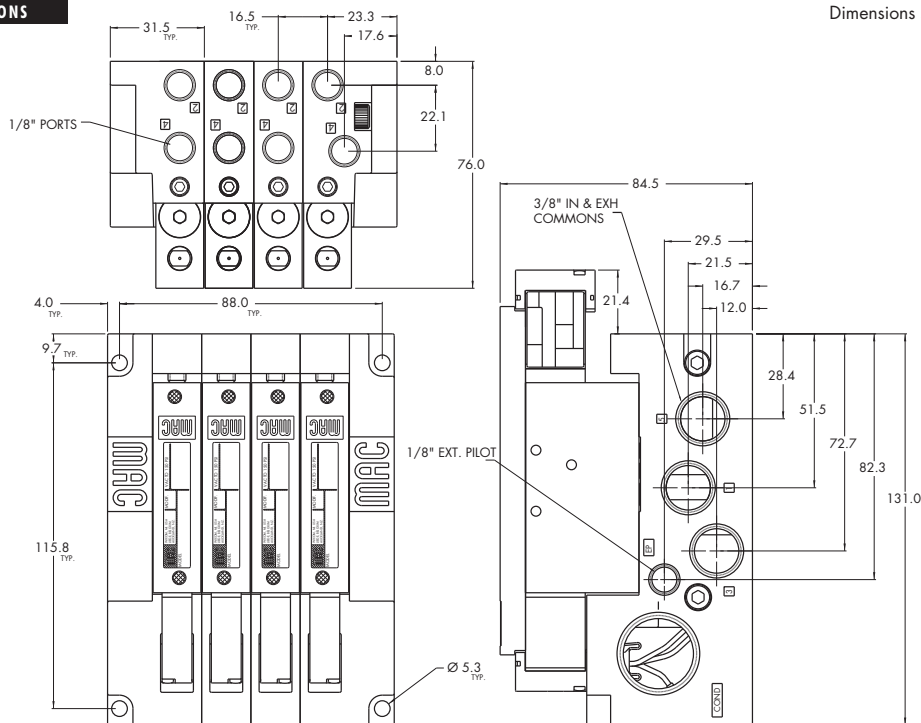

<b>OPTIONS FOR NON PLUG-IN VALVES</b>	<b>33</b>
<b>Base type :</b>	<b>34</b>
<b>Individual base</b>	<b>36</b>
48B-XXX-X <b>A</b> X-Gxxx-xxx	
<b>A</b> Individual base – Side ports	
<b>B</b> Individual base – Bottom ports	
<b>Manifold base</b>	<b>32</b>
48B-XXX-X <b>J</b> X-Gxxx-xxx	
<b>J</b> Manifold base – Side ports	
<b>K</b> Manifold base – Bottom ports	
<b>L</b> Left end manifold base – Side ports	
<b>M</b> Left end manifold base – Bottom ports	
<b>N</b> Right end manifold base – Side ports	
<b>P</b> Right end manifold base – Bottom ports	
<b>Universal spool</b>	<b>37</b>
48B-R <b>X</b> X-XXX-Gxxx-xxx	<b>38</b>
<b>R</b> 2 position single solenoid universal spool	<b>52</b>
<b>S</b> 2 position double solenoid universal spool	<b>67</b>
<b>Base only :</b>	<b>69</b>
48B-000-XXX (i.e. 48B-000-AAL) - Individual base	<b>44</b>
48B-000-XXX (i.e. 48B-000-AJL) - Manifold base	<b>46</b>
<b>Pilot style :</b>	<b>42</b>
48B-X <b>M</b> X-XXX-Gxxx-xxx	<b>47</b>
<b>M</b> Pilot exhaust muffled	<b>48P</b>
<b>P</b> Pilot exhaust piped (# 10-32)	
<b>U</b> Pilot exhaust to main exhaust	
	<b>48</b>
	<b>400</b>
	<b>92</b>
	<b>93</b>
	<b>ISO 01</b>
	<b>ISO 02</b>
	<b>ISO 1</b>
	<b>ISO 2</b>
	<b>ISO 3</b>

**OPTIONS FOR PLUG-IN VALVES**

**Base type :**

**Individual base**

48B-XXX-**AX**-GxxP-xxx

- A** Individual base – Side ports
- B** Individual base – Bottom ports

**Manifold base**

48B-XXX-**XJX**-GxxP-xxx

- J** Manifold base – Side ports
- K** Manifold base – Bottom ports
- L** Left end manifold base – Side ports
- M** Left end manifold base – Bottom ports
- N** Right end manifold base – Side ports
- P** Right end manifold base – Bottom ports

**Universal spool**

48B-**RXX**-XXX-GxxP-xxx

- R** 2 position single solenoid universal spool
- S** 2 position double solenoid universal spool

**Base only :**

48B-000-XXX (i.e. 48B-000-AAA)

- Individual base wired for a single solenoid valve

48B-000-XXX (i.e. 48B-000-AJC)

- Manifold base wired for a double solenoid valve

**For LED with diode (2 & 3 position double solenoid valves)**

48B-**XXJ**-XXX-GxxP-**xST**

- J** Internal pilot single pressure
- K** Internal pilot dual pressure supply from #3 port
- L** Internal pilot dual pressure supply from #5 port
- M** External pilot

**Pilot style :**

48B-**MX**-XXX-GxxP-xxx

- M** Pilot exhaust muffled
- P** Pilot exhaust piped (# 10-32)
- U** Pilot exhaust to main exhaust



Individual mounting

Series

Inline	Sub-base non "plug-in"
--------	------------------------

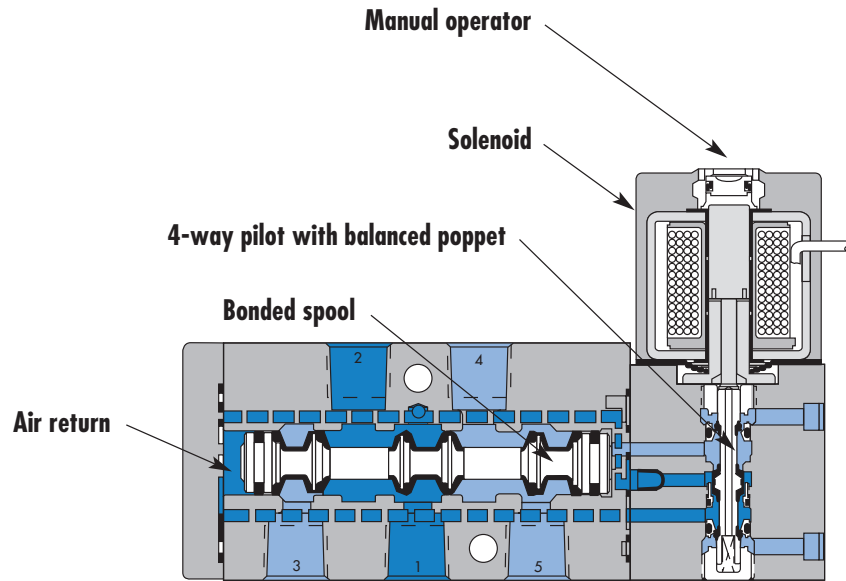

33  
34  
36  
32  
37  
38  
52  
67  
69  
44  
46  
42  
47  
48P  
48

**400**

92

**SERIES FEATURES**

- Patented MACSOLENOID® for fastest possible response times and virtually burn-out proof AC solenoid operation.
- Optional low watt DC solenoids.
- Various manual operators.
- Optional memory spring.
- 2 position or 3 position valve configurations.
- Internal or external pilot.

93

ISO 01

ISO 02

ISO 1

ISO 2

ISO 3

**SPOOL CONFIGURATIONS**

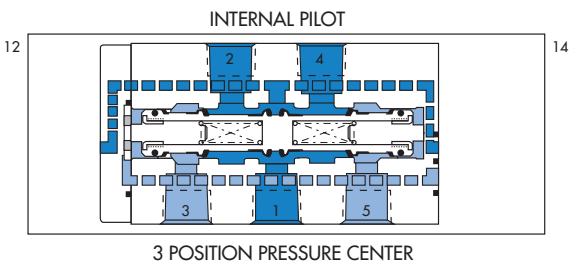
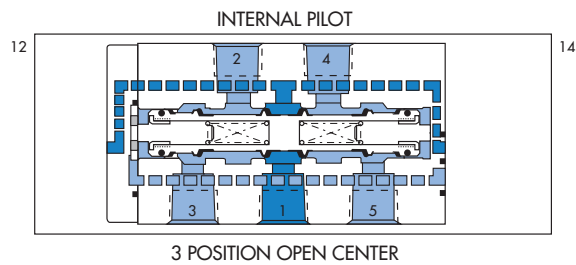
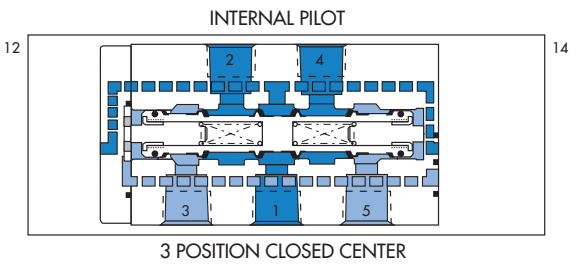
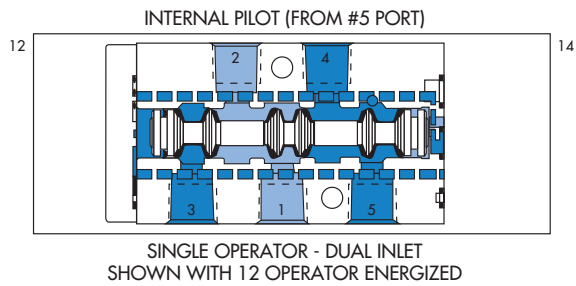
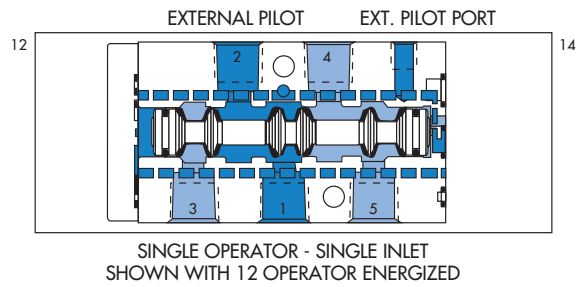
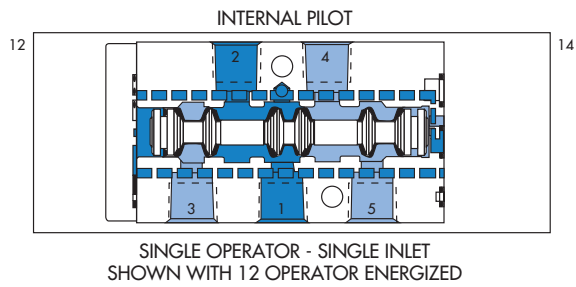



# Direct solenoid and solenoid pilot operated valves

Function	Port size	Flow (Max)	Individual mounting	Series
<b>5/2, 5/3</b>	<b>1/8" - 1/4"</b>	<b>1.0 C<sub>v</sub></b>	Inline	

### OPERATIONAL BENEFITS

1. The 4-way pilot develops maximum shifting forces both ways.
2. Memory spring available.
3. Balanced spool, immune to variations of pressure, also provides high flow.
4. Short stroke with high flow.
5. Bonded spool with minimum friction, shifting in a glass-like finished bore.
6. Wiping effect eliminates sticking.
7. Long service life.



### HOW TO ORDER

#### SINGLE PRESSURE MODELS

Port size	Pilot air	5/2 Single operator	5/2 Double operator	5/3 Closed center	5/3 Open center	5/3 Pressure center
<b>1/8" NPTF</b>	Internal	411A-A0A-XX-XXXX-XXX	421A-A0A-XX-XXXX-XXX	451A-A0A-XX-XXXX-XXX	461A-A0A-XX-XXXX-XXX	471A-A0A-XX-XXXX-XXX
<b>1/4" NPTF</b>	Internal	411A-B0A-XX-XXXX-XXX	421A-B0A-XX-XXXX-XXX	451A-B0A-XX-XXXX-XXX	461A-B0A-XX-XXXX-XXX	471A-B0A-XX-XXXX-XXX
<b>1/8" NPTF</b>	External	411A-A0B-XX-XXXX-XXX	421A-A0B-XX-XXXX-XXX	451A-A0B-XX-XXXX-XXX	461A-A0B-XX-XXXX-XXX	471A-A0B-XX-XXXX-XXX
<b>1/4" NPTF</b>	External	411A-B0B-XX-XXXX-XXX	421A-B0B-XX-XXXX-XXX	451A-B0B-XX-XXXX-XXX	461A-B0B-XX-XXXX-XXX	471A-B0B-XX-XXXX-XXX

#### DUAL PRESSURE MODELS (INTERNAL PILOT – PILOT PRESSURE SUPPLY FROM #5 PORT)

Port size	Pilot air	5/2 Single operator	5/2 Double operator
<b>1/8" NPTF</b>	Internal	431A-A0A-XX-XXXX-XXX	441A-A0A-XX-XXXX-XXX
<b>1/4" NPTF</b>	Internal	431A-B0A-XX-XXXX-XXX	441A-B0A-XX-XXXX-XXX
<b>1/8" NPTF</b>	External	431A-A0B-XX-XXXX-XXX	441A-A0B-XX-XXXX-XXX
<b>1/4" NPTF</b>	External	431A-B0B-XX-XXXX-XXX	441A-B0B-XX-XXXX-XXX

#### SOLENOID OPERATOR >

### DM-D XXX-XXX\*

XX Voltage	X Wire length	X Manual operator	XX Electrical connection
<b>JA</b> 110/50, 120/60 (2.9W)	<b>A</b> 18" (Flying leads)	<b>1</b> Non-locking recessed	<b>KA</b> Square connector
<b>JB</b> 220/50, 240/60 (2.9W)	<b>B</b> 24" (Flying leads)	<b>2</b> Locking recessed	<b>KD</b> Square connector with light
<b>JC</b> 24/60 (2.9W)	<b>J</b> Connector		<b>JB</b> Rectangular connector
<b>FB</b> 24 VDC (1.8W)			<b>JD</b> Rectangular connector with light
<b>DA</b> 24 VDC (5.4W)			<b>BA</b> Flying leads
<b>DF</b> 24 VDC (12.7W)			

#### SOLENOID OPERATOR >

### GM-G XXX-XXX\*\*

XX Voltage	X Wire length	X Manual operator	XX Electrical connection
<b>DC</b> 24VDC (1.8W)	<b>A</b> 18"	<b>1</b> Non-locking recessed	<b>BA</b> Flying leads
<b>DD</b> 24VDC (2.5W)	<b>B</b> 24"	<b>2</b> Locking recessed	<b>BT</b> Flying leads with light
<b>DF</b> 24VDC (4.0W)	<b>C</b> 36"		<b>KA</b> Plug-in wire assy.
			<b>KT</b> Plug-in wire assy. with light

\* Other options available, see page 309.  
 \*\* Other options available, see page 313.

33  
34  
36  
32  
37  
38  
52  
67  
69  
44  
46  
42  
47  
48P  
48  
400  
92  
93  
ISO 01  
ISO 02  
ISO 1  
ISO 2  
ISO 3

**TECHNICAL DATA**

<b>Fluid :</b>	Compressed air, vacuum, inert gases
<b>Pressure range :</b>	Internal pilot – 2 pos. : 20 to 120 PSI (with memory spring: 30 to 120 PSI) 3 pos.: 35 to 120 PSI External pilot : vacuum to 120 PSI
<b>Pilot pressure :</b>	2 position: 20 to 120 PSI (with memory spring: 30 to 120 PSI) 3 position: 35 to 120 PSI
<b>Lubrication :</b>	Not required, if used select a medium aniline point lubricant (between 180°F and 210°F)
<b>Filtration :</b>	40 µ
<b>Temperature range :</b>	0°F to 120°F (-18°C to +50°C)
<b>Flow :</b>	1.0 C <sub>v</sub>
<b>Coil :</b>	Class A continuous duty, #22 AWG x 12 leads wires
<b>Voltage range :</b>	-1.5% to +10% of nominal voltage
<b>Protection :</b>	Consult factory
<b>Power :</b>	~Inrush : 10.9 VA    Holding : 7.7 VA = 1.8 to 12.7 W
<b>Response times :</b>	24 V=/5.4W    Energize : 7.3 ms    De-energize : 5.3 ms 120/60    Energize : 8-12 ms    De-energize : 7-11 ms

Options :

- BSPP threads • Namur interface (specify mod. 1080 after model)

**411A-A0A-XX-XXX-XXX**

- Dual pressure models, replace by **C** for pilot supply from #3 port
- For memory spring, replace by **4** (single operator models only)
- Replace by **8** for 3 position dual pressure, pressure center

Spare parts :

- DM pilot body pressure seal: 16542 • DM pilot spacer plate: 24168-01.

**DIMENSIONS**

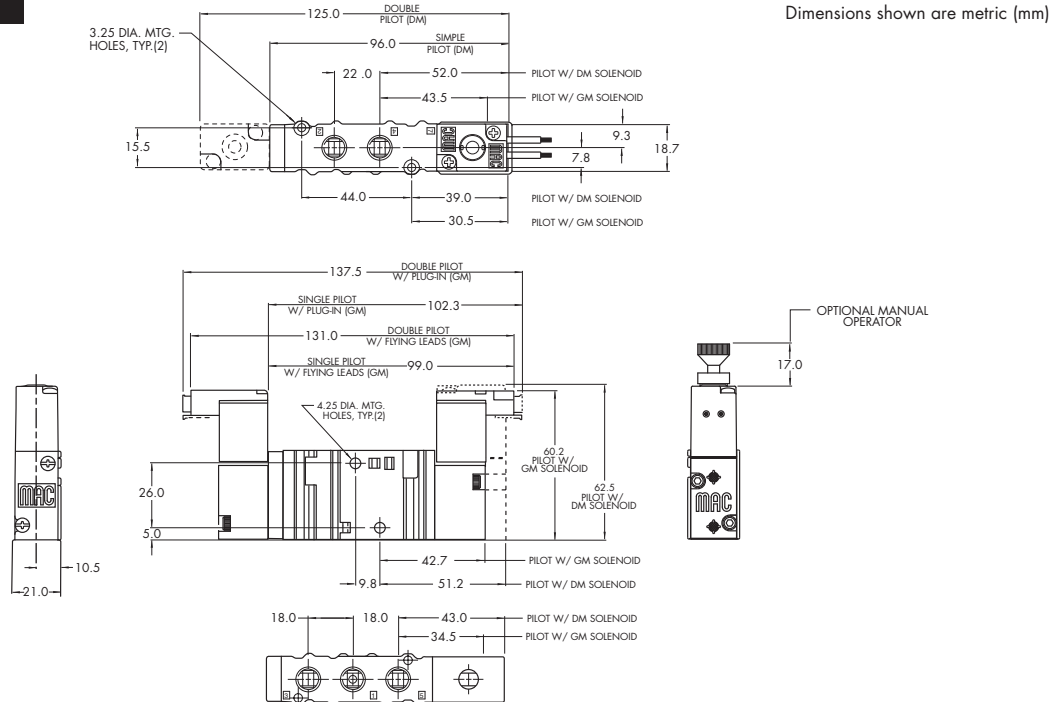

Function	Port size	Flow (Max)	Individual mounting	Series
<b>5/2, 5/3</b>	<b>1/8" - 1/4"</b>	<b>1.0 C<sub>v</sub></b>	Sub-base non "plug-in"	

### OPERATIONAL BENEFITS

1. The 4-way pilot develops maximum shifting forces both ways.
2. Memory spring available.
3. Balanced spool, immune to variations of pressure, also provides high flow.
4. Short stroke with high flow.
5. Bonded spool with minimum friction, shifting in a glass-like finished bore.
6. Wiping effect eliminates sticking.
7. Long service life.



33  
34  
36  
32  
37  
38  
52  
67  
69  
44  
46  
42  
47  
48P

### HOW TO ORDER

#### SINGLE PRESSURE MODELS

Port size	Pilot air	5/2 Single operator	5/2 Double operator	5/3 Closed center	5/3 Open center	5/3 Pressure center
<b>Valve only</b>	Internal	413A-00A-XX-XXXX-XXX	423A-00A-XX-XXXX-XXX	453A-00A-XX-XXXX-XXX	463A-00A-XX-XXXX-XXX	473A-00A-XX-XXXX-XXX
	External	413A-00D-XX-XXXX-XXX	423A-00D-XX-XXXX-XXX	453A-00D-XX-XXXX-XXX	463A-00D-XX-XXXX-XXX	473A-00D-XX-XXXX-XXX
<b>1/8" NPTF</b>	Internal	413A-AAA-XX-XXXX-XXX	423A-AAA-XX-XXXX-XXX	453A-AAA-XX-XXXX-XXX	463A-AAA-XX-XXXX-XXX	473A-AAA-XX-XXXX-XXX
<b>1/4" NPTF</b>	Internal	413A-BAA-XX-XXXX-XXX	423A-BAA-XX-XXXX-XXX	453A-BAA-XX-XXXX-XXX	463A-BAA-XX-XXXX-XXX	473A-BAA-XX-XXXX-XXX
<b>1/8" NPTF</b>	External	413A-AAD-XX-XXXX-XXX	423A-AAD-XX-XXXX-XXX	453A-AAD-XX-XXXX-XXX	463A-AAD-XX-XXXX-XXX	473A-AAD-XX-XXXX-XXX
<b>1/4" NPTF</b>	External	413A-BAD-XX-XXXX-XXX	423A-BAD-XX-XXXX-XXX	453A-BAD-XX-XXXX-XXX	463A-BAD-XX-XXXX-XXX	473A-BAD-XX-XXXX-XXX

#### DUAL PRESSURE MODELS (INTERNAL PILOT – PILOT PRESSURE SUPPLY FROM #5 PORT)

Port size	Pilot air	5/2 Single operator	5/2 Double operator
<b>Valve only</b>	Internal	433A-00A-XX-XXXX-XXX	443A-00A-XX-XXXX-XXX
	External	433A-00D-XX-XXXX-XXX	443A-00D-XX-XXXX-XXX
<b>1/8" NPTF</b>	Internal	433A-AAA-XX-XXXX-XXX	443A-AAA-XX-XXXX-XXX
<b>1/4" NPTF</b>	Internal	433A-BAA-XX-XXXX-XXX	443A-BAA-XX-XXXX-XXX
<b>1/8" NPTF</b>	External	433A-AAD-XX-XXXX-XXX	443A-AAD-XX-XXXX-XXX
<b>1/4" NPTF</b>	External	433A-BAD-XX-XXXX-XXX	443A-BAD-XX-XXXX-XXX

48  
400  
92  
93

#### SOLENOID OPERATOR >

### DM-D XXX-XXX\*

XX Voltage	X Wire length	X Manual operator	XX Electrical connection
<b>JA</b> 110/50, 120/60 (2.9W)	<b>A</b> 18" (Flying leads)	<b>1</b> Non-locking recessed	<b>KA</b> Square connector
<b>JB</b> 220/50, 240/60 (2.9W)	<b>B</b> 24" (Flying leads)	<b>2</b> Locking recessed	<b>KD</b> Square connector with light
<b>JC</b> 24/60 (2.9W)	<b>J</b> Connector		<b>JB</b> Rectangular connector
<b>FB</b> 24 VDC (1.8W)			<b>JD</b> Rectangular connector with light
<b>DA</b> 24 VDC (5.4W)			<b>BA</b> Flying leads
<b>DF</b> 24 VDC (12.7W)			

ISO 01  
ISO 02  
ISO 1  
ISO 2  
ISO 3

#### SOLENOID OPERATOR >

### GM-G XXX-XXX\*\*

XX Voltage	X Wire length	X Manual operator	XX Electrical connection
<b>DC</b> 24VDC (1.8W)	<b>A</b> 18"	<b>1</b> Non-locking recessed	<b>BA</b> Flying leads
<b>DD</b> 24VDC (2.5W)	<b>B</b> 24"	<b>2</b> Locking recessed	<b>BT</b> Flying leads with light
<b>DF</b> 24VDC (4.0W)	<b>C</b> 36"		<b>KA</b> Plug-in wire assy.
			<b>KT</b> Plug-in wire assy. with light

\* Other options available, see page 309.  
\*\* Other options available, see page 313.

**TECHNICAL DATA**

<b>Fluid :</b>	Compressed air, vacuum, inert gases
<b>Pressure range :</b>	Internal pilot – 2 pos. : 20 to 120 PSI (with memory spring: 30 to 120 PSI) 3 pos.: 35 to 120 PSI External pilot : vacuum to 120 PSI
<b>Pilot pressure :</b>	2 position: 20 to 120 PSI (with memory spring: 30 to 120 PSI) 3 position: 35 to 120 PSI
<b>Lubrication :</b>	Not required, if used select a medium aniline point lubricant (between 180°F and 210°F)
<b>Filtration :</b>	40 µ
<b>Temperature range :</b>	0°F to 120°F (-18°C to +50°C)
<b>Flow :</b>	1.0 C <sub>v</sub>
<b>Coil :</b>	Class A continuous duty, #22 AWG x 12 leads wires
<b>Voltage range :</b>	-1.5% to +10% of nominal voltage
<b>Protection :</b>	Consult factory
<b>Power :</b>	~Inrush : 10.9 VA Holding : 7.7 VA = 1.8 to 12.7 W
<b>Response times :</b>	24 V=/5.4W Energize : 7.3 ms De-energize : 5.3 ms 120/60 Energize : 8-12 ms De-energize : 7-11 ms

Options :

- BSPP threads

413A-AAA-XX-XXXX-XXX

- Dual pressure models, replace by **C** for pilot supply from #3 port
- For flow control, replace by **B**
- For memory spring, replace by **6**

Base only :

400A-XXX  
(i.e. 400A-AAA)

Spare parts :

- Body to base seal: 16525 • Flow control assembly: N-04001 • Body mounting screws (x2): 35043.

**DIMENSIONS**

Dimensions shown are metric (mm)

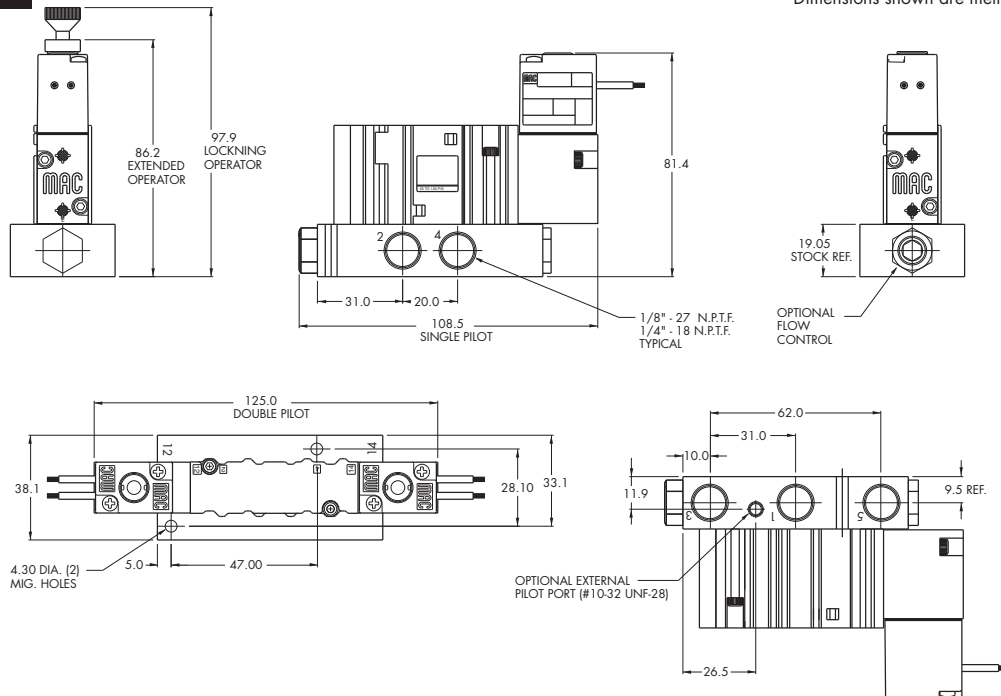

# Direct solenoid and solenoid pilot operated valves

## Individual mounting

Sub-base non "plug-in"	Sub-base "plug-in"
------------------------	--------------------

Series

## Manifold mounting

Sub-base non "plug-in"	Sub-base "plug-in"
------------------------	--------------------

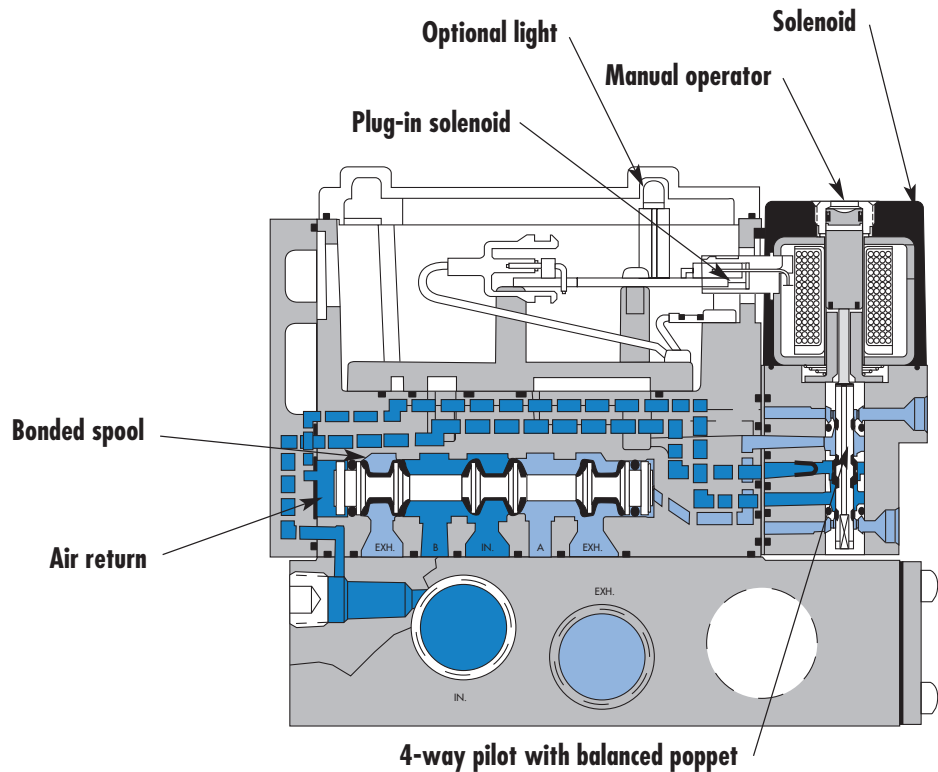

### SERIES FEATURES

- Patented MACSOLENOID® for fastest possible response times and virtually burn-out proof AC solenoid operation.
- Optional low watt DC solenoids.
- Optional memory spring.
- Plug-in design of valves and bases for ease of maintenance.
- 2 position or 3 position valve configurations.

33

34

36

32

37

38

52

67

69

44

46

42

47

48P

48

400

92

48

400

92

92

92

93

93

ISO 01

ISO 02

ISO 1

ISO 2

ISO 3

**SPOOL CONFIGURATIONS**

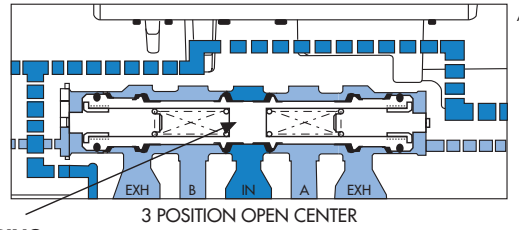
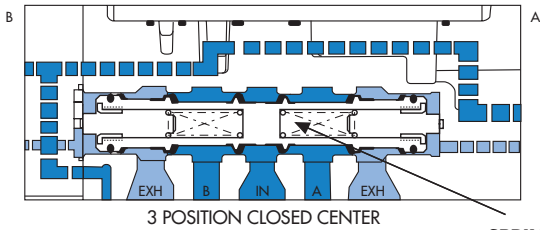
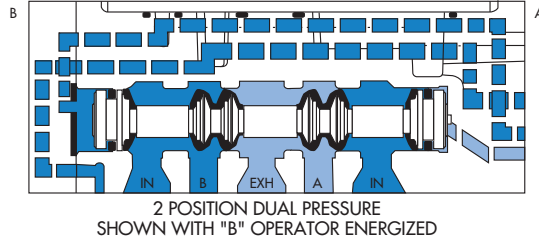
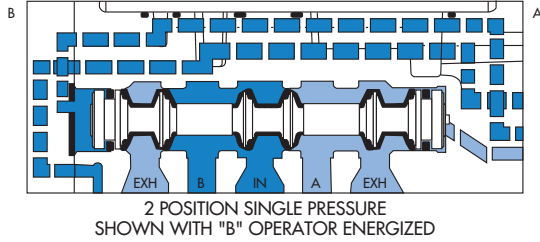

**SPRING CENTERING**

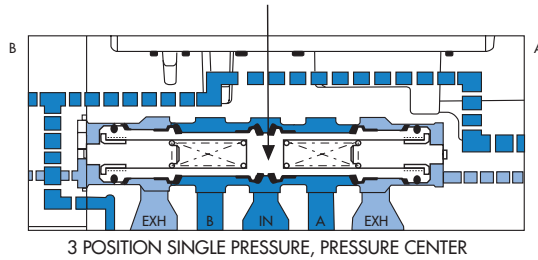

**REGULATOR CONFIGURATIONS**

**SINGLE REGULATOR - SINGLE PRESSURE**

Pressure supplied to the individual or manifold base passes through the regulator. Regulated pressure is supplied to the pressure path of the valve.

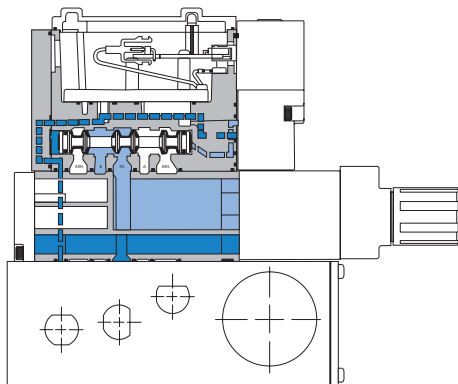

**MANIFOLD WITH REGULATOR - SINGLE PRESSURE**

**Note:** For both single and dual pressure, air supply to the pilot system is never regulated.

**DUAL REGULATOR - DUAL PRESSURE**

Pressure supplied from each regulator is divided in the block. Regulated pressure from "A" regulator supplies cylinder port "A". Regulated pressure from "B" regulator supplies cylinder port "B". Dual pressure regulators require dual pressure spool in valve.

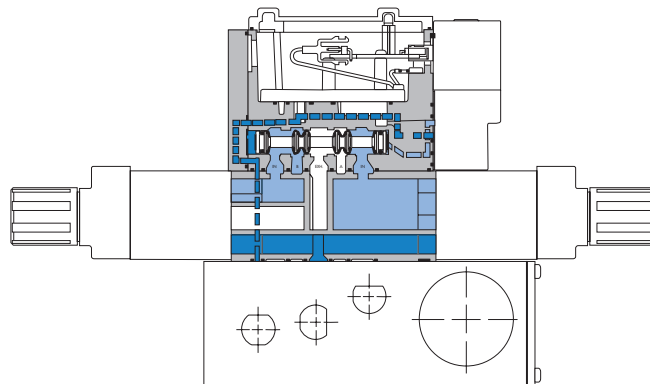

**MANIFOLD WITH REGULATOR - DUAL PRESSURE**





# Direct solenoid and solenoid pilot operated valves

Function	Port size	Flow (Max)	Individual mounting	Series
<b>5/2, 5/3</b>	<b>1/8" - 1/4" - 3/8"</b>	<b>1.2 C<sub>v</sub></b>	Sub-base non "plug-in"	

### OPERATIONAL BENEFITS

1. The 4-way pilot develops maximum shifting forces both ways.
2. Memory spring available.
3. Balanced spool, immune to variations of pressure, also provides high flow.
4. Short stroke with high flow.
5. Bonded seal spool with minimum friction, shifting in a glass-like finished bore.
6. Pilot with balanced poppet, high flow; short and consistent response times.



### HOW TO ORDER

#### SINGLE PRESSURE MODELS

Port size	Pilot air	5/2 Single operator	5/2 Double operator	5/3 Closed center	5/3 Open center	5/3 Pressure center
<b>Valve less base</b>		92B-ABA-000-DM-Dxxx-xxx	92B-BBA-000-DM-Dxxx-xxx	92B-EBA-000-DM-Dxxx-xxx	92B-FBA-000-DM-Dxxx-xxx	92B-GBA-000-DM-Dxxx-xxx
<b>1/8" NPTF</b>		92B-ABA-AAG-DM-Dxxx-xxx	92B-BBA-AAG-DM-Dxxx-xxx	92B-EBA-AAG-DM-Dxxx-xxx	92B-FBA-AAG-DM-Dxxx-xxx	92B-GBA-AAG-DM-Dxxx-xxx
<b>1/4" NPTF</b>	Internal	92B-ABA-BAG-DM-Dxxx-xxx	92B-BBA-BAG-DM-Dxxx-xxx	92B-EBA-BAG-DM-Dxxx-xxx	92B-FBA-BAG-DM-Dxxx-xxx	92B-GBA-BAG-DM-Dxxx-xxx
<b>3/8" NPTF</b>		92B-ABA-CAG-DM-Dxxx-xxx	92B-BBA-CAG-DM-Dxxx-xxx	92B-EBA-CAG-DM-Dxxx-xxx	92B-FBA-CAG-DM-Dxxx-xxx	92B-GBA-CAG-DM-Dxxx-xxx
<b>1/8" NPTF</b>		92B-ABA-AAH-DM-Dxxx-xxx	92B-BBA-AAH-DM-Dxxx-xxx	92B-EBA-AAH-DM-Dxxx-xxx	92B-FBA-AAH-DM-Dxxx-xxx	92B-GBA-AAH-DM-Dxxx-xxx
<b>1/4" NPTF</b>	External	92B-ABA-BAH-DM-Dxxx-xxx	92B-BBA-BAH-DM-Dxxx-xxx	92B-EBA-BAH-DM-Dxxx-xxx	92B-FBA-BAH-DM-Dxxx-xxx	92B-GBA-BAH-DM-Dxxx-xxx
<b>3/8" NPTF</b>		92B-ABA-CAH-DM-Dxxx-xxx	92B-BBA-CAH-DM-Dxxx-xxx	92B-EBA-CAH-DM-Dxxx-xxx	92B-FBA-CAH-DM-Dxxx-xxx	92B-GBA-CAH-DM-Dxxx-xxx

#### DUAL PRESSURE MODELS (REQUIRE SANDWICH REGULATOR – SEE "REGULATORS" SECTION)

Port size	Pilot air	5/2 Single operator	5/2 Double operator
<b>Valve less base</b>		92B-CBA-000-DM-Dxxx-xxx	92B-DBA-000-DM-Dxxx-xxx
<b>1/8" NPTF</b>		92B-CBA-AAG-DM-Dxxx-xxx	92B-DBA-AAG-DM-Dxxx-xxx
<b>1/4" NPTF</b>	Internal	92B-CBA-BAG-DM-Dxxx-xxx	92B-DBA-BAG-DM-Dxxx-xxx
<b>3/8" NPTF</b>		92B-CBA-CAG-DM-Dxxx-xxx	92B-DBA-CAG-DM-Dxxx-xxx
<b>1/8" NPTF</b>		92B-CBA-AAH-DM-Dxxx-xxx	92B-DBA-AAH-DM-Dxxx-xxx
<b>1/4" NPTF</b>	External	92B-CBA-BAH-DM-Dxxx-xxx	92B-DBA-BAH-DM-Dxxx-xxx
<b>3/8" NPTF</b>		92B-CBA-CAH-DM-Dxxx-xxx	92B-DBA-CAH-DM-Dxxx-xxx

#### SOLENOID OPERATOR >

DM-D **XXX-XXX**\*

Above models are shown with side ports.

XX Voltage	X Wire length	X Manual operator	XX Electrical connection
<b>JA</b> 110 /50, 120/60 (2.9W)	<b>A</b> 18" (Flying leads)	<b>1</b> Non-locking recessed	<b>BM</b> Flying leads
<b>JB</b> 220/50, 240/60 (2.9W)	<b>B</b> 24" (Flying leads)	<b>2</b> Locking recessed	<b>BN</b> Flying leads with diode
<b>JC</b> 24/60 (2.9W)	<b>J</b> Connector		<b>BP</b> Flying leads with M.O.V.
<b>FB</b> 24 VDC (1.8W)			<b>BG</b> Flying leads with ground
<b>DA</b> 24 VDC (5.4W)			<b>JB</b> Rectangular connector
<b>DF</b> 24 VDC (12.7W)			<b>JD</b> Rectangular connector with light
			<b>KA</b> Square connector

\* Other options available, see page 309.  
Other options available for the 92 series valves, see page 155.

33  
34  
36  
32  
37  
38  
52  
67  
69  
44  
46  
42  
47  
48P  
48  
400  
92  
93  
ISO 01  
ISO 02  
ISO 1  
ISO 2  
ISO 3

**TECHNICAL DATA**

<b>Fluid :</b>	Compressed air, vacuum, inert gases
<b>Pressure range :</b>	Internal pilot : 20 to 120 PSI      3 position : 35 to 120 PSI External pilot : vacuum to 120 PSI      3 position : 35 to 120 PSI
<b>Lubrication :</b>	Not required, if used select a medium aniline point lubricant (between 180°F and 210°F)
<b>Filtration :</b>	40 µ
<b>Temperature range :</b>	0°F to 120°F (-18°C to +50°C)
<b>Flow :</b>	1/8": (1.0 C <sub>v</sub> ) – 1/4": (1.1 C <sub>v</sub> ) – 3/8": (1.2 C <sub>v</sub> )
<b>Coil :</b>	Class A continuous duty, #22 AWG x 18 lead wire
<b>Voltage range :</b>	-15% to +10% of nominal voltage
<b>Protection :</b>	Consult factory
<b>Power :</b>	~Inrush 7.6 VA      Holding : 4.8 VA = 1.8 to 12.7 W
<b>Response times :</b>	24V=5.4W      Energize : 8 ms      De-energize : 7 ms 120/60      Energize : 7-13 ms      De-energize : 12-20 ms

- Options :      • BSPP threads • Sandwich flow control: FC92B-CA
- Spare parts :      • Pilot valve DM-Dxxx-xxx • Valve blanking plate: M-92002  
                             • Pressure seal between valve and base : 16543. • Mounting screws valve to base (X2) : 35050.

**DIMENSIONS**

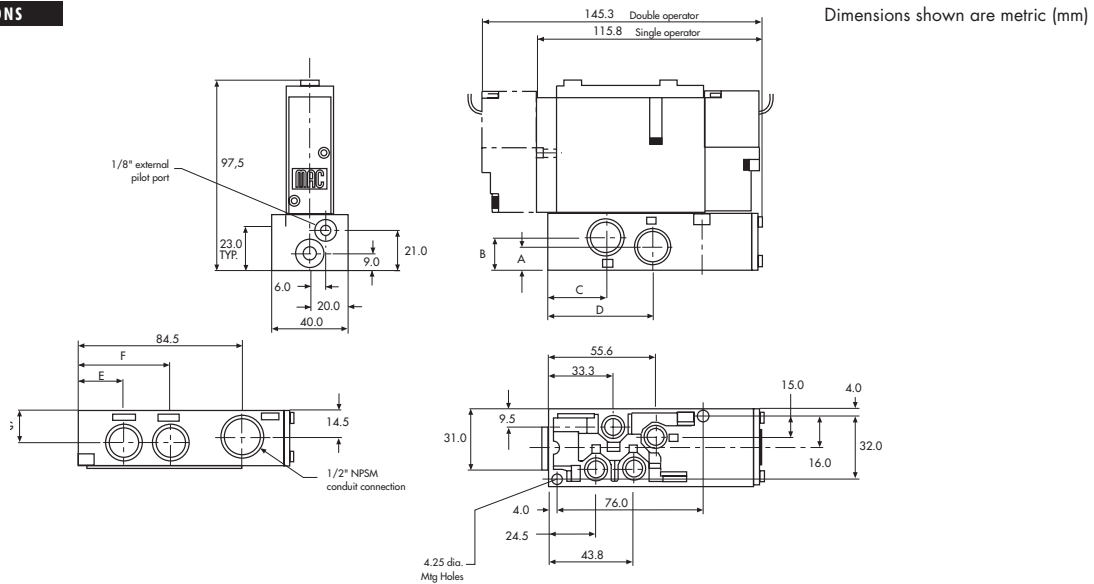



# Direct solenoid and solenoid pilot operated valves

Function	Port size	Flow (Max)	Individual mounting	Series
<b>5/2, 5/3</b>	<b>1/8" - 1/4" - 3/8"</b>	<b>1.2 C<sub>v</sub></b>	Sub-base "plug-in"	

### OPERATIONAL BENEFITS

1. The 4-way pilot develops maximum shifting forces both ways.
2. Memory spring available.
3. Balanced spool, immune to variations of pressure, also provides high flow.
4. Short stroke with high flow.
5. Bonded seal spool with minimum friction, shifting in a glass-like finished bore.
6. Pilot with balanced poppet, high flow; short and consistent response times.



33  
34  
36  
32  
37  
38  
52  
67  
69  
44

### HOW TO ORDER

#### SINGLE PRESSURE MODELS

Port size	Pilot air	5/2 Single operator	5/2 Double operator	5/3 Closed center	5/3 Open center	5/3 Pressure center
<b>Valve less base</b>		92B-AAA-000-DM-DxxP-xxx	92B-BAA-000-DM-DxxP-xxx	92B-EAA-000-DM-DxxP-xxx	92B-FAA-000-DM-DxxP-xxx	92B-GAA-000-DM-DxxP-xxx
<b>1/8"</b>	Internal	92B-AAA-AAA-DM-DxxP-xxx	92B-BAA-AAA-DM-DxxP-xxx	92B-EAA-AAA-DM-DxxP-xxx	92B-FAA-AAA-DM-DxxP-xxx	92B-GAA-AAA-DM-DxxP-xxx
<b>1/4"</b>		92B-AAA-BAA-DM-DxxP-xxx	92B-BAA-BAA-DM-DxxP-xxx	92B-EAA-BAA-DM-DxxP-xxx	92B-FAA-BAA-DM-DxxP-xxx	92B-GAA-BAA-DM-DxxP-xxx
<b>3/8"</b>		92B-AAA-CAA-DM-DxxP-xxx	92B-BAA-CAA-DM-DxxP-xxx	92B-EAA-CAA-DM-DxxP-xxx	92B-FAA-CAA-DM-DxxP-xxx	92B-GAA-CAA-DM-DxxP-xxx
<b>1/8"</b>	External	92B-AAA-AAD-DM-DxxP-xxx	92B-BAA-AAD-DM-DxxP-xxx	92B-EAA-AAD-DM-DxxP-xxx	92B-FAA-AAD-DM-DxxP-xxx	92B-GAA-AAD-DM-DxxP-xxx
<b>1/4"</b>		92B-AAA-BAD-DM-DxxP-xxx	92B-BAA-BAD-DM-DxxP-xxx	92B-EAA-BAD-DM-DxxP-xxx	92B-FAA-BAD-DM-DxxP-xxx	92B-GAA-BAD-DM-DxxP-xxx
<b>3/8"</b>		92B-AAA-CAD-DM-DxxP-xxx	92B-BAA-CAD-DM-DxxP-xxx	92B-EAA-CAD-DM-DxxP-xxx	92B-FAA-CAD-DM-DxxP-xxx	92B-GAA-CAD-DM-DxxP-xxx

46  
42  
47  
48P  
48

#### DUAL PRESSURE MODELS (REQUIRE SANDWICH REGULATOR – SEE "REGULATORS" SECTION)

Port size	Pilot air	5/2 Single operator	5/2 Double operator
<b>Valve less base</b>		92B-CAA-000-DM-DxxP-xxx	92B-DAA-000-DM-DxxP-xxx
<b>1/8"</b>	Internal	92B-CAA-AAA-DM-DxxP-xxx	92B-DAA-AAA-DM-DxxP-xxx
<b>1/4"</b>		92B-CAA-BAA-DM-DxxP-xxx	92B-DAA-BAA-DM-DxxP-xxx
<b>3/8"</b>		92B-CAA-CAA-DM-DxxP-xxx	92B-DAA-CAA-DM-DxxP-xxx
<b>1/8"</b>	External	92B-CAA-AAD-DM-DxxP-xxx	92B-DAA-AAD-DM-DxxP-xxx
<b>1/4"</b>		92B-CAA-BAD-DM-DxxP-xxx	92B-DAA-BAD-DM-DxxP-xxx
<b>3/8"</b>		92B-CAA-CAD-DM-DxxP-xxx	92B-DAA-CAD-DM-DxxP-xxx

400  
92  
93

ISO 01  
ISO 02  
ISO 1  
ISO 2  
ISO 3

#### SOLENOID OPERATOR >

### DM-D XX P-XXX\*

Above models are shown with side ports.

XX Voltage	X Manual operator	XX Electrical connection
<b>JA</b> 110/50, 120/60 (2.9W)	<b>1</b> Non-locking recessed	<b>DM</b> Plug-in
<b>JB</b> 220/50, 240/60 (2.9W)	<b>2</b> Locking recessed	<b>DN</b> Plug-in with diode
<b>JC</b> 24/60 (2.9W)		<b>DP</b> Plug-in with M.O.V.
<b>FB</b> 24 VDC (1.8W)		<b>DG</b> Plug-in with ground
<b>DA</b> 24 VDC (5.4W)		<b>DJ</b> Plug-in with M.O.V. & ground
<b>DF</b> 24 VDC (12.7W)		<b>DH</b> Plug-in with diode & ground

\* Other options available, see page 309.  
Note: Ground required for 30 Volts or higher.  
Other options available for the 92 series valves, see page 156.

**TECHNICAL DATA**

<b>Fluid :</b>	Compressed air, vacuum, inert gases
<b>Pressure range :</b>	Internal pilot : 20 to 120 PSI      3 position : 35 to 120 PSI External pilot : vacuum to 120 PSI      3 position : 35 to 120 PSI
<b>Lubrication :</b>	Not required, if used select a medium aniline point lubricant (between 180°F and 210°F)
<b>Filtration :</b>	40 µ
<b>Temperature range :</b>	0°F to 120°F (-18°C to +50°C)
<b>Flow :</b>	1/8": (1.0 C <sub>v</sub> ) – 1/4": (1.1 C <sub>v</sub> ) – 3/8": (1.2 C <sub>v</sub> )
<b>Coil :</b>	Class A continuous duty, #22 AWG x 18 lead wire
<b>Voltage range :</b>	-1.5% to +10% of nominal voltage
<b>Protection :</b>	Consult factory
<b>Power :</b>	~Inrush 7.6 VA      Holding : 4.8 VA = 1.8 to 12.7 W
<b>Response times :</b>	24V=/5.4W      Energize : 8 ms      De-energize : 7 ms 120/60      Energize : 7-13 ms      De-energize : 12-20 ms

- Options :      • BSPP threads • Sandwich flow control: FC92B-AA (sgl. operator), FC92B-BA (dbl. operator)
- Spare parts :      • Pilot valve DM-DxxP-xxx • Valve blanking plate: M-92002  
                             • Pressure seal between valve and base : 16543. • Mounting screws valve to base (X2) : 35050.

**DIMENSIONS**

Dimensions shown are metric (mm)

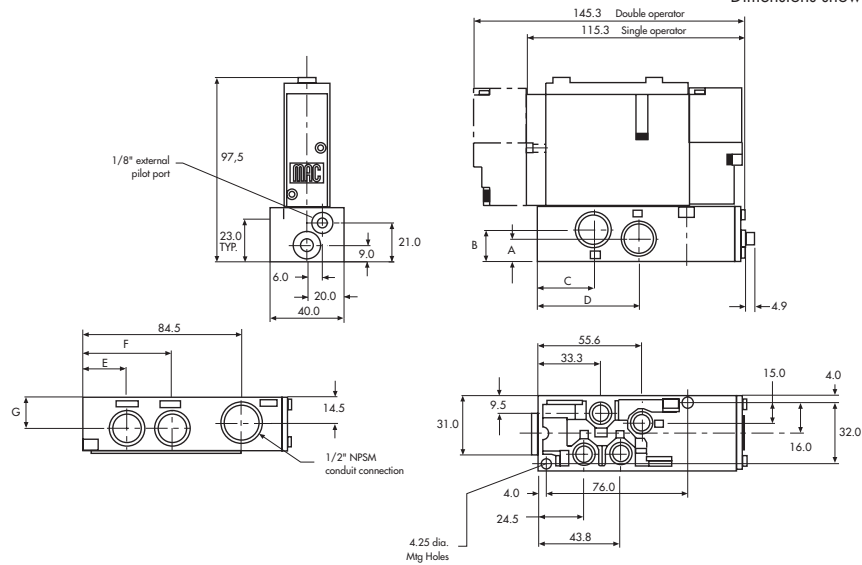

DIM.	A	B	C	D	E	F	G
1/8"	12.5	18.0	31.0	54.0	23.5	46.5	18.0
1/4"	12.5	18.0	31.0	54.0	23.5	46.5	18.0
3/8"	12.0	17.0	30.0	54.0	23.5	47.5	17.0



# Direct solenoid and solenoid pilot operated valves

Function	Port size	Flow (Max)	Manifold mounting	Series
<b>5/2, 5/3</b>	<b>1/4" - 3/8"</b>	<b>1.2 C<sub>v</sub></b>	Sub-base non "plug-in"	

### OPERATIONAL BENEFITS

1. The 4-way pilot develops maximum shifting forces both ways.
2. Memory spring available.
3. Balanced spool, immune to variations of pressure, also provides high flow.
4. Short stroke with high flow.
5. Bonded seal spool with minimum friction, shifting in a glass-like finished bore.
6. Pilot with balanced poppet, high flow; short and consistent response times.
7. Wiping effect eliminates sticking.
8. Long service life.



### HOW TO ORDER

#### SINGLE PRESSURE MODELS

Port size	Pilot air	5/2 Single operator	5/2 Double operator	5/3 Closed center	5/3 Open center	5/3 Pressure center
<b>Valve less base</b>		92B-ABA-000-DM-Dxxx-xxx	92B-BBA-000-DM-Dxxx-xxx	92B-EBA-000-DM-Dxxx-xxx	92B-FBA-000-DM-Dxxx-xxx	92B-GBA-000-DM-Dxxx-xxx
<b>1/4" NPTF</b>	Internal	92B-ABA-BJG-DM-Dxxx-xxx	92B-BBA-BJG-DM-Dxxx-xxx	92B-EBA-BJG-DM-Dxxx-xxx	92B-FBA-BJG-DM-Dxxx-xxx	92B-GBA-BJG-DM-Dxxx-xxx
<b>3/8" NPTF</b>		92B-ABA-CJG-DM-Dxxx-xxx	92B-BBA-CJG-DM-Dxxx-xxx	92B-EBA-CJG-DM-Dxxx-xxx	92B-FBA-CJG-DM-Dxxx-xxx	92B-GBA-CJG-DM-Dxxx-xxx

#### DUAL PRESSURE MODELS (REQUIRE SANDWICH REGULATOR – SEE "REGULATORS" SECTION)

Port size	Pilot air	5/2 Single operator	5/2 Double operator
<b>Valve less base</b>		92B-CBA-000-DM-Dxxx-xxx	92B-DBA-000-DM-Dxxx-xxx
<b>1/4" NPTF</b>	Internal	92B-CBA-BJG-DM-Dxxx-xxx	92B-DBA-BJG-DM-Dxxx-xxx
<b>3/8" NPTF</b>		92B-CBA-CJG-DM-Dxxx-xxx	92B-DBA-CJG-DM-Dxxx-xxx

Above models are shown with side ports.

#### SOLENOID OPERATOR >

DM-D **XXX-XXX**\*

XX Voltage	X Wire length	X Manual operator	XX Electrical connection
<b>JA</b> 110 /50, 120/60 (2.9W)	<b>A</b> 18" (flying leads)	<b>1</b> Non-locking recessed	<b>KA</b> Square connector
<b>JB</b> 220/50, 240/60 (2.9W)	<b>J</b> Connector	<b>2</b> Locking recessed	<b>KD</b> Square connector with light
<b>JC</b> 24/60 (2.9W)			<b>JB</b> Rectangular connector
<b>FB</b> 24 VDC (1.8W)			<b>JD</b> Rect. connector with light
<b>DA</b> 24 VDC (5.4W)			<b>BA</b> Flying leads
<b>DF</b> 24 VDC (12.7W)			<b>BK</b> Flying leads with diode

\* Other options available, see page 309.

End plate kit required (port size 3/8"): M-92004-01-01 (internal pilot)  
M-92004-02-01 (External pilot)

Other options available for the 92 series valves, see page 155.

- 33
- 34
- 36
- 32
- 37
- 38
- 52
- 67
- 69
- 44
- 46
- 42
- 47
- 48P
- 48
- 400
- 92
- 93
- ISO 01
- ISO 02
- ISO 1
- ISO 2
- ISO 3

**TECHNICAL DATA**

Fluid :	Compressed air, vacuum, inert gases		
Pressure range :	Internal pilot : 20 to 120 PSI	3 position : 35 to 120 PSI	
	External pilot : vacuum to 120 PSI	3 position : 35 to 120 PSI	
Lubrication :	Not required, if used select a medium aniline point lubricant (between 180°F and 210°F)		
Filtration :	40 μ		
Temperature range :	0°F to 120°F (-18°C to +50°C)		
Flow :	1/4": (1.1 C <sub>v</sub> ) – 3/8": (1.2 C <sub>v</sub> )		
Coil :	Class A continuous duty, #22 AWG x 18 leads		
Voltage range :	-15% to +10% of nominal voltage		
Protection :	Consult factory		
Power :	~Inrush 7.6 VA    Holding : 4.8 VA = 1.8 to 12.7 W		
Response times :	24V=5.4W	Energize : 8 ms	De-energize : 7 ms
	120/60	Energize : 7-13 ms	De-energize : 12-20 ms

Options : • BSPB threads • Sandwich flow controls: FC92B-CA

Spare parts : • Pilot valve: DM-Dxxx-xxx • Valve blanking plate: M-92002 • Pressure seal, valve to base 16543  
• Inlet/Exhaust isolator disc: N-92018.

**DIMENSIONS**

Dimensions shown are metric (mm)

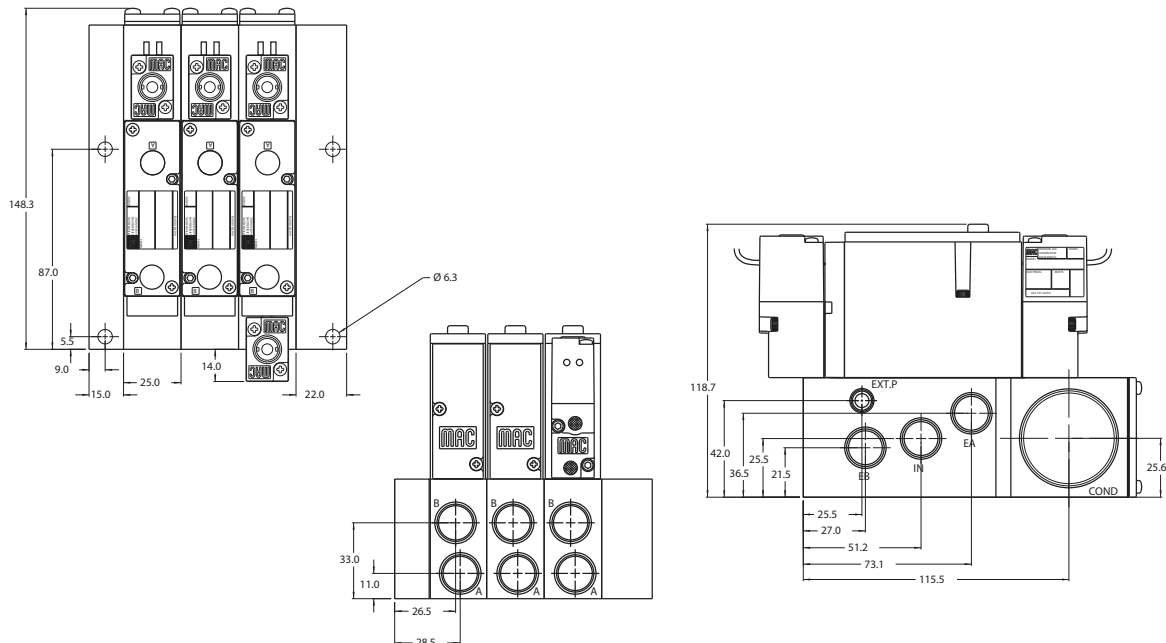

Function	Port size	Flow (Max)	Manifold mounting	Series
<b>5/2, 5/3</b>	<b>1/4" - 3/8"</b>	<b>1.2 C<sub>v</sub></b>	Sub-base "plug-in"	



### OPERATIONAL BENEFITS

1. The 4-way pilot develops maximum shifting forces both ways.
2. Memory spring available.
3. Balanced spool, immune to variations of pressure, also provides high flow.
4. Short stroke with high flow.
5. Bonded seal spool with minimum friction, shifting in a glass-like finished bore.
6. Pilot with balanced poppet, high flow; short and consistent response times.
7. Wiping effect eliminates sticking.
8. Long service life.



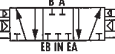
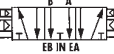
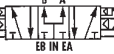

### HOW TO ORDER

#### SINGLE PRESSURE MODELS

Port size	Pilot air	5/2 Single operator	5/2 Double operator	5/3 Closed center	5/3 Open center	5/3 Pressure center
						
<b>Valve less base</b>		92B-AAA-000-DM-DxxP-xxx	92B-BAA-000-DM-DxxP-xxx	92B-EAA-000-DM-DxxP-xxx	92B-FAA-000-DM-DxxP-xxx	92B-GAA-000-DM-DxxP-xxx
<b>1/4" NPTF</b>	Internal	92B-AAA-BJA-DM-DxxP-xxx	92B-BAA-BJA-DM-DxxP-xxx	92B-EAA-BJA-DM-DxxP-xxx	92B-FAA-BJA-DM-DxxP-xxx	92B-GAA-BJA-DM-DxxP-xxx
<b>3/8" NPTF</b>		92B-AAA-CJA-DM-DxxP-xxx	92B-BAA-CJA-DM-DxxP-xxx	92B-EAA-CJA-DM-DxxP-xxx	92B-FAA-CJA-DM-DxxP-xxx	92B-GAA-CJA-DM-DxxP-xxx

#### DUAL PRESSURE MODELS (REQUIRE SANDWICH REGULATOR – SEE "REGULATORS" SECTION)

Port size	Pilot air	5/2 Single operator	5/2 Double operator
			
<b>Valve less base</b>		92B-CAA-000-DM-DxxP-xxx	92B-DAA-000-DM-DxxP-xxx
<b>1/4" NPTF</b>	Internal	92B-CAA-BJA-DM-DxxP-xxx	92B-DAA-BJA-DM-DxxP-xxx
<b>3/8" NPTF</b>		92B-CAA-CJA-DM-DxxP-xxx	92B-DAA-CJA-DM-DxxP-xxx

#### SOLENOID OPERATOR >

### DM-D **XX** P-**XXX**\*

Above models are shown with side ports and no lights.

XX Voltage	X Manual operator	XX Electrical connection
<b>JA</b> 110 / 50, 120 / 60 (2.9W)	<b>1</b> Non-locking recessed	<b>DM</b> Plug-in
<b>JB</b> 220 / 50, 240 / 60 (2.9W)	<b>2</b> Locking recessed	<b>DN</b> Plug-in with diode
<b>JC</b> 24 / 60 (2.9W)		<b>DP</b> Plug-in with M.O.V.
<b>FB</b> 24 VDC (1.8W)		<b>DG</b> Plug-in with ground
<b>DA</b> 24 VDC (5.4W)		<b>DJ</b> Plug-in with M.O.V. & ground
<b>DF</b> 24 VDC (12.7W)		<b>DH</b> Plug-in with diode & ground

\* Other options available, see page 309.

Note: Ground required for 30 Volts or higher.

End plate kit required (port size 3/8"): M-92004-01-01 (internal pilot)  
M-92004-02-01 (external pilot)

Other options available for the 92 series valves, see page 156.

33  
34  
36  
32  
37  
38  
52  
67  
69  
44  
46  
42  
47  
48P  
48  
400  
92  
93  
ISO 01  
ISO 02  
ISO 1  
ISO 2  
ISO 3

**TECHNICAL DATA**

Fluid :	Compressed air, vacuum, inert gases		
Pressure range :	Internal pilot : 20 to 120 PSI	3 position : 35 to 120 PSI	
	External pilot : vacuum to 120 PSI	3 position : 35 to 120 PSI	
Lubrication :	Not required, if used select a medium aniline point lubricant (between 180°F and 210°F)		
Filtration :	40 μ		
Temperature range :	0°F to 120°F (-18°C to +50°C)		
Flow :	1/4": (1.1 C <sub>v</sub> ) – 3/8": (1.2 C <sub>v</sub> )		
Coil :	Class A continuous duty, #22 AWG x 12 base leads		
Voltage range :	-15% to +10% of nominal voltage		
Protection :	Consult factory		
Power :	~Inrush 7.6 VA Holding : 4.8 VA = 1.8 to 12.7 W		
Response times :	24V=5.4W	Energize : 8 ms	De-energize : 7 ms
	120/60	Energize : 7-13 ms	De-energize : 12-20 ms

Options : • BSPP threads • Sandwich flow controls: FC92B-AA (sgl. operator), FC92B-BA (dbl. operator)

Spare parts : • Pilot valve: DM-DxxP-xxx • Valve blanking plate: M-92002 • Pressure seal, valve to base: 16543  
• Mounting screws valve to base (x2): 35050 • Inlet/Exhaust isolator disc: N-92018.

**DIMENSIONS**

Dimensions shown are metric (mm)

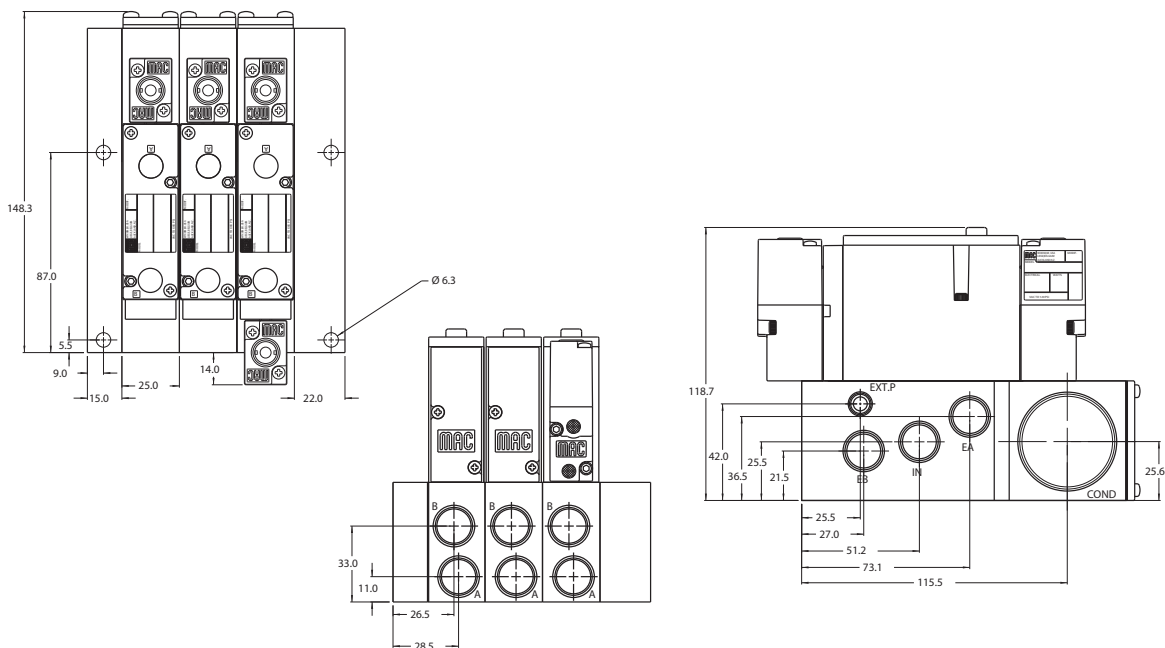



<b>OPTIONS FOR NON PLUG-IN VALVES</b>	<b>33</b>
<b>Valve function</b>	<b>34</b>
92B- <b>H</b> XX-XXX-XX-Dxxx-xxx	<b>36</b>
<ul style="list-style-type: none"> <li><b>H</b> for 3 position dual pressure, pressure center*</li> <li><b>J</b> for 3 position dual pressure, closed center*</li> <li><b>K</b> for 3 position dual pressure, open center*</li> <li><b>L</b> for single operator, single pressure with memory spring</li> <li><b>N</b> for single operator, dual pressure with memory spring*</li> </ul>	<b>32</b>
<b>Pilot exhaust</b>	<b>37</b>
92B-X <b>B</b> X-XXX-XX-Dxxx-xxx	<b>38</b>
<ul style="list-style-type: none"> <li><b>B</b> standard pilot exhaust</li> <li><b>D</b> pilot exhaust to main valve exhaust**</li> </ul>	<b>52</b>
<b>Port configuration :</b>	<b>67</b>
<b>Individual sub-base</b>	<b>69</b>
92B-XXX-X <b>A</b> X-XX-Dxxx-xxx	<b>44</b>
<ul style="list-style-type: none"> <li><b>A</b> side ports</li> <li><b>B</b> bottom ports (1/8" only)</li> <li><b>C</b> side &amp; bottom ports (1/8" only)</li> <li><b>D</b> side inlet &amp; exhaust with bottom cylinder ports (1/8")</li> </ul>	<b>46</b>
<b>Manifold sub-base</b>	<b>42</b>
92B-XXX-X <b>J</b> X-XX-Dxxx-xxx	<b>47</b>
<ul style="list-style-type: none"> <li><b>J</b> side ports</li> <li><b>K</b> bottom ports</li> </ul>	<b>48P</b>
<b>Pilot style :</b>	<b>48</b>
92B-XXX-XXX- <b>DM</b> -Dxxx-xxx	<b>400</b>
<ul style="list-style-type: none"> <li><b>DM</b> pilot exhaust muffled</li> <li><b>DP</b> pilot exhaust piped (#10-32)</li> <li><b>DU</b> pilot exhaust to main exhaust</li> </ul>	<b>92</b>
<b>Base only :</b>	
92B-000-XXX (i.e. 92B-000-AAG) - Individual base	
92B-000-XXX (i.e. 92B-000-BJG) - Manifold base	

\* Requires sandwich regulator.  
 \*\* Must use DU pilot. Main valve exhaust cannot be restricted.

- 93**
- ISO 01**
- ISO 02**
- ISO 1**
- ISO 2**
- ISO 3**



# Direct solenoid and solenoid pilot operated valves

## OPTIONS FOR PLUG-IN VALVES

### Valve function

92B-**HXX**-XXX-XX-**DxxP**-xxx

- H** for 3 position dual pressure, pressure center\*
- J** for 3 position dual pressure, closed center\*
- K** for 3 position dual pressure, open center\*
- L** for single operator, single pressure with memory spring
- N** for single operator, dual pressure with memory spring\*

### Pilot exhaust

92B-X**AX**-XXX-XX-**DxxP**-xxx

- A** standard pilot exhaust
- C** pilot exhaust to main valve exhaust\*\*

### Body electrical

92B-XX**A**-XXX-XX-**DxxP**-xxx

- A** no light
- B** light(s)
- F** suppression and blocking diode with light(s)
- H** M.O.V. with light(s)

### Port configuration :

#### Individual sub-base

92B-XXX-X**AX**-XX-**DxxP**-xxx

- A** side ports
- B** bottom ports (1/8" only)
- C** side & bottom ports (1/8" only)
- D** side inlet & exhaust with bottom cylinder ports (1/8")

#### Manifold sub-base

92B-XXX-X**JX**-XX-**DxxP**-xxx

- J** side ports
- K** bottom ports

#### Individual & Manifold sub-base Int. pilot

92B-XXX-XX**A**-XX-**DxxP**-xxx

- A** internal pilot no light
- B** internal pilot single light
- C** internal pilot double light

#### Individual sub-base Ext. pilot

92B-XXX-XX**D**-XX-**DxxP**-xxx

- D** external pilot no light
- E** external pilot single light
- F** external pilot double light

### Pilot style :

92B-XXX-XXX-**DM**-**DxxP**-xxx

- DM** pilot exhaust muffled
- DP** pilot exhaust piped (#10-32)
- DU** pilot exhaust to main exhaust

### Lead Wire Lengths : (manifold sub-base only)

92B-XXX-XXX-**DM**-**DxxP**-xxx

- P** 12" leads
- 1** 18" leads
- 2** 24" leads
- 3** 36" leads
- 4** 48" leads
- 5** 72" leads

### Base only :

92B-000-XXX (i.e. 92B-000-AAA) - Individual base

(Note: bases are wired for double solenoid valves)

92B-000-XXX (i.e. 92B-000-BJA) - Manifold base

\* Requires sandwich regulator.

\*\* Must use DU pilot. Main valve exhaust cannot be restricted.

Individual mounting

Inline	Sub-base non "plug-in"	Sub-base "plug-in"
--------	------------------------	--------------------

Series

Manifold mounting

Sub-base non "plug-in"	Sub-base "plug-in"
------------------------	--------------------

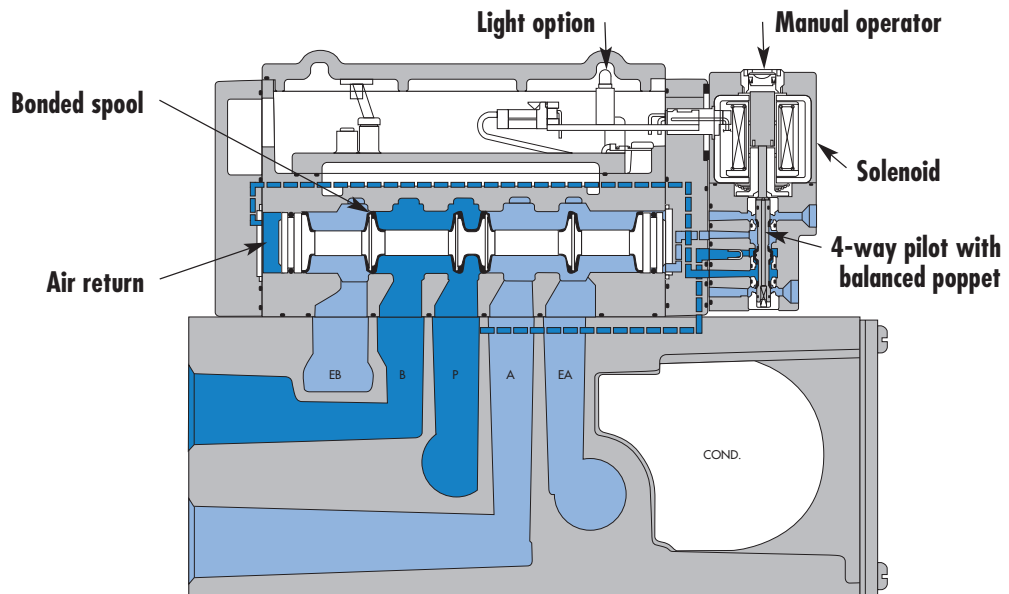

33

34

36

32

37

38

52

67

69

44

46

42

47

48P

48

48

48

48

400

92

92

**SERIES FEATURES**

- Patented MACSOLENOID® for fastest possible response times and virtually burn-out proof AC solenoid operation.
- Optional low watt DC solenoids.
- Optional memory spring.
- Plug-in design of valves and bases for ease of maintenance.
- 2 position or 3 position valve configurations.

93

ISO 01

ISO 02

ISO 1

ISO 2

ISO 3

**SPOOL CONFIGURATIONS**

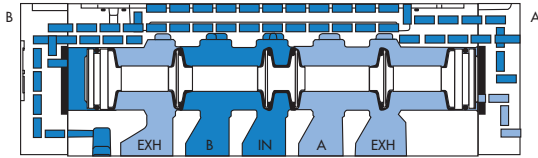

2 POSITION SINGLE PRESSURE  
SHOWN WITH "B" OPERATOR ENERGIZED

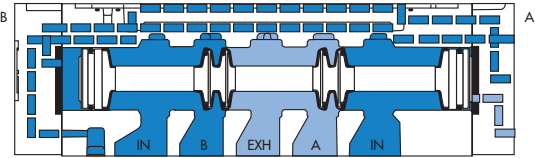

2 POSITION DUAL PRESSURE  
SHOWN WITH "B" OPERATOR ENERGIZED

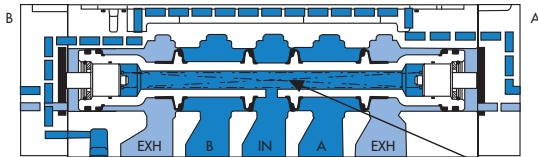

3 POSITION CLOSED CENTER

**SPRING CENTERING**

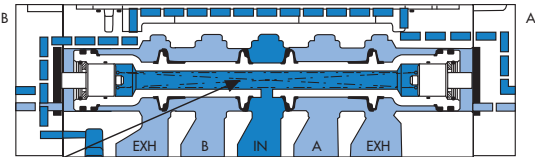

3 POSITION OPEN CENTER

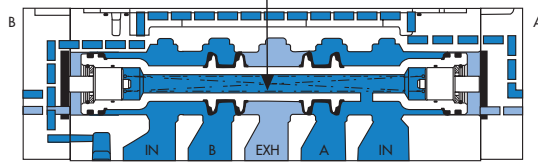

3 POSITION DUAL PRESSURE, PRESSURE CENTER

**REGULATOR CONFIGURATIONS**

**SINGLE REGULATOR - SINGLE PRESSURE**

Pressure supplied to the individual or manifold base passes through the regulator. Regulated pressure is supplied to the pressure path of the valve.

**DUAL REGULATOR - DUAL PRESSURE**

Pressure supplied from each regulator is divided in the block. Regulated pressure from "A" regulator supplies cylinder port "A". Regulated pressure from "B" regulator supplies cylinder port "B". Dual pressure regulators require dual pressure spool in valve.

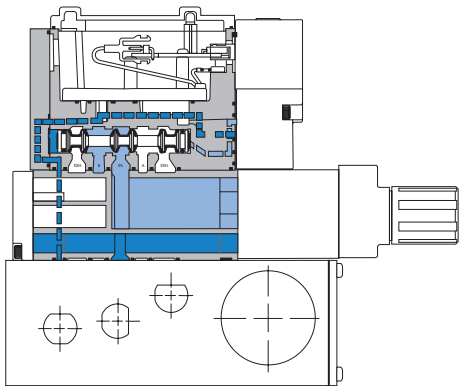

**MANIFOLD WITH REGULATOR - SINGLE PRESSURE**

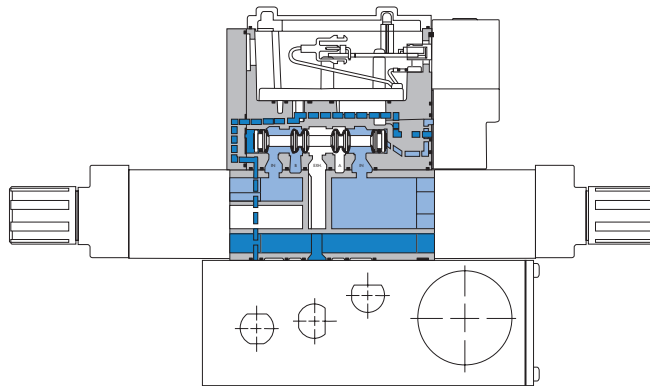

**MANIFOLD WITH REGULATOR - DUAL PRESSURE**

**Note:** For both single and dual pressure, air supply to the pilot system is never regulated.

Function	Port size	Flow (Max)	Individual mounting	Series
<b>5/2, 5/3</b>	<b>3/8" - 1/2"</b>	<b>3.8 C<sub>v</sub></b>	Inline	

### OPERATIONAL BENEFITS

1. Unique patented Macsolenoid® for fastest possible response times and virtually burn-out proof solenoid operation.
2. Balanced poppet 4-way pilot valve provides maximum shifting forces, precise repeatability and consistent operation.
3. Air only return. Optional memory spring is also available.
4. Optional low wattage DC solenoid down to 1 watt.
5. MAC spool and bore combination wipes away contamination, eliminates sticking and allows for use on non-lube service.

### HOW TO ORDER

#### SINGLE PRESSURE MODELS

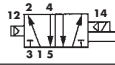
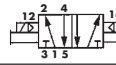
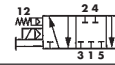
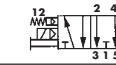
Port size	Pilot air	5/2 Single operator	5/2 Double operator	5/3 Closed center	5/3 Open center
					
<b>3/8" NPTF</b>	Internal	93A-AJ0-B0J-DM-Dxxx-xxx	93A-BJ0-B0J-DM-Dxxx-xxx	93A-EJ0-B0J-DM-Dxxx-xxx	93A-FJ0-B0J-DM-Dxxx-xxx
<b>1/2" NPTF</b>	Internal	93A-AJ0-C0J-DM-Dxxx-xxx	93A-BJ0-C0J-DM-Dxxx-xxx	93A-EJ0-C0J-DM-Dxxx-xxx	93A-FJ0-C0J-DM-Dxxx-xxx
<b>3/8" NPTF</b>	External	93A-AJ0-B0K-DM-Dxxx-xxx	93A-BJ0-B0K-DM-Dxxx-xxx	93A-EJ0-B0K-DM-Dxxx-xxx	93A-FJ0-B0K-DM-Dxxx-xxx
<b>1/2" NPTF</b>	External	93A-AJ0-C0K-DM-Dxxx-xxx	93A-BJ0-C0K-DM-Dxxx-xxx	93A-EJ0-C0K-DM-Dxxx-xxx	93A-FJ0-C0K-DM-Dxxx-xxx

#### DUAL PRESSURE MODELS

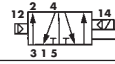
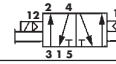
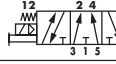
Port size	Pilot air	5/2 Single operator	5/2 Double operator	5/3 Pressure center
				
<b>3/8" NPTF</b>	Internal	93A-CJ0-B0J-DM-Dxxx-xxx	93A-DJ0-B0J-DM-Dxxx-xxx	93A-HJ0-B0J-DM-Dxxx-xxx
<b>1/2" NPTF</b>	Internal	93A-CJ0-C0J-DM-Dxxx-xxx	93A-DJ0-C0J-DM-Dxxx-xxx	93A-HJ0-C0J-DM-Dxxx-xxx
<b>3/8" NPTF</b>	External	93A-CJ0-B0K-DM-Dxxx-xxx	93A-DJ0-B0K-DM-Dxxx-xxx	93A-HJ0-B0K-DM-Dxxx-xxx
<b>1/2" NPTF</b>	External	93A-CJ0-C0K-DM-Dxxx-xxx	93A-DJ0-C0K-DM-Dxxx-xxx	93A-HJ0-C0K-DM-Dxxx-xxx

#### SOLENOID OPERATOR >

### DM-D **XXX-XXX**\*

XX Voltage	X Wire length	X Manual operator	XX Electrical connection
<b>JA</b> 110/50, 120/60	<b>A</b> 18" (Flying leads)	<b>1</b> Non-locking recessed	<b>KA</b> Square connector
<b>JB</b> 220/50, 240/60	<b>B</b> 24" (Flying leads)	<b>2</b> Locking recessed	<b>KD</b> Square connector with light
<b>JC</b> 24/50, 24/60	<b>J</b> Connector		<b>JB</b> Rectangular connector
<b>FB</b> 24 VDC (1.8W)			<b>JD</b> Rectangular connector with light
<b>DA</b> 24 VDC (5.4W)			<b>BA</b> Flying leads
<b>DF</b> 24 VDC (12.7W)			

\* Other options available, see page 309.

### OPTIONS

Pilot exhaust : 93A-XJX-XXX-DM-Dxxx-xxx

- J** Standard pilot exhaust
- K** Pilot exhaust to main exhaust (use DU pilot)

Other options available for the 93 series valves, see page 169.

33  
34  
36  
32  
37  
38  
52  
67  
69  
44  
46  
42  
47  
48P  
48  
400  
92  
93  
ISO 01  
ISO 02  
ISO 1  
ISO 2  
ISO 3



**TECHNICAL DATA**

<b>Fluid :</b>	Compressed air, vacuum, inert gases
<b>Pressure range :</b>	Internal Pilot: 20 to 120 PSI External Pilot: Vacuum to 120 PSI
<b>Lubrication :</b>	Not required, if used select a medium aniline point lubricant (between 180°F and 210°F)
<b>Filtration :</b>	40 µ
<b>Temperature range :</b>	0°F to 120°F (-18°C to +50°C)
<b>Flow :</b>	3.8 C <sub>v</sub>
<b>Coil :</b>	Class A continuous duty, #22 AWG x 18 leads
<b>Voltage range :</b>	-1.5% to +10% of nominal voltage
<b>Protection :</b>	Consult factory
<b>Power :</b>	~ Inrush 7.6 VA    Holding: 4.8 VA = 1.8 to 12.7 W
<b>Response times : (with 5.4 W coil)</b>	Energize : 13 ms De-energize : 10 ms

Option :                    • BSPP threads

**DIMENSIONS**

Dimensions shown are metric (mm)

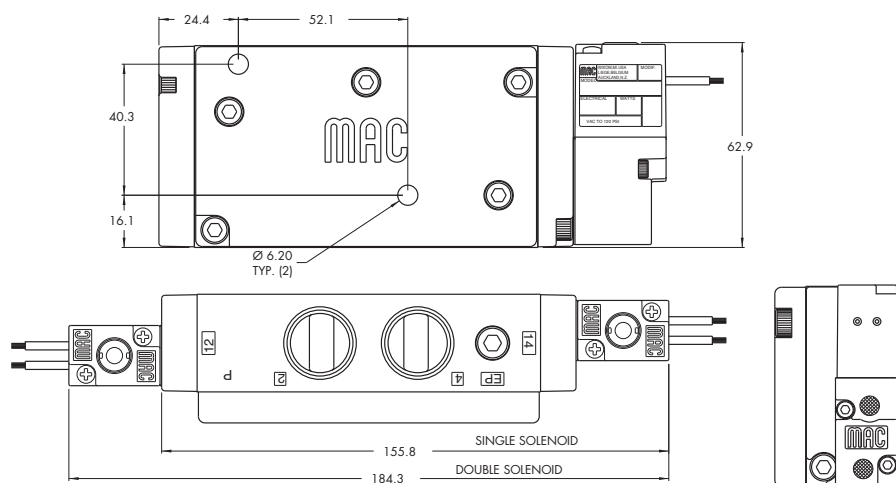



# Direct solenoid and solenoid pilot operated valves

Function	Port size	Flow (Max)	Individual mounting	Series
<b>5/2, 5/3</b>	<b>1/4" - 3/8" - 1/2"</b>	<b>3.4 C<sub>v</sub></b>	Sub-base non "plug-in"	

### OPERATIONAL BENEFITS

1. Unique patented Macsolenoid® for fastest possible response times and virtually burn-out proof solenoid operation.
2. Balanced poppet 4-way pilot valve provides maximum shifting forces, precise repeatability and consistent operation.
3. Air only return. Optional memory spring is also available.
4. Optional low wattage DC solenoid down to 1 watt.
5. MAC spool and bore combination wipes away contamination, eliminates sticking and allows for use on non-lube service.

### HOW TO ORDER

SINGLE PRESSURE MODELS (1/4" MODELS ARE BOTTOM PORTED)

Port size	Pilot air	5/2 Single operator	5/2 Double operator	5/3 Closed center	5/3 Open center
<b>Valve less base</b>		93A-ABA-000-DM-Dxxx-xxx	93A-BBA-000-DM-Dxxx-xxx	93A-EBA-000-DM-Dxxx-xxx	93A-FBA-000-DM-Dxxx-xxx
<b>1/4" NPTF</b>		93A-ABA-ABG-DM-Dxxx-xxx	93A-BBA-ABG-DM-Dxxx-xxx	93A-EBA-ABG-DM-Dxxx-xxx	93A-FBA-ABG-DM-Dxxx-xxx
<b>3/8" NPTF</b>	Internal	93A-ABA-BAG-DM-Dxxx-xxx	93A-BBA-BAG-DM-Dxxx-xxx	93A-EBA-BAG-DM-Dxxx-xxx	93A-FBA-BAG-DM-Dxxx-xxx
<b>1/2" NPTF</b>		93A-ABA-CAG-DM-Dxxx-xxx	93A-BBA-CAG-DM-Dxxx-xxx	93A-EBA-CAG-DM-Dxxx-xxx	93A-FBA-CAG-DM-Dxxx-xxx
<b>1/4" NPTF</b>		93A-ABA-ABH-DM-Dxxx-xxx	93A-BBA-ABH-DM-Dxxx-xxx	93A-EBA-ABH-DM-Dxxx-xxx	93A-FBA-ABH-DM-Dxxx-xxx
<b>3/8" NPTF</b>	External	93A-ABA-BAH-DM-Dxxx-xxx	93A-BBA-BAH-DM-Dxxx-xxx	93A-EBA-BAH-DM-Dxxx-xxx	93A-FBA-BAH-DM-Dxxx-xxx
<b>1/2" NPTF</b>		93A-ABA-CAH-DM-Dxxx-xxx	93A-BBA-CAH-DM-Dxxx-xxx	93A-EBA-CAH-DM-Dxxx-xxx	93A-FBA-CAH-DM-Dxxx-xxx

DUAL PRESSURE MODELS REQUIRE SANDWICH REGULATOR, SEE „REGULATORS“ SECTION (1/4" MODELS ARE BOTTOM PORTED)

Port size	Pilot air	5/2 Single operator	5/2 Double operator	5/3 Pressure center
<b>Valve less base</b>		93A-CBA-000-DM-Dxxx-xxx	93A-DBA-000-DM-Dxxx-xxx	93A-HBA-000-DM-Dxxx-xxx
<b>1/4" NPTF</b>		93A-CBA-ABG-DM-Dxxx-xxx	93A-DBA-ABG-DM-Dxxx-xxx	93A-HBA-ABG-DM-Dxxx-xxx
<b>3/8" NPTF</b>	Internal	93A-CBA-BAG-DM-Dxxx-xxx	93A-DBA-BAG-DM-Dxxx-xxx	93A-HBA-BAG-DM-Dxxx-xxx
<b>1/2" NPTF</b>		93A-CBA-CAG-DM-Dxxx-xxx	93A-DBA-CAG-DM-Dxxx-xxx	93A-HBA-CAG-DM-Dxxx-xxx
<b>1/4" NPTF</b>		93A-CBA-ABH-DM-Dxxx-xxx	93A-DBA-ABH-DM-Dxxx-xxx	93A-HBA-ABH-DM-Dxxx-xxx
<b>3/8" NPTF</b>	External	93A-CBA-BAH-DM-Dxxx-xxx	93A-DBA-BAH-DM-Dxxx-xxx	93A-HBA-BAH-DM-Dxxx-xxx
<b>1/2" NPTF</b>		93A-CBA-CAH-DM-Dxxx-xxx	93A-DBA-CAH-DM-Dxxx-xxx	93A-HBA-CAH-DM-Dxxx-xxx

SOLENOID OPERATOR >

DM-D **XXX-XXX**\*

XX Voltage	X Wire length	X Manual operator	XX Electrical connection
<b>JA</b> 110/50, 120/60	<b>A</b> 18" (Flying leads)	<b>1</b> Non-locking recessed	<b>BM</b> Flying leads
<b>JB</b> 220/50, 240/60	<b>B</b> 24" (Flying leads)	<b>2</b> Locking recessed	<b>BN</b> Flying leads with diode
<b>JC</b> 24/50, 24/60	<b>J</b> Connector		<b>BP</b> Flying leads with M.O.V.
<b>FB</b> 24 VDC (1.8W)			<b>BG</b> Flying leads with ground
<b>DA</b> 24 VDC (5.4W)			<b>JB</b> Rectangular connector
<b>DF</b> 24 VDC (12.7W)			<b>JD</b> Rectangular connector with light

\* Other options available, see page 309.  
Other options available for the 93 series valves, see page 169.

33  
34  
36  
32  
37  
38  
52  
67  
69  
44  
46  
42  
47  
48P  
48  
400  
92  
93  
ISO 01  
ISO 02  
ISO 1  
ISO 2  
ISO 3



**TECHNICAL DATA**

<b>Fluid :</b>	Compressed air, vacuum, inert gases
<b>Pressure range :</b>	Internal Pilot: 20 to 120 PSI External Pilot: Vacuum to 120 PSI
<b>Lubrication :</b>	Not required, if used select a medium aniline point lubricant (between 180°F and 210°F)
<b>Filtration :</b>	40 µ
<b>Temperature range :</b>	0°F to 120°F (-18°C to +50°C)
<b>Flow :</b>	1/4", 3/8" : (3.0 C <sub>v</sub> ) - 1/2" : (3.4 C <sub>v</sub> )
<b>Coil :</b>	Class A continuous duty, #22 AWG x 18 leads
<b>Voltage range :</b>	-1.5% to +10% of nominal voltage
<b>Protection :</b>	Consult factory
<b>Power :</b>	~ Inrush 7.6 VA    Holding: 4.8 VA = 1 to 12.7 W
<b>Response times : (with 5.4 W coil)</b>	Energize : 13 ms De-energize : 10 ms

- Options :
- BSPP thread • Sandwich regulator (see ,regulators' section)
  - Sandwich flow controls    FC93A-BA (screwdriver slot adjustment)  
  FC93A-BB (locking knob adjustment)

- Spare parts :
- Pilot valve: DM-Dxxx-xxx • Valve to base pressure seal: 16622
  - Pilot valve pressure seal: 16542 • Mounting screws valve to base (x4): 35249
  - Pilot valve mounting screws (x2): 35069

**DIMENSIONS**

Dimensions shown are metric (mm)

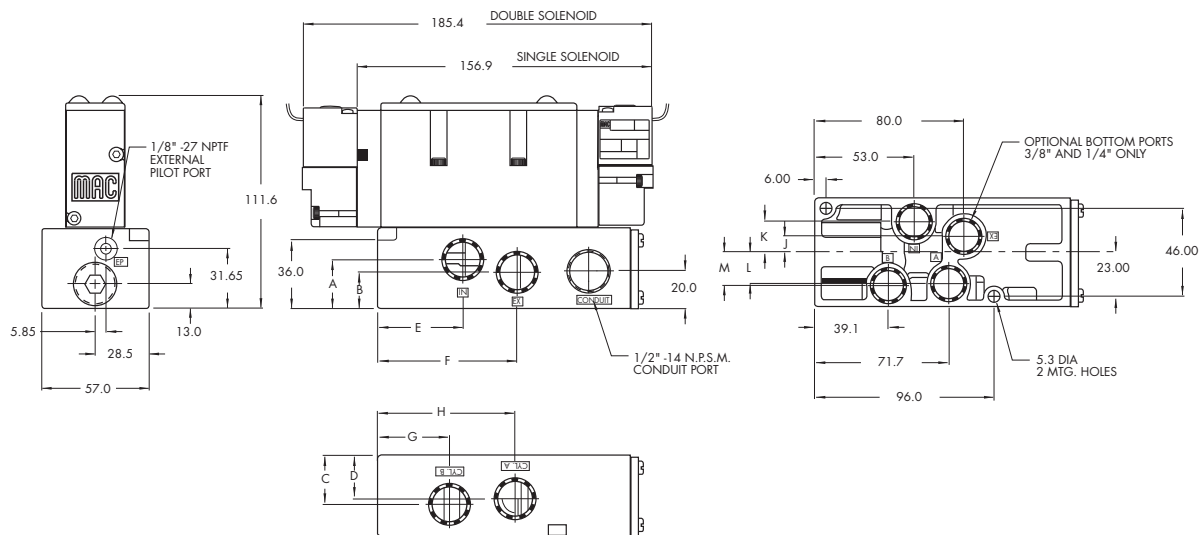

DIM.	A	B	C	D	E	F	G	H	DIM.	J	K	L	M
3/8"	27.15	20.65	27.15	24.15	54.1	81.7	38.2	73.5	1/4"	7.0	14.7	15.0	16.5
1/2"	25.5	19.0	25.5	22.5	45.8	75.3	38.2	73.5	3/8"	8.5	16.2	16.5	17.5





# Direct solenoid and solenoid pilot operated valves

Function	Port size	Flow (Max)	Individual mounting	Series
<b>5/2, 5/3</b>	<b>1/4" - 3/8" - 1/2"</b>	<b>3.4 C<sub>v</sub></b>	Sub-base "plug-in"	

### OPERATIONAL BENEFITS

1. Unique patented Macsolenoid® for fastest possible response times and virtually burn-out proof solenoid operation.
2. Balanced poppet 4-way pilot valve provides maximum shifting forces, precise repeatability and consistent operation.
3. Air only return. Optional memory spring is also available.
4. Optional low wattage DC solenoid down to 1 watt.
5. MAC spool and bore combination wipes away contamination, eliminates sticking and allows for use on non-lube service.

### HOW TO ORDER

SINGLE PRESSURE MODELS (1/4" MODELS ARE BOTTOM PORTED)

Port size	Pilot air	5/2 Single operator	5/2 Double operator	5/3 Closed center	5/3 Open center
<b>Valve less base</b>		93A-AAA-000-DM-DxxP-xxx	93A-BAA-000-DM-DxxP-xxx	93A-EAA-000-DM-DxxP-xxx	93A-FAA-000-DM-DxxP-xxx
<b>1/4" NPTF</b>		93A-AAA-ABA-DM-DxxP-xxx	93A-BAA-ABA-DM-DxxP-xxx	93A-EAA-ABA-DM-DxxP-xxx	93A-FAA-ABA-DM-DxxP-xxx
<b>3/8" NPTF</b>	Internal	93A-AAA-BAA-DM-DxxP-xxx	93A-BAA-BAA-DM-DxxP-xxx	93A-EAA-BAA-DM-DxxP-xxx	93A-FAA-BAA-DM-DxxP-xxx
<b>1/2" NPTF</b>		93A-AAA-CAA-DM-DxxP-xxx	93A-BAA-CAA-DM-DxxP-xxx	93A-EAA-CAA-DM-DxxP-xxx	93A-FAA-CAA-DM-DxxP-xxx
<b>1/4" NPTF</b>		93A-AAA-ABD-DM-DxxP-xxx	93A-BAA-ABD-DM-DxxP-xxx	93A-EAA-ABD-DM-DxxP-xxx	93A-FAA-ABD-DM-DxxP-xxx
<b>3/8" NPTF</b>	External	93A-AAA-BAD-DM-DxxP-xxx	93A-BAA-BAD-DM-DxxP-xxx	93A-EAA-BAD-DM-DxxP-xxx	93A-FAA-BAD-DM-DxxP-xxx
<b>1/2" NPTF</b>		93A-AAA-CAD-DM-DxxP-xxx	93A-BAA-CAD-DM-DxxP-xxx	93A-EAA-CAD-DM-DxxP-xxx	93A-FAA-CAD-DM-DxxP-xxx

DUAL PRESSURE MODELS REQUIRE SANDWICH REGULATOR, SEE „REGULATORS“ SECTION (1/4" MODELS ARE BOTTOM PORTED)

Port size	Pilot air	5/2 Single operator	5/2 Double operator	5/3 Pressure Center
<b>Valve less base</b>		93A-CAA-000-DM-DxxP-xxx	93A-DAA-000-DM-DxxP-xxx	93A-HAA-000-DM-DxxP-xxx
<b>1/4" NPTF</b>		93A-CAA-ABA-DM-DxxP-xxx	93A-DAA-ABA-DM-DxxP-xxx	93A-HAA-ABA-DM-DxxP-xxx
<b>3/8" NPTF</b>	Internal	93A-CAA-BAA-DM-DxxP-xxx	93A-DAA-BAA-DM-DxxP-xxx	93A-HAA-BAA-DM-DxxP-xxx
<b>1/2" NPTF</b>		93A-CAA-CAA-DM-DxxP-xxx	93A-DAA-CAA-DM-DxxP-xxx	93A-HAA-CAA-DM-DxxP-xxx
<b>1/4" NPTF</b>		93A-CAA-ABD-DM-DxxP-xxx	93A-DAA-ABD-DM-DxxP-xxx	93A-HAA-ABD-DM-DxxP-xxx
<b>3/8" NPTF</b>	External	93A-CAA-BAD-DM-DxxP-xxx	93A-DAA-BAD-DM-DxxP-xxx	93A-HAA-BAD-DM-DxxP-xxx
<b>1/2" NPTF</b>		93A-CAA-CAD-DM-DxxP-xxx	93A-DAA-CAD-DM-DxxP-xxx	93A-HAA-CAD-DM-DxxP-xxx

SOLENOID OPERATOR >

DM-D **XX** P-**XXX**\*

Above models are shown without light.

XX Voltage	X Manual operator	XX Electrical connection
<b>JA</b> 110/50, 120/60 (2.9W)	<b>1</b> Non-locking recessed	<b>DM</b> Plug-in
<b>JB</b> 220/50, 240/60 (2.9W)	<b>2</b> Locking recessed	<b>DN</b> Plug-in with diode
<b>JC</b> 24/50, 24/60 (2.9W)		<b>DP</b> Plug-in with M.O.V.
<b>FB</b> 24 VDC (1.8W)		<b>DG</b> Plug-in with ground
<b>DA</b> 24 VDC (5.4W)		
<b>DF</b> 24 VDC (12.7W)		

\* Other options available, see page 309.  
Note: Ground required for 30 Volts or higher.  
Other options available for the 93 series valves, see page 170.

33  
34  
36  
32  
37  
38  
52  
67  
69  
44  
46  
42  
47  
48P  
48  
400  
92  
93  
ISO 01  
ISO 02  
ISO 1  
ISO 2  
ISO 3



**TECHNICAL DATA**

<b>Fluid :</b>	Compressed air, vacuum, inert gases
<b>Pressure range :</b>	Internal Pilot: 20 to 120 PSI External Pilot: Vacuum to 120 PSI
<b>Lubrication :</b>	Not required, if used select a medium aniline point lubricant (between 180°F and 210°F)
<b>Filtration :</b>	40 µ
<b>Temperature range :</b>	0°F to 120°F (-18°C to +50°C)
<b>Flow :</b>	1/4", 3/8" : (3.0 C <sub>v</sub> ) - 1/2" : (3.4 C <sub>v</sub> )
<b>Coil :</b>	Class A continuous duty, #22 AWG x 18 base leads
<b>Voltage range :</b>	-15% to +10% of nominal voltage
<b>Protection :</b>	Consult factory
<b>Power :</b>	~ Inrush 7.6 VA Holding: 4.8 VA = 1 to 12.7 W
<b>Response times : (with 5.4 W coil)</b>	Energize : 13 ms De-energize : 10 ms

- Options :
- BSPP thread • Sandwich regulator (see ,regulators' section)
  - Sandwich flow controls FC93A-AA (screwdriver slot adjustment)  
FC93A-AB (locking knob adjustment)

- Spare parts :
- Pilot valve: DM-DxxP-xxx • Valve to base pressure seal: 16622
  - Pilot valve pressure seal: 16542 • Mounting screws valve to base (x4): 35249
  - Pilot valve mounting screws (x2): 35069

**DIMENSIONS**

Dimensions shown are metric (mm)

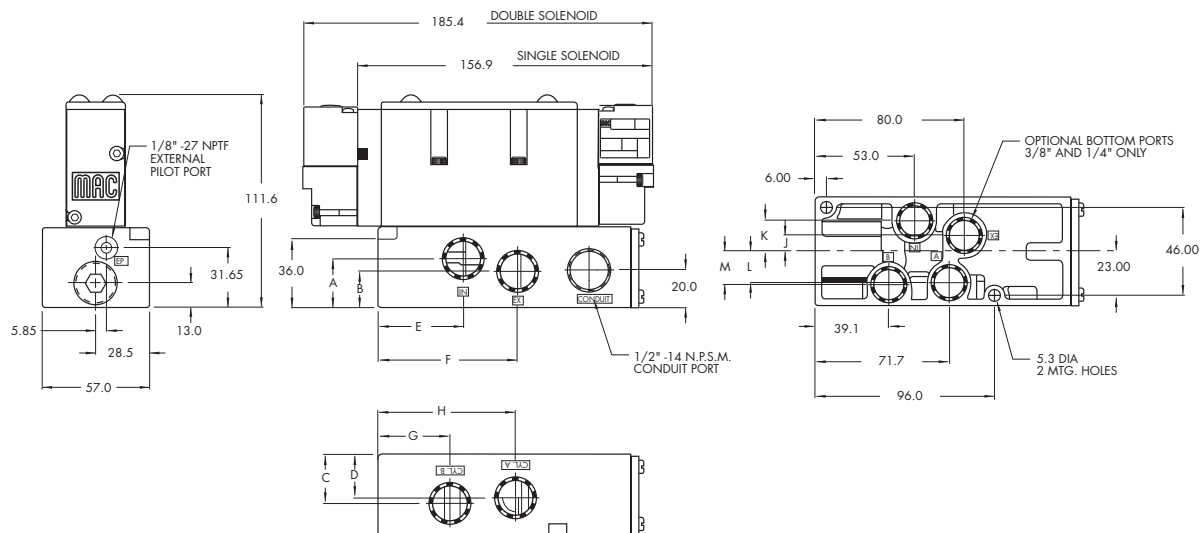

DIM.	A	B	C	D	E	F	G	H	DIM.	J	K	L	M
3/8"	27.15	20.65	27.15	24.15	54.1	81.7	38.2	73.5	1/4"	7.0	14.7	15.0	16.5
1/2"	25.5	19.0	25.5	22.5	45.8	75.3	38.2	73.5	3/8"	8.5	16.2	16.5	17.5



# Direct solenoid and solenoid pilot operated valves

Function	Port size	Flow (Max)	Manifold mounting	Series
<b>5/2, 5/3</b>	<b>3/8" - 1/2"</b>	<b>3.8 C<sub>v</sub></b>	Sub-base non "plug-in"	

### OPERATIONAL BENEFITS

1. Unique patented Macsolenoid® for fastest possible response times and virtually burn-out proof solenoid operation.
2. Balanced poppet 4-way pilot valve provides maximum shifting forces, precise repeatability and consistent operation.
3. Air only return. Optional memory spring is also available.
4. Optional low wattage DC solenoid down to 1 watt.
5. MAC spool and bore combination wipes away contamination, eliminates sticking and allows for use on non-lube service.

### HOW TO ORDER

#### SINGLE PRESSURE MODELS

Port size	Pilot air	5/2 Single operator	5/2 Double operator	5/3 Closed center	5/3 Open center
<b>Valve less base</b>		93A-ABA-000-DM-Dxxx-xxx	93A-BBA-000-DM-Dxxx-xxx	93A-EBA-000-DM-Dxxx-xxx	93A-FBA-000-DM-Dxxx-xxx
<b>3/8" NPTF</b>	Internal	93A-ABA-BJG-DM-Dxxx-xxx	93A-BBA-BJG-DM-Dxxx-xxx	93A-EBA-BJG-DM-Dxxx-xxx	93A-FBA-BJG-DM-Dxxx-xxx
<b>1/2" NPTF</b>		93A-ABA-CJG-DM-Dxxx-xxx	93A-BBA-CJG-DM-Dxxx-xxx	93A-EBA-CJG-DM-Dxxx-xxx	93A-FBA-CJG-DM-Dxxx-xxx
<b>3/8" NPTF</b>	External	93A-ABA-BJH-DM-Dxxx-xxx	93A-BBA-BJH-DM-Dxxx-xxx	93A-EBA-BJH-DM-Dxxx-xxx	93A-FBA-BJH-DM-Dxxx-xxx
<b>1/2" NPTF</b>		93A-ABA-CJH-DM-Dxxx-xxx	93A-BBA-CJH-DM-Dxxx-xxx	93A-EBA-CJH-DM-Dxxx-xxx	93A-FBA-CJH-DM-Dxxx-xxx

#### DUAL PRESSURE MODELS (REQUIRE SANDWICH REGULATOR, SEE „REGULATORS“ SECTION)

Port size	Pilot air	5/2 Single operator	5/2 Double operator	5/3 Pressure center
<b>Valve less base</b>		93A-CBA-000-DM-Dxxx-xxx	93A-DBA-000-DM-Dxxx-xxx	93A-HBA-000-DM-Dxxx-xxx
<b>3/8" NPTF</b>	Internal	93A-CBA-BJG-DM-Dxxx-xxx	93A-DBA-BJG-DM-Dxxx-xxx	93A-HBA-BJG-DM-Dxxx-xxx
<b>1/2" NPTF</b>		93A-CBA-CJG-DM-Dxxx-xxx	93A-DBA-CJG-DM-Dxxx-xxx	93A-HBA-CJG-DM-Dxxx-xxx
<b>3/8" NPTF</b>	External	93A-CBA-BJH-DM-Dxxx-xxx	93A-DBA-BJH-DM-Dxxx-xxx	93A-HBA-BJH-DM-Dxxx-xxx
<b>1/2" NPTF</b>		93A-CBA-CJH-DM-Dxxx-xxx	93A-DBA-CJH-DM-Dxxx-xxx	93A-HBA-CJH-DM-Dxxx-xxx

#### SOLENOID OPERATOR >

DM-D **XXX-XXX\***

Above models are shown with side ports.

XX Voltage	X Wire length	X Manual operator	XX Electrical connection
<b>JA</b> 110/50, 120/60	<b>A</b> 18" (Flying leads)	<b>1</b> Non-locking recessed	<b>BM</b> Flying leads
<b>JB</b> 220/50, 240/60	<b>B</b> 24" (Flying leads)	<b>2</b> Locking recessed	<b>BN</b> Flying leads with diode
<b>JC</b> 24/50, 24/60	<b>J</b> Connector		<b>KA</b> Square connector
<b>FB</b> 24 VDC (1.8W)			<b>KD</b> Square connector with light
<b>DA</b> 24 VDC (5.4W)			
<b>DF</b> 24 VDC (12.7W)			

\* Other options available, see page 309.  
End plate kit required (1/2" ports): M-93001-01-01 internal pilot.  
M-93001-02-01 external pilot.

Other options available for the 93 series valves, see page 169.



33  
34  
36  
32  
37  
38  
52  
67  
69  
44  
46  
42  
47  
48P  
48  
400  
92  
93  
ISO 01  
ISO 02  
ISO 1  
ISO 2  
ISO 3

**TECHNICAL DATA**

<b>Fluid :</b>	Compressed air, vacuum, inert gases
<b>Pressure range :</b>	Internal Pilot: 20 to 120 PSI External Pilot: Vacuum to 120 PSI
<b>Lubrication :</b>	Not required, if used select a medium aniline point lubricant (between 180°F and 210°F)
<b>Filtration :</b>	40 µ
<b>Temperature range :</b>	0°F to 120°F (-18°C to +50°C)
<b>Flow :</b>	3/8" : (3.4 C <sub>v</sub> ) - 1/2" : (3.8 C <sub>v</sub> )
<b>Coil :</b>	Class A continuous duty, #22 AWG x 18 leads
<b>Voltage range :</b>	-15% to +10% of nominal voltage
<b>Protection :</b>	Consult factory
<b>Power :</b>	~ Inrush 7.6 VA    Holding: 4.8 VA = 1 to 12.7 W
<b>Response times : (with 5.4 W coil)</b>	Energize : 13 ms De-energize : 10 ms

- Options :
- BSPP thread • Sandwich regulator (see ,regulators' section)
  - Sandwich flow controls FC93A-BA (screwdriver slot adjustment), FC93A-BB (locking knob adjustment)

- Spare parts :
- Pilot valve: DM-Dxxx-xxx • Valve to base pressure seal: 16622
  - Pilot valve pressure seal: 16542 • Mounting screws valve to base (x4): 35249
  - Inlet/exh. Isolator disc: N-93008 • Valve blanking plate: M-93002

**DIMENSIONS**

Dimensions shown are metric (mm)

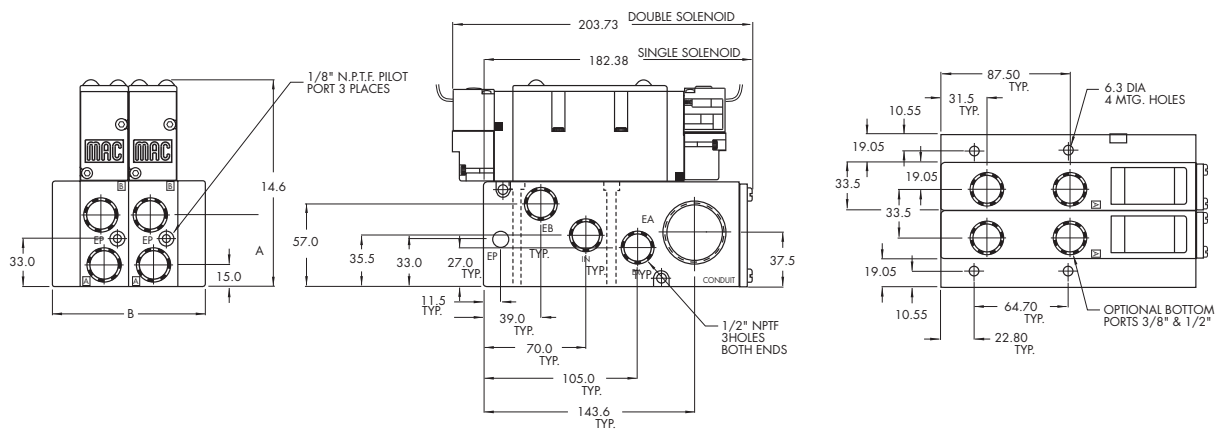

#	1	2	3	4	5	6	7	8	9	10
<b>B</b>	71.6	105.1	138.6	172.1	205.6	239.1	272.6	306.1	339.6	373.1

<b>DIM.</b>	<b>A</b>
<b>3/8"</b>	47.66
<b>1/2"</b>	49.32



# Direct solenoid and solenoid pilot operated valves

Function	Port size	Flow (Max)	Manifold mounting	Series
<b>5/2, 5/3</b>	<b>3/8" - 1/2"</b>	<b>3.8 C<sub>v</sub></b>	Sub-base "plug-in"	

### OPERATIONAL BENEFITS

1. Unique patented Macsolenoid® for fastest possible response times and virtually burn-out proof solenoid operation.
2. Balanced poppet 4-way pilot valve provides maximum shifting forces, precise repeatability and consistent operation.
3. Air only return. Optional memory spring is also available.
4. Optional low wattage DC solenoid down to 1 watt.
5. MAC spool and bore combination wipes away contamination, eliminates sticking and allows for use on non-lube service.



### HOW TO ORDER

#### SINGLE PRESSURE MODELS

Port size	Pilot air	5/2 Single operator	5/2 Double operator	5/3 Closed center	5/3 Open center
<b>Valve less base</b>		93A-AAA-000-DM-DxxP-xxx	93A-BAA-000-DM-DxxP-xxx	93A-EAA-000-DM-DxxP-xxx	93A-FAA-000-DM-DxxP-xxx
<b>3/8" NPTF</b>	Internal	93A-AAA-BJA-DM-DxxP-xxx	93A-BAA-BJA-DM-DxxP-xxx	93A-EAA-BJA-DM-DxxP-xxx	93A-FAA-BJA-DM-DxxP-xxx
<b>1/2" NPTF</b>		93A-AAA-CJA-DM-DxxP-xxx	93A-BAA-CJA-DM-DxxP-xxx	93A-EAA-CJA-DM-DxxP-xxx	93A-FAA-CJA-DM-DxxP-xxx
<b>3/8" NPTF</b>	External	93A-AAA-BJD-DM-DxxP-xxx	93A-BAA-BJD-DM-DxxP-xxx	93A-EAA-BJD-DM-DxxP-xxx	93A-FAA-BJD-DM-DxxP-xxx
<b>1/2" NPTF</b>		93A-AAA-CJD-DM-DxxP-xxx	93A-BAA-CJD-DM-DxxP-xxx	93A-EAA-CJD-DM-DxxP-xxx	93A-FAA-CJD-DM-DxxP-xxx

#### DUAL PRESSURE MODELS (REQUIRE SANDWICH REGULATOR, SEE "REGULATORS" SECTION)

Port size	Pilot air	5/2 Single operator	5/2 Double operator	5/3 Pressure Center
<b>Valve less base</b>		93A-CAA-000-DM-DxxP-xxx	93A-DAA-000-DM-DxxP-xxx	93A-HAA-000-DM-DxxP-xxx
<b>3/8" NPTF</b>	Internal	93A-CAA-BJA-DM-DxxP-xxx	93A-DAA-BJA-DM-DxxP-xxx	93A-HAA-BJA-DM-DxxP-xxx
<b>1/2" NPTF</b>		93A-CAA-CJA-DM-DxxP-xxx	93A-DAA-CJA-DM-DxxP-xxx	93A-HAA-CJA-DM-DxxP-xxx
<b>3/8" NPTF</b>	External	93A-CAA-BJD-DM-DxxP-xxx	93A-DAA-BJD-DM-DxxP-xxx	93A-HAA-BJD-DM-DxxP-xxx
<b>1/2" NPTF</b>		93A-CAA-CJD-DM-DxxP-xxx	93A-DAA-CJD-DM-DxxP-xxx	93A-HAA-CJD-DM-DxxP-xxx

#### SOLENOID OPERATOR ►

DM-D **XX** P-**XXX**\*

Above model numbers are shown with side ports without light.

XX Voltage	X Manual operator	XX Electrical connection
<b>JA</b> 110/50, 120/60 (2.9W)	<b>1</b> Non-locking recessed	<b>DM</b> Plug-in
<b>JB</b> 220/50, 240/60 (2.9W)	<b>2</b> Locking recessed	<b>DN</b> Plug-in with diode
<b>JC</b> 24/50, 24/60 (2.9W)		<b>DP</b> Plug-in with M.O.V.
<b>FB</b> 24 VDC (1.8W)		<b>DG</b> Plug-in with ground
<b>DA</b> 24 VDC (5.4W)		
<b>DF</b> 24 VDC (12.7W)		

\* Other options available, see page 309.  
 End plate required (1/2" ports): M-93001-01-01 Internal pilot.  
 M-93001-02-01 External pilot.  
 Other options available for the 93 series valves, see page 170.

33  
34  
36  
32  
37  
38  
52  
67  
69  
44  
46  
42  
47  
48P  
48  
400  
92  
93  
ISO 01  
ISO 02  
ISO 1  
ISO 2  
ISO 3

**TECHNICAL DATA**

<b>Fluid :</b>	Compressed air, vacuum, inert gases
<b>Pressure range :</b>	Internal Pilot: 20 to 120 PSI External Pilot: Vacuum to 120 PSI
<b>Lubrication :</b>	Not required, if used select a medium aniline point lubricant (between 180°F and 210°F)
<b>Filtration :</b>	40 µ
<b>Temperature range :</b>	0°F to 120°F (-18°C to +50°C)
<b>Flow :</b>	3/8" : (3.4 C <sub>v</sub> ) - 1/2" : (3.8 C <sub>v</sub> )
<b>Coil :</b>	Class A continuous duty, #22 AWG x 18 base leads
<b>Voltage range :</b>	-1.5% to +10% of nominal voltage
<b>Protection :</b>	Consult factory
<b>Power :</b>	~ Inrush 7.6 VA    Holding: 4.8 VA = 1 to 12.7 W
<b>Response times : (with 5.4 W coil)</b>	Energize : 13 ms De-energize : 10 ms

Options :  

- BSPP thread • Sandwich regulator (see ,regulators' section)
- Sandwich flow controls FC93A-AA (screwdriver slot adjustment), FC93A-AB (locking knob adjustment)

Spare parts :  

- Pilot valve: DM-DxxP-xxx • Valve to base pressure seal: 16622
- Pilot valve pressure seal: 16542 • Mounting screws valve to base (x4): 35249
- Inlet/exh. Isolator disc: N-93008 • Valve blanking plate: M-93002

**DIMENSIONS**

Dimensions shown are metric (mm)

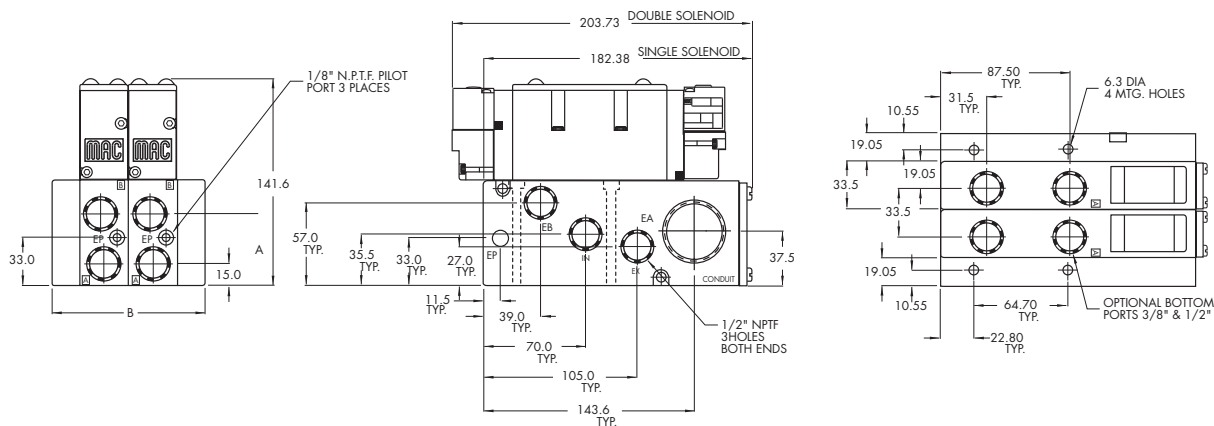

#	1	2	3	4	5	6	7	8	9	10
<b>B</b>	71.6	105.1	138.6	172.1	205.6	239.1	272.6	306.1	339.6	373.1

DIM.	A
<b>3/8"</b>	47.66
<b>1/2"</b>	49.32

<b>OPTIONS FOR NON PLUG-IN AND INLINE VALVES</b>	<b>33</b>
	<b>34</b>
<b>Valve function</b>	<b>36</b>
93A-LXX-XXX-XX-Dxxx-xxx	
<ul style="list-style-type: none"> <li><b>L</b> for single operator, single pressure with memory spring</li> <li><b>N</b> for single operator, dual pressure with memory spring</li> <li><b>R</b> for single operator universal spool (ext. pilot only)</li> <li><b>S</b> for double operator universal spool (ext. pilot only)</li> </ul>	<b>32</b>
	<b>37</b>
<b>Pilot exhaust</b>	<b>38</b>
93A-XXB-XXX-XX-Dxxx-xxx	<b>52</b>
<ul style="list-style-type: none"> <li><b>B</b> standard pilot exhaust</li> <li><b>D</b> pilot exhaust to main valve exhaust*</li> </ul>	<b>67</b>
	<b>69</b>
	<b>44</b>
<b>Port configuration :</b>	<b>46</b>
<b>Individual sub-base</b>	
93A-XXX-XAX-XX-Dxxx-xxx	
<ul style="list-style-type: none"> <li><b>A</b> side ports (3/8" &amp; 1/2" only)</li> <li><b>B</b> bottom ports (1/4" &amp; 3/8" only)</li> <li><b>C</b> side &amp; bottom ports (1/4" &amp; 3/8" only)</li> <li><b>D</b> side inlet &amp; exhaust with bottom cylinder ports (1/4" &amp; 3/8" only)</li> </ul>	<b>42</b>
	<b>47</b>
	<b>48P</b>
<b>Pilot style :</b>	<b>48</b>
93A-XXX-XXX-DM-Dxxx-xxx	
<ul style="list-style-type: none"> <li><b>DM</b> pilot exhaust muffled</li> <li><b>DP</b> pilot exhaust piped (#10-32)</li> <li><b>DU</b> pilot exhaust to main exhaust</li> </ul>	<b>400</b>
<b>Base only :</b>	<b>92</b>
93A-000-XXX (i.e. 93A-000-BAG) - Individual base	93A-000-XXX (i.e. 93A-000-BJG) - Manifold base

\* Must use DU pilot. Main valve exhaust cannot be restricted.



# Direct solenoid and solenoid pilot oper

## OPTIONS FOR PLUGIN VALVES

### Valve function

93A- LXX-XXX-XX-D xx P-xxx

- L for single operator, single pressure with memory spring
- N for single operator, dual pressure with memory spring
- R for single operator universal spool (ext. pilot only)
- S for double operator universal spool (ext. pilot only)

### Pilot exhaust

93A-X A X-XXX-XX-D xx P-xxx

- A standard pilot exhaust
- C pilot exhaust to main valve exhaust\*

### Body electrical

93A-XX A -XXX-XX-D xx P-xxx

- A no light
- B light(s)

### Port configuration :

#### Individual sub-base

93A-XXX-X A X-XX-D xx P-xxx

- A side ports (3/8" & 1/2" only)
- B bottom ports (1/4" & 3/8" only)
- C side & bottom ports (1/4" & 3/8" only)
- D side inlet & exhaust with bottom cylinder ports (1/4" & 3/8" only)

#### Manifold sub-base

93A-XXX-X JX-XX-D xx P-xxx

- J side ports
- K bottom ports

### Base/manifold int./ext. pilot

93A-XXX-XX A -XX-D xx P-xxx

- A internal pilot no light
- B internal pilot single light
- C internal pilot double light
- D external pilot no light
- E external pilot single light
- F external pilot double light

### Pilot style :

93A-XXX-XXX- DM -D xx P-xxx

- DM pilot exhaust muffled
- DP pilot exhaust piped (#10-32)
- DU pilot exhaust to main exhaust

### Base only :

93A-000-XXX (i.e. 93A-000-BAA) - Individual base  
(Note: bases are wired for double solenoid valves)

93A-000-XXX (i.e. 93A-000-BJA) - Manifold base

\* Must use DU pilot. Main valve exhaust cannot be restricted.



Individual mounting	Series
Valve only - No base non "plug-in" Conform to ISO 15407/1	33
Valve only - No base non "plug-in" Conform to ISO 15407/1	34
Valve only - No base non "plug-in" Conform to ISO 15407/1	36
Valve only - No base non "plug-in" Conform to ISO 15407/1	32
Valve only - No base non "plug-in" Conform to ISO 15407/1	37
Valve only - No base non "plug-in" Conform to ISO 15407/1	38
Valve only - No base non "plug-in" Conform to ISO 15407/1	52
Valve only - No base non "plug-in" Conform to ISO 15407/1	67
Valve only - No base non "plug-in" Conform to ISO 15407/1	69
Valve only - No base non "plug-in" Conform to ISO 15407/1	44
Valve only - No base non "plug-in" Conform to ISO 15407/1	46
Valve only - No base non "plug-in" Conform to ISO 15407/1	42
Valve only - No base non "plug-in" Conform to ISO 15407/1	47
Valve only - No base non "plug-in" Conform to ISO 15407/1	48P
Valve only - No base non "plug-in" Conform to ISO 15407/1	48
Valve only - No base non "plug-in" Conform to ISO 15407/1	400
Valve only - No base non "plug-in" Conform to ISO 15407/1	92
Valve only - No base non "plug-in" Conform to ISO 15407/1	93
Valve only - No base non "plug-in" Conform to ISO 15407/1	<b>ISO 01</b>
Valve only - No base non "plug-in" Conform to ISO 15407/1	ISO 02
Valve only - No base non "plug-in" Conform to ISO 15407/1	ISO 1
Valve only - No base non "plug-in" Conform to ISO 15407/1	ISO 2
Valve only - No base non "plug-in" Conform to ISO 15407/1	ISO 3

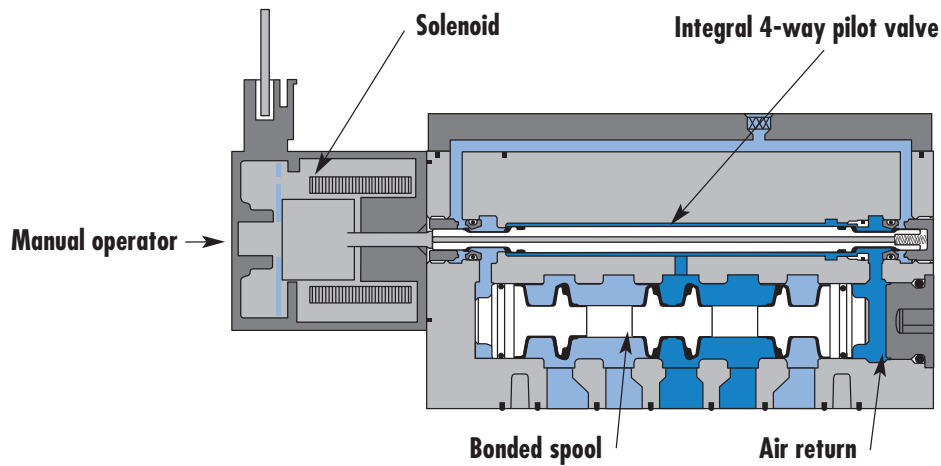

**SERIES FEATURES**

- High force MACSOLENOID®.
- Integral 4-way pilot design.
- 2-position, single or double operator.
- 3-position, double solenoid, open center, closed center and pressure center.
- Internal or external pilot.
- Single or dual pressure.

Function	Port size	Flow (Max)	Individual/Manifold mounting	Series
<b>5/2, 5/3</b>	<b>1/4"</b>	<b>1.0 C<sub>v</sub></b>	Valve only - No base non "plug-in" Conform to ISO 15407/1	

### OPERATIONAL BENEFITS

1. Unique patented MACsolenoid® with oval shaped armature for fastest possible response times.
2. Balanced poppet 4-way pilot valve provides maximum shifting forces, precise repeatability and consistent operation.
3. MAC spool and bore combination wipes away contamination, eliminates sticking and allows for use on non-lube service.
4. Large spool area for maximum shifting forces even at minimum operating pressure.
5. Very high flow in a compact package. Pilot valve and main valve in the same body.
6. Internal or external pilot operation.
7. Air only return
8. Optional low wattage DC solenoid down to 1.0 Watt.



### HOW TO ORDER

#### SINGLE PRESSURE MODELS

Pilot air	5/2 Single operator	5/2 Double operator	5/3 Closed center	5/3 Open center
Internal	MV-A01A-AAMA-Jxxx-xxx	MV-A01A-ABMA-Jxxx-xxx	MV-A01A-AEMA-Jxxx-xxx	MV-A01A-AFMA-Jxxx-xxx
External "12" end	MV-A01A-AAMD-Jxxx-xxx	MV-A01A-ABMD-Jxxx-xxx	MV-A01A-AEMD-Jxxx-xxx	MV-A01A-AFMD-Jxxx-xxx
External "14" end	MV-A01A-AAME-Jxxx-xxx	MV-A01A-ABME-Jxxx-xxx	MV-A01A-AEME-Jxxx-xxx	MV-A01A-AFME-Jxxx-xxx

#### DUAL PRESSURE MODELS

Pilot air	5/2 Single operator	5/2 Double operator	5/3 Pressure center
Internal from port #3	MV-A01A-ACMB-Jxxx-xxx	MV-A01A-ADMB-Jxxx-xxx	MV-A01A-AHMB-Jxxx-xxx
Internal from port #5	MV-A01A-ACMC-Jxxx-xxx	MV-A01A-ADMC-Jxxx-xxx	MV-A01A-AHMC-Jxxx-xxx
External from "12" end	MV-A01A-ACMD-Jxxx-xxx	MV-A01A-ADMD-Jxxx-xxx	MV-A01A-AHMD-Jxxx-xxx
External from "14" end	MV-A01A-ACME-Jxxx-xxx	MV-A01A-ADME-Jxxx-xxx	MV-A01A-AHME-Jxxx-xxx

#### SOLENOID OPERATOR ▶

**J XXX-XXX\***

XX Voltage	X Lead wire length	X Manual operator	XX Electrical connection
<b>DA</b> 24 VDC (5.4W)	<b>0</b> No lead wire/ connector	<b>1</b> Non-locking	<b>BA</b> Flying leads
<b>DB</b> 12 VDC (5.4W)	<b>A</b> 18"	<b>2</b> Locking	<b>JA</b> Square connector
<b>DC</b> 24 VDC (2.4W)	<b>B</b> 24"		<b>JC</b> Square connector with light
<b>DD</b> 12 VDC (2.4W)	<b>C</b> 36"		<b>JB</b> Rectangular connector
<b>DE</b> 24 VDC (1.8W)			<b>JD</b> Rectangular connector with light
<b>DU</b> 24 VDC (1.0W)			<b>KA</b> Mini square connector
			<b>KD</b> Mini square connector with light

\* Other options available, see page 317.

Note: - ISO series, valve and base are ordered separately, see page 227 for base codes.  
- If sandwich regulator is required, valve must be ordered as external pilot. For internal pilot regulator use valve with external pilot 12 end, - for external pilot regulator, use valve with external pilot 12 or 14 end.

### OPTIONS

Pilot exhaust: **MV-A01A-XX X X-Jxxx-xxx**

- M** Pilot exhaust muffled
- P** Pilot exhaust piped #10-32
- U** Pilot exhaust out main exhaust

33  
34  
36  
32  
37  
38  
52  
67  
69  
44  
46  
42  
47  
48P  
48  
400  
92  
93

**ISO 01**  
**ISO 02**  
**ISO 1**  
**ISO 2**  
**ISO 3**

**TECHNICAL DATA**

<b>Fluid :</b>	Compressed air, vacuum, inert gases
<b>Pressure range :</b>	Internal Pilot - 2 pos.: 20 to 120 PSI - 3 pos.: 35 to 120 PSI External Pilot: Vacuum to 120 PSI
<b>Pilot pressure :</b>	2 pos.: 20 to 120 PSI - 3 pos.: 35 to 120 PSI
<b>Lubrication :</b>	Not required, if used select a medium aniline point lubricant (between 180°F and 210°F)
<b>Filtration :</b>	40 µ
<b>Temperature range :</b>	0°F to 120°F (-18°C to +50°C)
<b>Flow :</b>	2 pos.: Cv 1.0 – 3 pos.: Cv 0.8
<b>Coil :</b>	Class A wires continuous duty, #22 AWG x 18
<b>Voltage range :</b>	-1.5% to +10% of nominal voltage
<b>Power :</b>	1,0 to 5,4 W

- Options :
- Sandwich flow controls: FCA01A-AA (screwdriver slot adjustment).
  - Sandwich pressure regulator, see ,Regulators' section

**DIMENSIONS**

**Individual base**

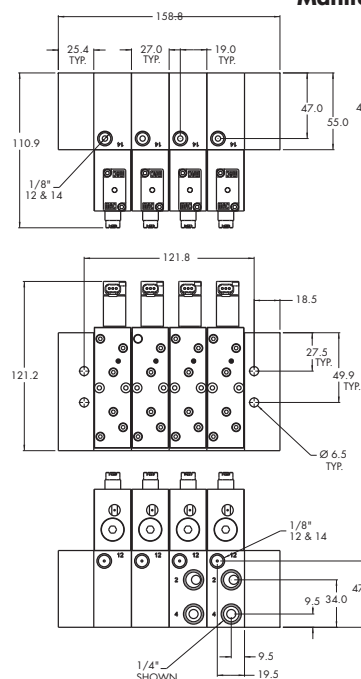

Dimensions shown are metric (mm)

**Manifold base**

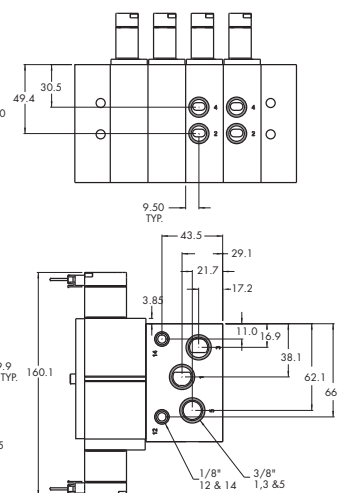

Individual mounting	Series
Valve only - No base non "plug-in" Conform to ISO 15407/1	33
Valve only - No base non "plug-in" Conform to ISO 15407/1	34
Valve only - No base non "plug-in" Conform to ISO 15407/1	36
Valve only - No base non "plug-in" Conform to ISO 15407/1	32
Valve only - No base non "plug-in" Conform to ISO 15407/1	37
Valve only - No base non "plug-in" Conform to ISO 15407/1	38
Valve only - No base non "plug-in" Conform to ISO 15407/1	52
Valve only - No base non "plug-in" Conform to ISO 15407/1	67
Valve only - No base non "plug-in" Conform to ISO 15407/1	69
Valve only - No base non "plug-in" Conform to ISO 15407/1	44
Valve only - No base non "plug-in" Conform to ISO 15407/1	46
Valve only - No base non "plug-in" Conform to ISO 15407/1	42
Valve only - No base non "plug-in" Conform to ISO 15407/1	47
Valve only - No base non "plug-in" Conform to ISO 15407/1	48P
Valve only - No base non "plug-in" Conform to ISO 15407/1	48
Valve only - No base non "plug-in" Conform to ISO 15407/1	400
Valve only - No base non "plug-in" Conform to ISO 15407/1	92
Valve only - No base non "plug-in" Conform to ISO 15407/1	93
Valve only - No base non "plug-in" Conform to ISO 15407/1	ISO 01
Valve only - No base non "plug-in" Conform to ISO 15407/1	<b>ISO 02</b>
Valve only - No base non "plug-in" Conform to ISO 15407/1	ISO 1
Valve only - No base non "plug-in" Conform to ISO 15407/1	ISO 2
Valve only - No base non "plug-in" Conform to ISO 15407/1	ISO 3

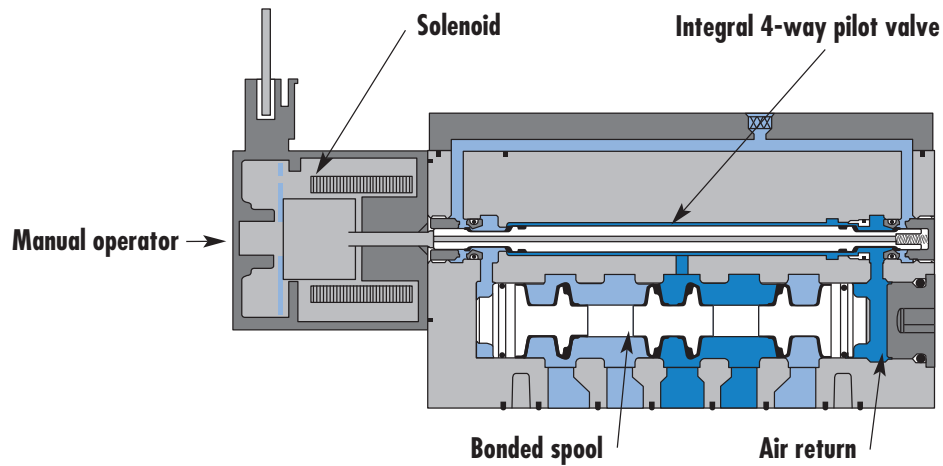

**SERIES FEATURES**

- High force MACSOLENOID®.
- Integral 4-way pilot design.
- 2-position, single or double operator.
- 3-position, double solenoid, open center, closed center and pressure center.
- Internal or external pilot.
- Single or dual pressure.

Function	Port size	Flow (Max)	Individual/Manifold mounting	Series
<b>5/2, 5/3</b>	<b>1/8"</b>	<b>0.43 C<sub>v</sub></b>	Valve only - No base non "plug-in" Conform to ISO 15407/1	

### OPERATIONAL BENEFITS

1. Unique patented MACsolenoid® with oval shaped armature for fastest possible response times.
2. Balanced poppet 4-way pilot valve provides maximum shifting forces, precise repeatability and consistent operation.
3. MAC spool and bore combination wipes away contamination, eliminates sticking and allows for use on non-lube service.
4. Large spool area for maximum shifting forces even at minimum operating pressure.
5. Very high flow in a compact package. Pilot valve and main valve in the same body.
6. Internal or external pilot operation.
7. Air only return
8. Optional low wattage DC solenoid down to 1.0 Watt.



33  
34  
36  
32  
37  
38  
52  
67  
69  
44

### HOW TO ORDER

#### SINGLE PRESSURE MODELS

Pilot air	5/2 Single operator	5/2 Double operator	5/3 Closed center	5/3 Open center
Internal	MV-A02A-AAMA-Jxxx-xxx	MV-A02A-ABMA-Jxxx-xxx	MV-A02A-AEMA-Jxxx-xxx	MV-A02A-AFMA-Jxxx-xxx
External "12" end	MV-A02A-AAMD-Jxxx-xxx	MV-A02A-ABMD-Jxxx-xxx	MV-A02A-AEMD-Jxxx-xxx	MV-A02A-AFMD-Jxxx-xxx
External "14" end	MV-A02A-AAME-Jxxx-xxx	MV-A02A-ABME-Jxxx-xxx	MV-A02A-AEME-Jxxx-xxx	MV-A02A-AFME-Jxxx-xxx

46  
42  
47  
48P

#### DUAL PRESSURE MODELS

Pilot air	5/2 Single operator	5/2 Double operator	5/3 Pressure center
Internal from port #3	MV-A02A-ACMB-Jxxx-xxx	MV-A02A-ADMB-Jxxx-xxx	MV-A02A-AHMB-Jxxx-xxx
Internal from port #5	MV-A02A-ACMC-Jxxx-xxx	MV-A02A-ADMC-Jxxx-xxx	MV-A02A-AHMC-Jxxx-xxx
External from "12" end	MV-A02A-ACMD-Jxxx-xxx	MV-A02A-ADMD-Jxxx-xxx	MV-A02A-AHMD-Jxxx-xxx
External from "14" end	MV-A02A-ACME-Jxxx-xxx	MV-A02A-ADME-Jxxx-xxx	MV-A02A-AHME-Jxxx-xxx

48  
400  
92  
93

#### SOLENOID OPERATOR ▶

J **XXX-XXX**\*

XX	Voltage	X	Lead wire length	X	Manual operator	XX	Electrical connection
DA	24V=/5,4W	0	No lead wire/ connector	1	Non-locking	BA	Flying leads
DB	12V=/5,4W	A	45 cm	2	Locking	JA	Square connector
DC	24V=/2,4W	B	60 cm			JC	Square connector with light
DD	12V=/2,4W	C	90 cm			JB	Rectangular connector
DE	24V=/1,8W					JD	Rectangular connector with light
DU	24V=/1,0W					KA	Mini square connector
						KD	Mini square connector with light

ISO 01  
**ISO 02**  
ISO 1  
ISO 2  
ISO 3

\* Other options available, see page 317.

Note: - ISO series, valve and base are ordered separately, see page 229 for base codes.  
- If sandwich regulator is required, valve must be ordered as external pilot. For internal pilot regulator use valve with external pilot 12 end, - for external pilot regulator, use valve with external pilot 12 or 14 end.

### OPTIONS

Pilot exhaust: MV-A02A-XX **X** X-Jxxx-xxx

- M** Pilot exhaust muffled
- P** Pilot exhaust piped #10-32
- U** Pilot exhaust out main exhaust

**TECHNICAL DATA**

<b>Fluid :</b>	Compressed air, vacuum, inert gases
<b>Pressure range :</b>	Internal Pilot - 2 pos.: 20 to 120 PSI - 3 pos.: 35 to 120 PSI External Pilot: Vacuum to 120 PSI
<b>Pilot pressure :</b>	2 pos.: 20 to 120 PSI - 3 pos.: 35 to 120 PSI
<b>Lubrication :</b>	Not required, if used select a medium aniline point lubricant (between 180°F and 210°F)
<b>Filtration :</b>	40 µ
<b>Temperature range :</b>	0°F to 120°F (-18°C to +50°C)
<b>Flow :</b>	2 pos.: Cv 0.43 – 3 pos.: Cv 0.28
<b>Coil :</b>	Class A wires continuous duty, #22 AWG x 18
<b>Voltage range :</b>	-1.5% to +10% of nominal voltage
<b>Power :</b>	1,0 to 5,4 W

- Options :
- Sandwich flow controls: FCA02A-AA (screwdriver slot adjustment).
  - Sandwich pressure regulator, see ,Regulators' section

**DIMENSIONS**

**Individual base**

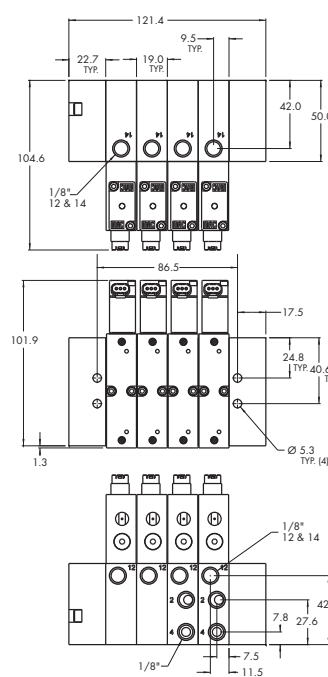

Dimensions shown are metric (mm)

**Manifold base**

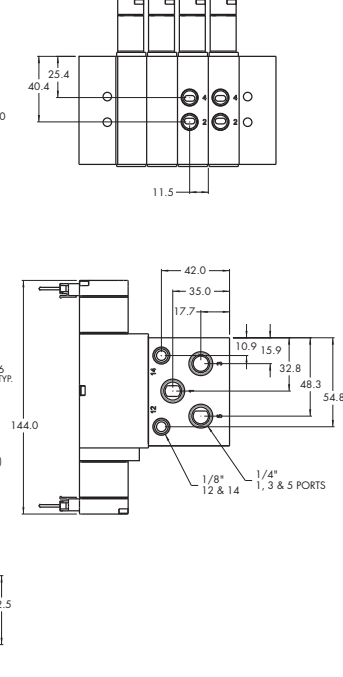

Individual mounting		Series
Valve only - No base non "plug-in" Conform to ISO 5599/1	Valve only - No base "plug-in" Conform to ISO 5599/2	33
Manifold mounting		34
Valve only - No base non "plug-in" Conform to ISO 5599/1	Valve only - No base "plug-in" Conform to ISO 5599/2	36
		32
		37
		38
		52
		67
		69
		44
		46
		42
		47
		48P
		48
		400
		92
		93
		ISO 01
		ISO 02
		<b>ISO 1</b>
		ISO 2
		ISO 3

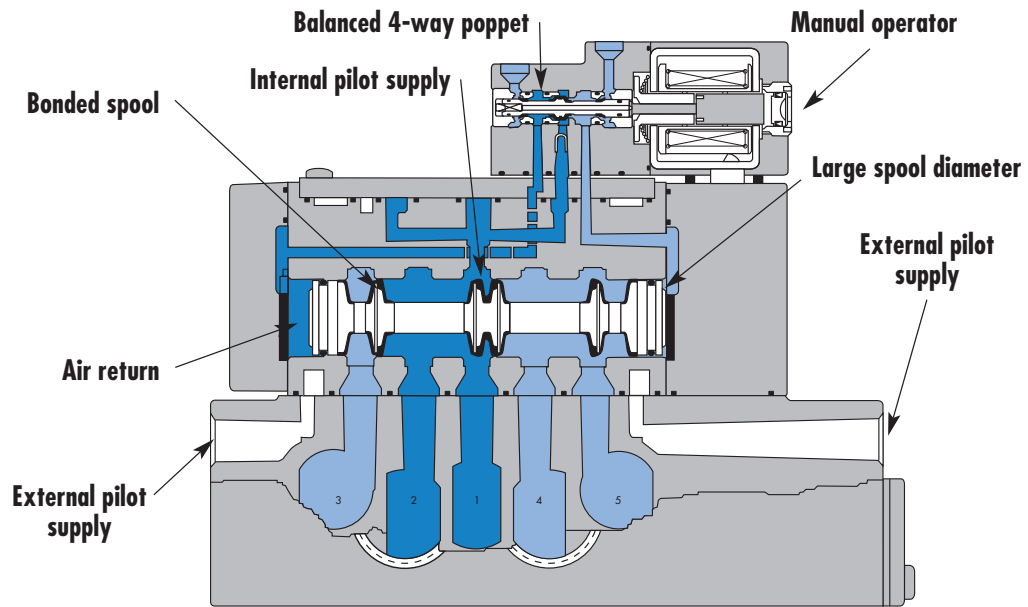

**SERIES FEATURES**

- Plug-in (5599/2) and non plug-in (5599/1) models.
- 2-position, single or double operator. (Solenoid or Remote Air)
- 3-position, double solenoid, open center, closed center, and pressure center.
- Extended or recessed manual operators.
- Single pressure and dual pressure.
- Individual base or add-a-unit manifold base.
- Plug-in, sandwich, single and dual pressure regulators for both individual and manifold valves.

Function	Port size	Flow (Max)	Individual/Manifold mounting	Series
<b>5/2, 5/3</b>	<b>1/4" - 3/8"</b>	<b>1.8 C<sub>v</sub></b>	Valve only - No base non "plug-in" Conform to ISO 5599/1	

### OPERATIONAL BENEFITS

1. Unique patented Macsolenoid® for fastest possible response times and virtually burn-out proof AC solenoid operation.
2. Balanced poppet 4-way pilot valve provides maximum shifting forces, precise repeatability and consistent operation.
3. MAC spool and bore combination wipes away contamination, eliminates sticking and allows for use on non-lube service.
4. Large spool area for maximum shifting forces even at minimum operating pressure.
5. Very high flow in a compact package.
6. Plug-in design of valves, bases and regulators for modular assembly and ease of maintenance.
7. Internal or external pilot operation. Manifolds supplied with common external pilot.
8. Air only return. Optional memory spring is also available.
9. Optional low wattage DC solenoid down to 1.0 watt.



### HOW TO ORDER

#### SINGLE PRESSURE MODELS

Pilot air	5/2 Single operator	5/2 Double operator	5/3 Closed center	5/3 Open center
Internal	MV-B1A-AAAA-DM-Dxxx-xxx	MV-B1A-ABAA-DM-Dxxx-xxx	MV-B1A-AEAA-DM-Dxxx-xxx	MV-B1A-AFAA-DM-Dxxx-xxx
External "12" end	MV-B1A-AAAB-DM-Dxxx-xxx	MV-B1A-ABAB-DM-Dxxx-xxx	MV-B1A-AEAB-DM-Dxxx-xxx	MV-B1A-AFAB-DM-Dxxx-xxx

#### DUAL PRESSURE MODELS

Pilot air	5/2 Single operator	5/2 Double operator	5/3 Pressure center
Internal pilot From port #3	MV-B1A-ACAD-DM-Dxxx-xxx	MV-B1A-ADAD-DM-Dxxx-xxx	MV-B1A-AGAD-DM-Dxxx-xxx
Internal pilot From port #5	MV-B1A-ACAE-DM-Dxxx-xxx	MV-B1A-ADAE-DM-Dxxx-xxx	MV-B1A-AGAE-DM-Dxxx-xxx
External pilot From "12" end	MV-B1A-ACAB-DM-Dxxx-xxx	MV-B1A-ADAB-DM-Dxxx-xxx	MV-B1A-AGAB-DM-Dxxx-xxx

#### SOLENOID OPERATOR ▶

### DM-D XXX-XXX\*

XX Voltage	X Lead wire length	X Manual operator	XX Electrical connection
<b>JA</b> 110/50, 120/60	<b>A</b> 18" (Flying leads)	<b>1</b> Non-locking recessed	<b>KA</b> Square connector
<b>JB</b> 220/50, 240/60	<b>B</b> 24" (Flying leads)	<b>2</b> Locking recessed	<b>KD</b> Square connector with light
<b>JC</b> 24/50, 24/60	<b>J</b> Connector		<b>JB</b> Rectangular connector
<b>FB</b> 24 VDC (1.8W)			<b>JD</b> Rectangular connector with light
<b>DA</b> 24 VDC (5.4W)			<b>BA</b> Flying leads
<b>DF</b> 24 VDC (12.7W)			

\* Other options available, see page 309.

Note: ISO series, valve and base are ordered separately, see page 231 for base code.

### OPTIONS

Valve function :

MV-B1A-**A**XXX-**XX**-Dxxx-xxx

- J** for single operator universal spool (ext. pilot only)
- K** for double operator universal spool (ext. pilot only)

Pilot style :

MV-B1A-**A**XXX-**DM**-Dxxx-xxx

- DM** Pilot exhaust muffled
- DP** Pilot exhaust piped (#10-32)

Spool return :

MV-B1A-**A**XX-**XX**-Dxxx-xxx

- A** Standard return
- B** Memory spring return

33  
34  
36  
32  
37  
38  
52  
67  
69  
44  
46  
42  
47  
48P  
48  
400  
92  
93  
ISO 01  
ISO 02  
ISO 1  
ISO 2  
ISO 3



**TECHNICAL DATA**

<b>Fluid :</b>	Compressed air, vacuum, inert gases
<b>Pressure range :</b>	Internal pilot: 20 to 120 PSI External pilot : vacuum to 120 PSI
<b>Pilot pressure :</b>	Single/double operator : 20 to 120 PSI, 3 positions : 30 to 120 PSI
<b>Lubrication :</b>	Not required, if used select a medium aniline point lubricant (between 180°F and 210°F)
<b>Filtration :</b>	40 $\mu$
<b>Temperature range :</b>	0°F to 120°F (-18°C to +50°C)
<b>Flow :</b>	3/8": (1.8 C <sub>v</sub> ) – 1/4": (1.6 C <sub>v</sub> )
<b>Coil :</b>	Class A continuous duty, #22 AWG x 18 leads
<b>Voltage range :</b>	-1.5% to +10% of nominal voltage
<b>Protection :</b>	Consult factory
<b>Power :</b>	~ Inrush 7.6 VA    Holding: 4.8 VA = 1 to 12.7 W
<b>Response times : (with 5,4 W coil)</b>	Energize : 11.3 ms De-energize : 7.8 ms

- Options :
- Sandwich flow controls: FCP1A-BA (screwdriver slot adjustment)  
FCP1A-BB (locking knob adjustment)
  - Sandwich regulator, see „Regulators’ section

- Spare parts :
- Pilot valve: DMB-Dxxx-xxx • Valve to base pressure seal: 16661

**DIMENSIONS**

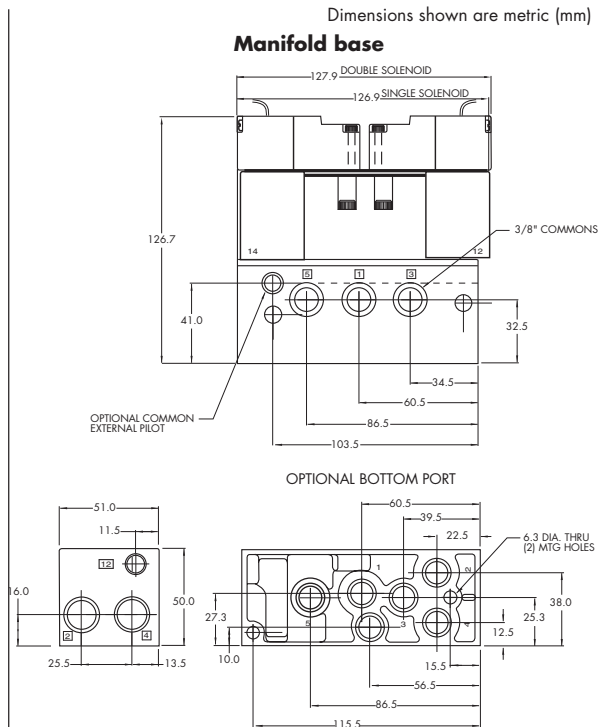
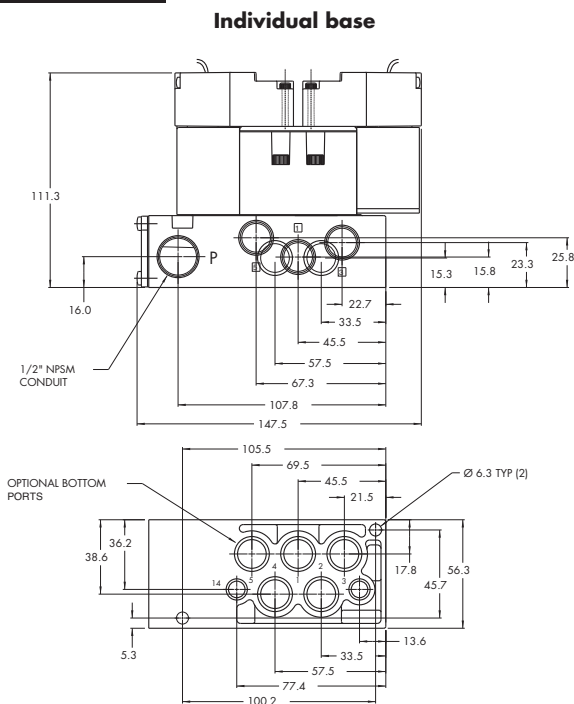

Function	Port size	Flow (Max)	Individual/Manifold mounting	Series
<b>5/2, 5/3</b>	<b>1/4" - 3/8"</b>	<b>1.8 C<sub>v</sub></b>	Valve only - No base "plug-in" Conform to ISO 5599/2	

### OPERATIONAL BENEFITS

1. Unique patented Macsolenoid® for fastest possible response times and virtually burn-out proof AC solenoid operation.
2. Balanced poppet 4-way pilot valve provides maximum shifting forces, precise repeatability and consistent operation.
3. MAC spool and bore combination wipes away contamination, eliminates sticking and allows for use on non-lube service.
4. Large spool area for maximum shifting forces even at minimum operating pressure.
5. Very high flow in a compact package.
6. Plug-in design of valves, bases and regulators for modular assembly and ease of maintenance.
7. Internal or external pilot operation. Manifolds supplied with common external pilot.
8. Air only return. Optional memory spring is also available.
9. Optional low wattage DC solenoid down to 1.0 watt.



### HOW TO ORDER

#### SINGLE PRESSURE MODELS

Pilot air	5/2 Single operator	5/2 Double operator	5/3 Closed center	5/3 Open center
Internal	MV-P1A-AAAA-DM-DxxP-xxx	MV-P1A-ABAA-DM-DxxP-xxx	MV-P1A-AEAA-DM-DxxP-xxx	MV-P1A-AFAA-DM-DxxP-xxx
External "12" end	MV-P1A-AAAB-DM-DxxP-xxx	MV-P1A-ABAB-DM-DxxP-xxx	MV-P1A-AEAB-DM-DxxP-xxx	MV-P1A-AFAB-DM-DxxP-xxx

#### DUAL PRESSURE MODELS

Pilot air	5/2 Single operator	5/2 Double operator	5/3 Pressure center
Internal pilot From port #3	MV-P1A-ACAD-DM-DxxP-xxx	MV-P1A-ADAD-DM-DxxP-xxx	MV-P1A-AGAD-DM-DxxP-xxx
Internal pilot From port #5	MV-P1A-ACAE-DM-DxxP-xxx	MV-P1A-ADAE-DM-DxxP-xxx	MV-P1A-AGAE-DM-DxxP-xxx
External pilot From "12" end	MV-P1A-ACAB-DM-DxxP-xxx	MV-P1A-ADAB-DM-DxxP-xxx	MV-P1A-AGAB-DM-DxxP-xxx

#### SOLENOID OPERATOR ▶

### DM-D **XX** P-**XXX**\*

<b>XX</b> Voltage	<b>X</b> Manual operator	<b>XX</b> Electrical connection
<b>JA</b> 110/50, 120/60 (2.9W)	<b>1</b> Non-locking recessed	<b>DM</b> Plug-in
<b>JB</b> 220/50, 240/60 (2.9W)	<b>2</b> Locking recessed	<b>DN</b> Plug-in with diode
<b>JC</b> 24/50, 24/60 (2.9W)		<b>DP</b> Plug-in with M.O.V.
<b>FB</b> 24 VDC (1.8W)		<b>DG</b> Plug-in with ground
<b>DA</b> 24 VDC (5.4W)		
<b>DF</b> 24 VDC (12.7W)		

\* Other options available, see page 309.  
 Note: - ISO series, valve and base are ordered separately, see page 233 for base codes.  
 - Ground wire required for 30 volts or higher.

### OPTIONS

Valve function :

MV-P1A-A**XXX**-XX-DxxP-xxx

- J** for single operator universal spool (ext. pilot only)
- K** for double operator universal spool (ext. pilot only)

Pilot style :

MV-P1A-A**XXX**-**DM**-DxxP-xxx

- DM** Pilot exhaust muffled
- DP** Pilot exhaust piped (#10-32)

Spool return :

MV-P1A-A**XXA**-XX-DxxP-xxx

- A** Standard return
- B** Memory spring return
- D** Standard return with light
- E** Memory spring return with light

33  
34  
36  
32  
37  
38  
52  
67  
69  
44  
46  
42  
47  
48P  
48  
400  
92  
93  
ISO 01  
ISO 02  
ISO 1  
ISO 2  
ISO 3

**TECHNICAL DATA**

<b>Fluid :</b>	Compressed air, vacuum, inert gases
<b>Pressure range :</b>	Internal pilot: 20 to 120 PSI External pilot : vacuum to 120 PSI
<b>Pilot pressure :</b>	Single/double operator : 20 to 120 PSI, 3 positions : 30 to 120 PSI
<b>Lubrication :</b>	Not required, if used select a medium aniline point lubricant (between 180°F and 210°F)
<b>Filtration :</b>	40 μ
<b>Temperature range :</b>	0°F to 120°F (-18°C to +50°C)
<b>Flow :</b>	3/8": (1.8 C <sub>v</sub> ) – 1/4": (1.6 C <sub>v</sub> )
<b>Coil :</b>	Class A continuous duty, #22 AWG x 12 base leads
<b>Voltage range :</b>	-15% to +10% of nominal voltage
<b>Protection :</b>	Consult factory
<b>Power :</b>	~ Inrush 7.6 VA    Holding: 4.8 VA = 1 to 12.7 W
<b>Response times : (with 5,4 W coil)</b>	Energize : 10 ms De-energize : 9 ms

- Options :
- Sandwich flow controls: FCP1A-AA (screwdriver slot adjustment)  
FCP1A-AB (locking knob adjustment)
  - Sandwich regulator, see „Regulators“ section

- Spare parts :
- Pilot valve: DMB-DxxP-xxx • Valve to base pressure seal: 16661

**DIMENSIONS**

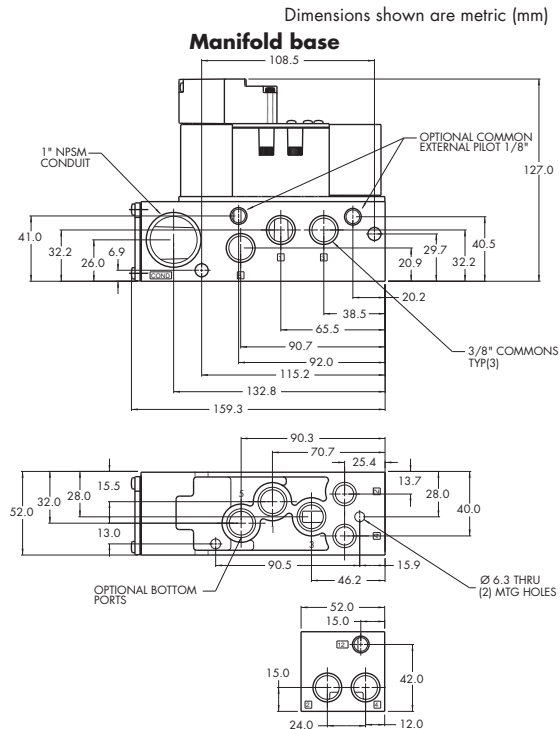
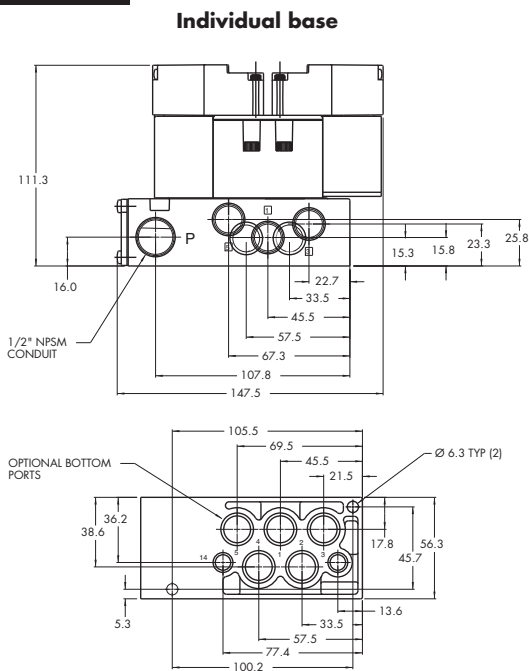

Individual mounting		Series
Valve only - No base non "plug-in" Conform to ISO 5599/1	Valve only - No base "plug-in" Conform to ISO 5599/2	
		<b>33</b>
		<b>34</b>
Manifold mounting		
Valve only - No base non "plug-in" Conform to ISO 5599/1	Valve only - No base "plug-in" Conform to ISO 5599/2	
		<b>36</b>
		<b>32</b>
		<b>37</b>
		<b>38</b>
		<b>52</b>
		<b>67</b>
		<b>69</b>
		<b>44</b>
		<b>46</b>
		<b>42</b>
		<b>47</b>
		<b>48P</b>
		<b>48</b>
		<b>400</b>
		<b>92</b>
		<b>93</b>
		<b>ISO 01</b>
		<b>ISO 02</b>
		<b>ISO 1</b>
		<b>ISO 2</b>
		<b>ISO 3</b>

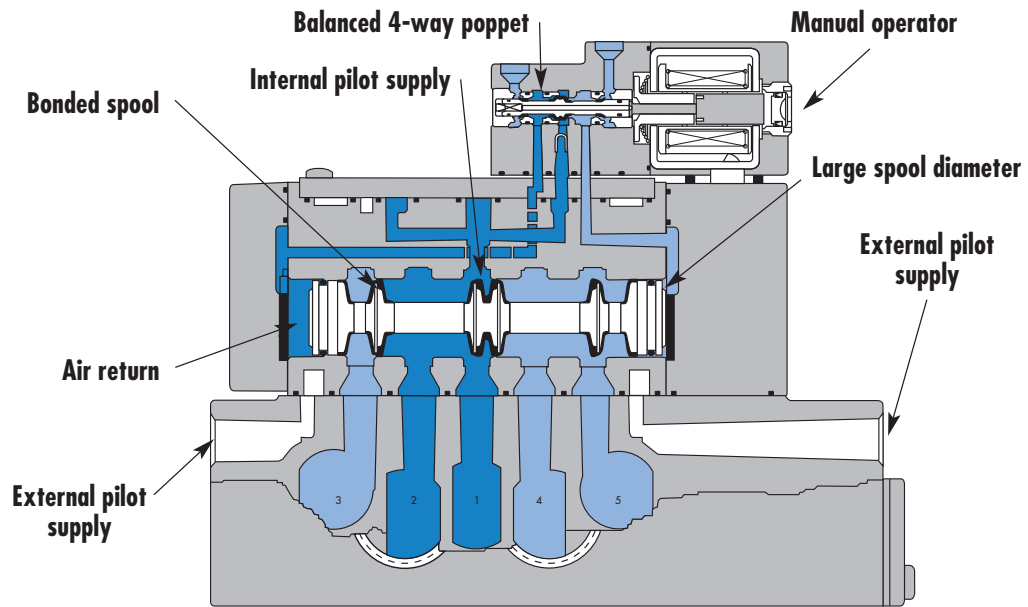

**SERIES FEATURES**

- Plug-in (5599/2) and non plug-in (5599/1) models.
- 2-position, single or double operator. (Solenoid or Remote Air)
- 3-position, double solenoid, open center, closed center, and pressure center.
- Extended or recessed manual operators.
- Single pressure and dual pressure.
- Individual base or add-a-unit manifold base.
- Plug-in, sandwich, single and dual pressure regulators for both individual and manifold valves.

Function	Port size	Flow (Max)	Individual/Manifold mounting	Series
<b>5/2, 5/3</b>	<b>3/8" - 1/2"</b>	<b>3.0 C<sub>v</sub></b>	Valve only - No base non "plug-in" Conform to ISO 5599/1	

### OPERATIONAL BENEFITS

1. Unique patented Macsolenoid® for fastest possible response times and virtually burn-out proof AC solenoid operation.
2. Balanced poppet 4-way pilot valve provides maximum shifting forces, precise repeatability and consistent operation.
3. MAC spool and bore combination wipes away contamination, eliminates sticking and allows for use on non-lube service.
4. Large spool area for maximum shifting forces even at minimum operating pressure.
5. Very high flow in a compact package.
6. Plug-in design of valves, bases and regulators for modular assembly and ease of maintenance.
7. Internal or external pilot operation. Manifolds supplied with common external pilot.
8. Air only return. Optional memory spring is also available.
9. Optional low wattage DC solenoid down to 1.0 watt.



### HOW TO ORDER

#### SINGLE PRESSURE MODELS

Pilot air	5/2 Single operator	5/2 Double operator	5/3 Closed center	5/3 Open center
Internal	MV-B2A-AAAA-DM-Dxxx-xxx	MV-B2A-ABAA-DM-Dxxx-xxx	MV-B2A-AEAA-DM-Dxxx-xxx	MV-B2A-AFAA-DM-Dxxx-xxx
External "12" end	MV-B2A-AAAB-DM-Dxxx-xxx	MV-B2A-ABAB-DM-Dxxx-xxx	MV-B2A-AEAB-DM-Dxxx-xxx	MV-B2A-AFAB-DM-Dxxx-xxx

#### DUAL PRESSURE MODELS

Pilot air	5/2 Single operator	5/2 Double operator	5/3 Pressure center
Internal pilot From port #3	MV-B2A-ACAD-DM-Dxxx-xxx	MV-B2A-ADAD-DM-Dxxx-xxx	MV-B2A-AGAD-DM-Dxxx-xxx
Internal pilot From port #5	MV-B2A-ACAE-DM-Dxxx-xxx	MV-B2A-ADAE-DM-Dxxx-xxx	MV-B2A-AGAE-DM-Dxxx-xxx
External pilot From "12" end	MV-B2A-ACAB-DM-Dxxx-xxx	MV-B2A-ADAB-DM-Dxxx-xxx	MV-B2A-AGAB-DM-Dxxx-xxx

#### SOLENOID OPERATOR >

### DM-D XXX-XXX\*

XX Voltage	X Lead wire length	X Manual operator	XX Electrical connection
<b>JA</b> 110/50, 120/60	<b>A</b> 18" (Flying leads)	<b>1</b> Non-locking recessed	<b>KA</b> Square connector
<b>JB</b> 220/50, 240/60	<b>B</b> 24" (Flying leads)	<b>2</b> Locking recessed	<b>KD</b> Square connector with light
<b>JC</b> 24/50, 24/60	<b>J</b> Connector		<b>JB</b> Rectangular connector
<b>FB</b> 24 VDC (1.8W)			<b>JD</b> Rectangular connector with light
<b>DA</b> 24 VDC (5.4W)			<b>BA</b> Flying leads
<b>DF</b> 24 VDC (12.7W)			

\* Other options available, see page 309.

Note: ISO series, valve and base are ordered separately, see page 235 for base code.

### OPTIONS

Valve function :

MV-B2A-**A**XXX-**XX**-Dxxx-xxx

- J** for single operator universal spool (ext. pilot only)
- K** for double operator universal spool (ext. pilot only)

Pilot style :

MV-B2A-XXX-**DM**-Dxxx-xxx

- DM** Pilot exhaust muffled
- DP** Pilot exhaust piped (#10-32)

Spool return :

MV-B2A-AX**A**X-**XX**-Dxxx-xxx

- A** Standard return
- B** Memory spring return

33  
34  
36  
32  
37  
38  
52  
67  
69  
44  
46  
42  
47  
48P  
48  
400  
92  
93  
ISO 01  
ISO 02  
ISO 1  
ISO 2  
ISO 3

**TECHNICAL DATA**

<b>Fluid :</b>	Compressed air, vacuum, inert gases
<b>Pressure range :</b>	Internal pilot: 20 to 120 PSI External pilot : vacuum to 120 PSI
<b>Pilot pressure :</b>	Single/double operator : 20 to 120 PSI, 3 positions : 30 to 120 PSI
<b>Lubrication :</b>	Not required, if used select a medium aniline point lubricant (between 180°F and 210°F)
<b>Filtration :</b>	40 µ
<b>Temperature range :</b>	0°F to 120°F (-18°C to +50°C)
<b>Flow :</b>	3/8": (2.8 C <sub>v</sub> ) - 1/2": (3.0 C <sub>v</sub> )
<b>Coil :</b>	Class A continuous duty, #22 AWG x 18 leads
<b>Voltage range :</b>	-15% to +10% of nominal voltage
<b>Protection :</b>	Consult factory
<b>Power :</b>	~ Inrush 7.6 VA    Holding: 4.8 VA = 12.7 to 1.0 W
<b>Response times :</b>	24 VDC 5.4w    Energize : 10 ms    De-energize : 9.6 ms 120/60    Energize : 6-15 ms    De-energize : 10-17 ms

- Options :
- Sandwich flow controls: FCP2A-BA (screwdriver slot adjustment)  
FCP2A-BB (locking knob adjustment)
  - Sandwich regulator, see „Regulators’ section

- Spare parts :
- Pilot valve: DMB-Dxxx-xxx • Valve to base pressure seal: 16576
  - Valve mounting screws (x4): 35413

**DIMENSIONS**

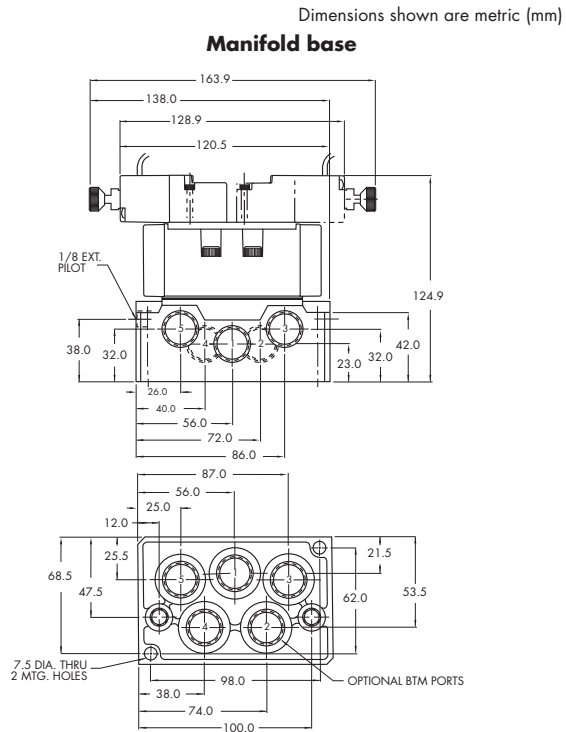
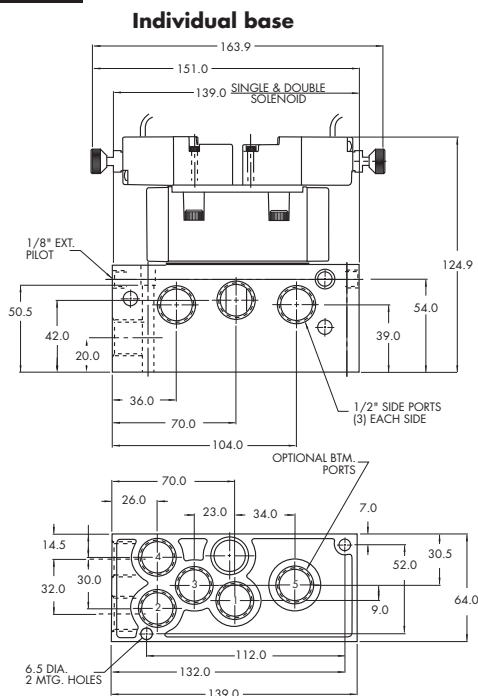

Function	Port size	Flow (Max)	Individual/Manifold mounting	Series
<b>5/2, 5/3</b>	<b>3/8" - 1/2"</b>	<b>3.0 C<sub>v</sub></b>	Valve only - No base "plug-in" Conform to ISO 5599/2	

### OPERATIONAL BENEFITS

1. Unique patented Macsolenoid® for fastest possible response times and virtually burn-out proof AC solenoid operation.
2. Balanced poppet 4-way pilot valve provides maximum shifting forces, precise repeatability and consistent operation.
3. MAC spool and bore combination wipes away contamination, eliminates sticking and allows for use on non-lube service.
4. Large spool area for maximum shifting forces even at minimum operating pressure.
5. Very high flow in a compact package.
6. Plug-in design of valves, bases and regulators for modular assembly and ease of maintenance.
7. Internal or external pilot operation. Manifolds supplied with common external pilot.
8. Air only return. Optional memory spring is also available.
9. Optional low wattage DC solenoid down to 1.0 watt.



### HOW TO ORDER

#### SINGLE PRESSURE MODELS

Pilot air	5/2 Single operator	5/2 Double operator	5/3 Closed center	5/3 Open center
Internal	MV-P2A-AAAA-DM-DxxP-xxx	MV-P2A-ABAA-DM-DxxP-xxx	MV-P2A-AEAA-DM-DxxP-xxx	MV-P2A-AFAA-DM-DxxP-xxx
External "12" end	MV-P2A-AAAB-DM-DxxP-xxx	MV-P2A-ABAB-DM-DxxP-xxx	MV-P2A-AEAB-DM-DxxP-xxx	MV-P2A-AFAB-DM-DxxP-xxx

#### DUAL PRESSURE MODELS

Pilot air	5/2 Single operator	5/2 Double operator	5/3 Pressure center
Internal pilot From port #3	MV-P2A-ACAD-DM-DxxP-xxx	MV-P2A-ADAD-DM-DxxP-xxx	MV-P2A-AGAD-DM-DxxP-xxx
Internal pilot From port #5	MV-P2A-ACAE-DM-DxxP-xxx	MV-P2A-ADAE-DM-DxxP-xxx	MV-P2A-AGAE-DM-DxxP-xxx
External pilot From "12" end	MV-P2A-ACAB-DM-DxxP-xxx	MV-P2A-ADAB-DM-DxxP-xxx	MV-P2A-AGAB-DM-DxxP-xxx

#### SOLENOID OPERATOR ▶

### DM-D **XX** P-**XXX**\*

<b>XX</b> Voltage	<b>X</b> Manual operator	<b>XX</b> Electrical connection
<b>JA</b> 110/50, 120/60	<b>1</b> Non-locking recessed	<b>DM</b> Plug-in
<b>JB</b> 220/50, 240/60	<b>2</b> Locking recessed	<b>DN</b> Plug-in with diode
<b>JC</b> 24/50, 24/60		<b>DP</b> Plug-in with M.O.V.
<b>FB</b> 24 VDC (1.8W)		<b>DG</b> Plug-in with ground
<b>DA</b> 24 VDC (5.4W)		
<b>DF</b> 24 VDC (12.7W)		

\* Other options available, see page 309.

Note: - ISO series, valve and base are ordered separately, see page 237 for base codes.  
- Ground wire required for 30 volts or higher.

### OPTIONS

Valve function :

MV-P2A-**A**XXX-XX-DxxP-xxx

- J** for single operator universal spool (ext. pilot only)
- K** for double operator universal spool (ext. pilot only)

Pilot style :

MV-P2A-**AXXX-DM**-DxxP-xxx

- DM** Pilot exhaust muffled
- DP** Pilot exhaust piped (#10-32)

Spool return :

MV-P2A-**AXA**-XX-DxxP-xxx

- A** Standard return
- B** Memory spring return
- D** Standard return with light
- E** Memory spring return with light

33  
34  
36  
32  
37  
38  
52  
67  
69  
44  
46  
42  
47  
48P  
48  
400  
92  
93  
ISO 01  
ISO 02  
ISO 1  
ISO 2  
ISO 3

**TECHNICAL DATA**

<b>Fluid :</b>	Compressed air, vacuum, inert gases
<b>Pressure range :</b>	Internal pilot: 20 to 120 PSI External pilot : vacuum to 120 PSI
<b>Pilot pressure :</b>	Single/double operator : 20 to 120 PSI, 3 positions : 30 to 120 PSI
<b>Lubrication :</b>	Not required, if used select a medium aniline point lubricant (between 180°F and 210°F)
<b>Filtration :</b>	40 µ
<b>Temperature range :</b>	0°F to 120°F (-18°C to +50°C)
<b>Flow :</b>	3/8": (2.8 C <sub>v</sub> ) - 1/2": (3.0 C <sub>v</sub> )
<b>Coil :</b>	Class A continuous duty, #18 AWG x 12 base leads
<b>Voltage range :</b>	-15% to +10% of nominal voltage
<b>Protection :</b>	Consult factory
<b>Power :</b>	~ Inrush 14.8 VA    Holding: 10.9 VA = 12.7 to 1.0 W
<b>Response times :</b>	24 VDC 5.4w    Energize : 10 ms    De-energize : 9.6 ms 120/60    Energize : 6-15 ms    De-energize : 10-17 ms

- Options :
- Sandwich flow controls: FCP2A-AA (screwdriver slot adjustment)  
FCP2A-AB (locking knob adjustment)
  - Sandwich regulator, see „Regulators‘ section

- Spare parts :
- Pilot valve: DMB-DxxP-xxx • Valve to base pressure seal: 16576
  - Valve mounting screws (x4): 35413

**DIMENSIONS**

**Individual base**

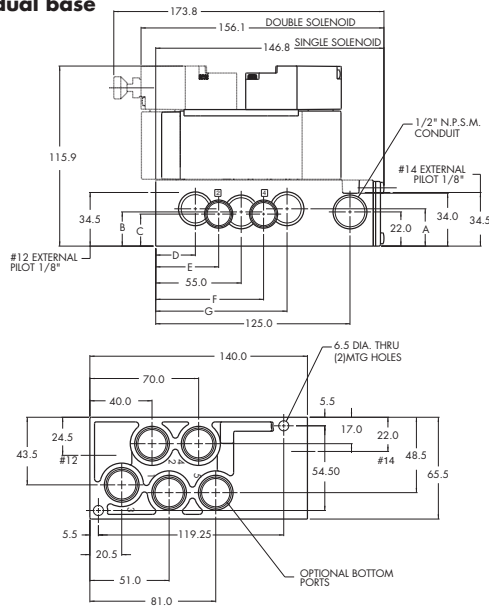

DIM.	A	B	C	D	E	F	G
3/8"	25.2	22.7	20.6	26.7	40.5	69.4	83.3
1/2"	24.0	21.0	19.0	25.5	40.0	70.0	84.5

**Manifold base**

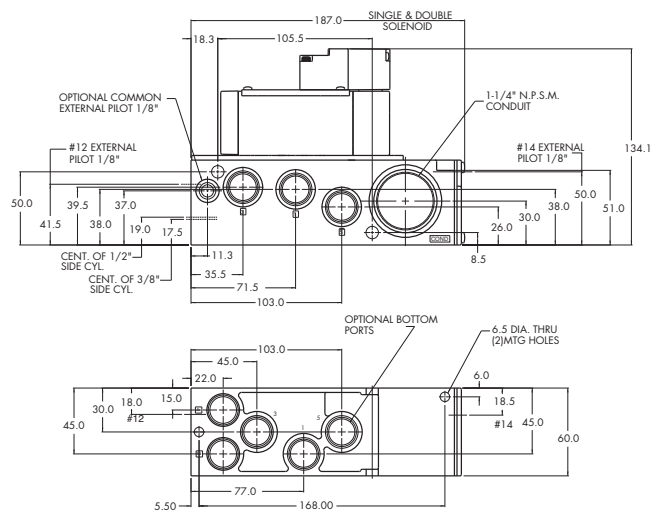



Individual mounting		Series
Valve only - No base non "plug-in" Conform to ISO 5599/1	Valve only - No base "plug-in" Conform to ISO 5599/2	33
Manifold mounting		34
Valve only - No base non "plug-in" Conform to ISO 5599/1	Valve only - No base "plug-in" Conform to ISO 5599/2	36
		32
		37
		38
		52
		67
		69
		44
		46
		42
		47
		48P
		48
		400
		92
		93
		ISO 01
		ISO 02
		ISO 1
		ISO 2
		<b>ISO 3</b>

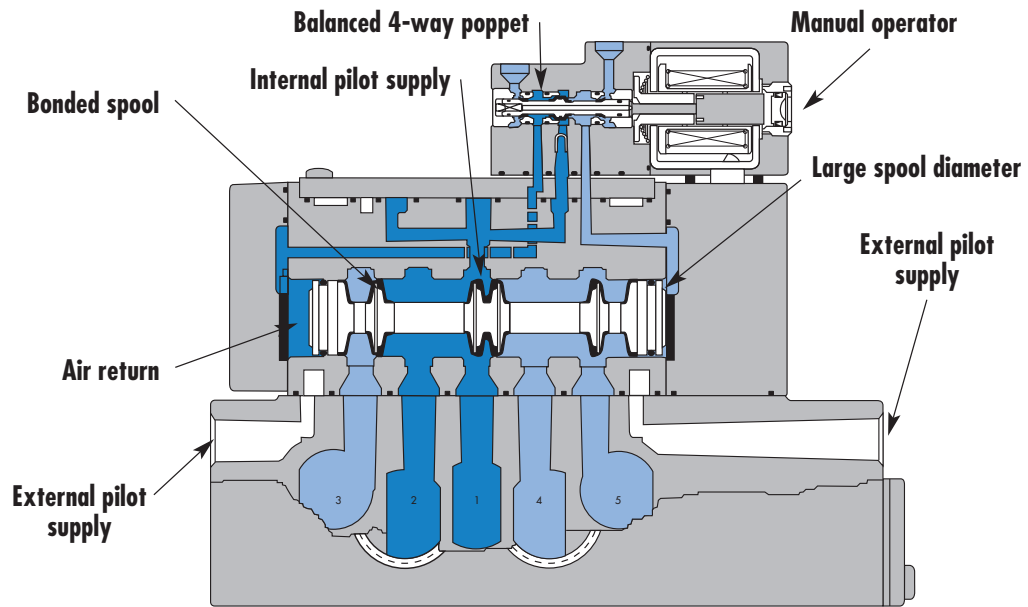

**SERIES FEATURES**

- Plug-in (5599/2) and non plug-in (5599/1) models.
- 2-position, single or double operator. (Solenoid or Remote Air)
- 3-position, double solenoid, open center, closed center, and pressure center.
- Extended or recessed manual operators.
- Single pressure and dual pressure.
- Individual base or add-a-unit manifold base.
- Plug-in, sandwich, single and dual pressure regulators for both individual and manifold valves.

Function	Port size	Flow (Max)	Individual/Manifold mounting	Series
<b>5/2, 5/3</b>	<b>1/2" - 3/4"</b>	<b>6.1 C<sub>v</sub></b>	Valve only - No base "non plug-in" Conform to ISO 5599/1	

### OPERATIONAL BENEFITS

1. Unique patented Macsolenoid® for fastest possible response times and virtually burn-out proof AC solenoid operation.
2. Balanced poppet 4-way pilot valve provides maximum shifting forces, precise repeatability and consistent operation.
3. MAC spool and bore combination wipes away contamination, eliminates sticking and allows for use on non-lube service.
4. Large spool area for maximum shifting forces even at minimum operating pressure.
5. Very high flow in a compact package.
6. Plug-in design of valves, bases and regulators for modular assembly and ease of maintenance.
7. Internal or external pilot operation. Manifolds supplied with common external pilot.
8. Air only return. Optional memory spring is also available.
9. Optional low wattage DC solenoid down to 1.0 watt.



33  
34  
36  
32  
37  
38  
52  
67  
69  
44  
46  
42  
47  
48P  
48  
400  
92  
93  
ISO 01  
ISO 02  
ISO 1  
ISO 2  
ISO 3

### HOW TO ORDER

#### SINGLE PRESSURE MODELS

Pilot air	5/2 Single operator	5/2 Double operator	5/3 Closed center	5/3 Open center
Internal	MV-B3A-AAAA-DM-Dxxx-xxx	MV-B3A-ABAA-DM-Dxxx-xxx	MV-B3A-AEAA-DM-Dxxx-xxx	MV-B3A-AFAA-DM-Dxxx-xxx
External "12" end	MV-B3A-AAAB-DM-Dxxx-xxx	MV-B3A-ABAB-DM-Dxxx-xxx	MV-B3A-AEAB-DM-Dxxx-xxx	MV-B3A-AFAB-DM-Dxxx-xxx

#### DUAL PRESSURE MODELS

Pilot air	5/2 Single operator	5/2 Double operator	5/3 Pressure center
Internal pilot From port #3	MV-B3A-ACAD-DM-Dxxx-xxx	MV-B3A-ADAD-DM-Dxxx-xxx	MV-B3A-AGAD-DM-Dxxx-xxx
Internal pilot From port #5	MV-B3A-ACAE-DM-Dxxx-xxx	MV-B3A-ADAE-DM-Dxxx-xxx	MV-B3A-AGAE-DM-Dxxx-xxx
External pilot From "12" end	MV-B3A-ACAB-DM-Dxxx-xxx	MV-B3A-ADAB-DM-Dxxx-xxx	MV-B3A-AGAB-DM-Dxxx-xxx

#### SOLENOID OPERATOR ▶

### DM-D XXX-XXX\*

XX Voltage	X Lead wire length	X Manual operator	XX Electrical connection
<b>JA</b> 110/50, 120/60	<b>A</b> 18" (Flying leads)	<b>1</b> Non-locking recessed	<b>KA</b> Square connector
<b>JB</b> 220/50, 240/60	<b>B</b> 24" (Flying leads)	<b>2</b> Locking recessed	<b>KD</b> Square connector with light
<b>JC</b> 24/50, 24/60	<b>J</b> Connector		<b>JB</b> Rectangular connector
<b>FB</b> 24 VDC (1.8W)			<b>JD</b> Rectangular connector with light
<b>DA</b> 24 VDC (5.4W)			<b>BA</b> Flying leads
<b>DF</b> 24 VDC (12.7W)			

\* Other options available, see page 309.

Note: ISO series, valve and base are ordered separately, see page 239 for base code.

### OPTIONS

Valve function :

MV-B3A-**A**XXX-**XX**-Dxxx-xxx

- J** for single operator universal spool (ext. pilot only)
- K** for double operator universal spool (ext. pilot only)

Pilot style :

MV-B3A-AXXX-**DM**-Dxxx-xxx

- DM** Pilot exhaust muffled
- DP** Pilot exhaust piped (#10-32)

Spool return :

MV-B3A-AX**A**X-**XX**-Dxxx-xxx

- A** Standard return
- B** Memory spring return

**TECHNICAL DATA**

<b>Fluid :</b>	Compressed air, vacuum, inert gases
<b>Pressure range :</b>	Internal pilot: 20 to 120 PSI External pilot : vacuum to 120 PSI
<b>Pilot pressure :</b>	Single/double operator : 20 to 120 PSI, 3 positions : 30 to 120 PSI
<b>Lubrication :</b>	Not required, if used select a medium aniline point lubricant (between 180°F and 210°F)
<b>Filtration :</b>	40 µ
<b>Temperature range :</b>	0°F to 120°F (-18°C to +50°C)
<b>Flow :</b>	1/2": (5.4 C <sub>v</sub> ) – 3/4": (6.1 C <sub>v</sub> )
<b>Coil :</b>	Class A continuous duty, #22 AWG leads
<b>Voltage range :</b>	-1.5% to +10% of nominal voltage
<b>Protection :</b>	Consult factory
<b>Power :</b>	~ Inrush 7.6 VA    Holding: 4.8 VA = 12.7 to 1.0 W
<b>Response times : (5.4 W coil)</b>	Energize : 16.2 ms De-energize : 13.6 ms

Options :                    • Sandwich regulator, see „Regulators“ section

Spare parts :            • Pilot valve: DMB-Dxxx-xxx • Valve to base pressure seal: 16614  
                                  • Valve mounting screws (x4): 35451

**DIMENSIONS**

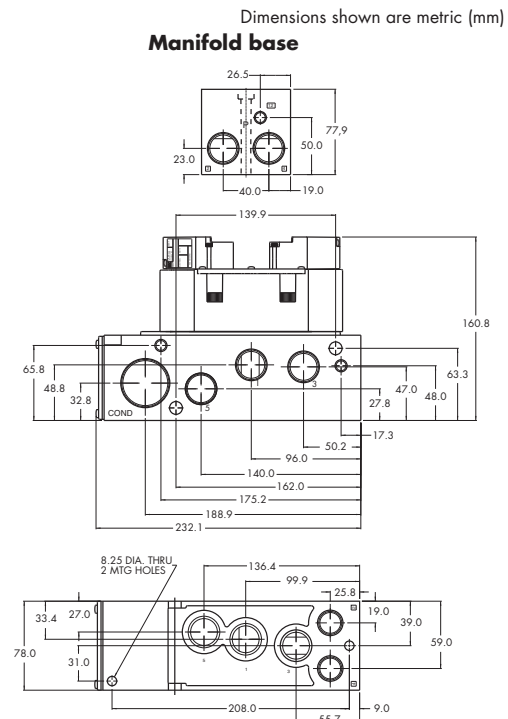
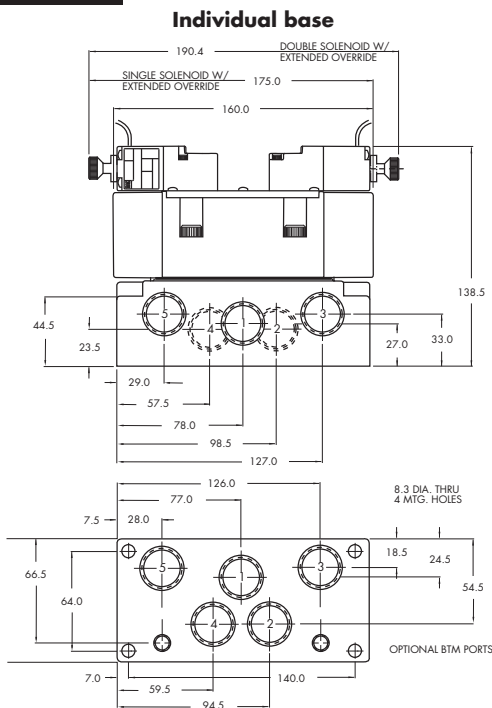

Function	Port size	Flow (Max)	Individual/Manifold mounting	Series
<b>5/2, 5/3</b>	<b>1/2" - 3/4"</b>	<b>6.1 C<sub>v</sub></b>	Valve only - No base "plug-in" Conform to ISO 5599/2	

### OPERATIONAL BENEFITS

1. Unique patented Macsolenoid® for fastest possible response times and virtually burn-out proof AC solenoid operation.
2. Balanced poppet 4-way pilot valve provides maximum shifting forces, precise repeatability and consistent operation.
3. MAC spool and bore combination wipes away contamination, eliminates sticking and allows for use on non-lube service.
4. Large spool area for maximum shifting forces even at minimum operating pressure.
5. Very high flow in a compact package.
6. Plug-in design of valves, bases and regulators for modular assembly and ease of maintenance.
7. Internal or external pilot operation. Manifolds supplied with common external pilot.
8. Air only return. Optional memory spring is also available.
9. Optional low wattage DC solenoid down to 1.0 watt.



### HOW TO ORDER

#### SINGLE PRESSURE MODELS

Pilot air	5/2 Single operator	5/2 Double operator	5/3 Closed center	5/3 Open center
Internal	MV-P3A-AAAA-DM-DxxP-xxx	MV-P3A-ABAA-DM-DxxP-xxx	MV-P3A-AEAA-DM-DxxP-xxx	MV-P3A-AFAA-DM-DxxP-xxx
External "12" end	MV-P3A-AAAB-DM-DxxP-xxx	MV-P3A-ABAB-DM-DxxP-xxx	MV-P3A-AEAB-DM-DxxP-xxx	MV-P3A-AFAB-DM-DxxP-xxx

#### DUAL PRESSURE MODELS

Pilot air	5/2 Single operator	5/2 Double operator	5/3 Pressure center
Internal pilot From port #3	MV-P3A-ACAD-DM-DxxP-xxx	MV-P3A-ADAD-DM-DxxP-xxx	MV-P3A-AGAD-DM-DxxP-xxx
Internal pilot From port #5	MV-P3A-ACAE-DM-DxxP-xxx	MV-P3A-ADAE-DM-DxxP-xxx	MV-P3A-AGAE-DM-DxxP-xxx
External pilot From "12" end	MV-P3A-ACAB-DM-DxxP-xxx	MV-P3A-ADAB-DM-DxxP-xxx	MV-P3A-AGAB-DM-DxxP-xxx

#### SOLENOID OPERATOR ▶

### DM-D **XX** P-**XXX**\*

<b>XX</b> Voltage	<b>X</b> Manual operator	<b>XX</b> Electrical connection
<b>JA</b> 110/50, 120/60 (2.9W)	<b>1</b> Non-locking recessed	<b>DM</b> Plug-in
<b>JB</b> 220/50, 240/60 (2.9W)	<b>2</b> Locking recessed	<b>DN</b> Plug-in with diode
<b>JC</b> 24/50, 24/60 (2.9W)		<b>DP</b> Plug-in with M.O.V.
<b>FB</b> 24 VDC (1.8W)		<b>DG</b> Plug-in with ground
<b>DA</b> 24 VDC (5.4W)		
<b>DF</b> 24 VDC (12.7W)		

\* Other options available, see page 309.  
 Note: - ISO series, valve and base are ordered separately, see page 241 for base codes.  
 - Ground wire required for 30 volts or higher.

### OPTIONS

Valve function :

MV-P3A-A**XXX**-XX-DxxP-xxx

- J** for single operator universal spool (ext. pilot only)
- K** for double operator universal spool (ext. pilot only)

Pilot style :

MV-P3A-A**XXX**-**DM**-DxxP-xxx

- DM** Pilot exhaust muffled
- DP** Pilot exhaust piped (#10-32)

Spool return :

MV-P3A-A**XX**A-XX-DxxP-xxx

- A** Standard return
- B** Memory spring return
- D** Standard return with light
- E** Memory spring return with light

33  
34  
36  
32  
37  
38  
52  
67  
69  
44  
46  
42  
47  
48P  
48  
400  
92  
93  
ISO 01  
ISO 02  
ISO 1  
ISO 2  
ISO 3

**TECHNICAL DATA**

<b>Fluid :</b>	Compressed air, vacuum, inert gases
<b>Pressure range :</b>	Internal pilot: 20 to 120 PSI External pilot : vacuum to 120 PSI
<b>Pilot pressure :</b>	Single/double operator : 20 to 120 PSI, 3 positions : 30 to 120 PSI
<b>Lubrication :</b>	Not required, if used select a medium aniline point lubricant (between 180°F and 210°F)
<b>Filtration :</b>	40 µ
<b>Temperature range :</b>	0°F to 120°F (-18°C to +50°C)
<b>Flow :</b>	1/2": (5.4 C <sub>v</sub> ) – 3/4": (6.1 C <sub>v</sub> )
<b>Coil :</b>	Class A continuous duty, #22 AWG leads
<b>Voltage range :</b>	-1.5% to +10% of nominal voltage
<b>Protection :</b>	Consult factory
<b>Power :</b>	~ Inrush 7.6 VA    Holding: 4.8 VA = 12.7 to 1.0 W
<b>Response times : (5.4 W coil)</b>	Energize : 16.2 ms De-energize : 13.6 ms

Options :                    • Sandwich regulator, see „Regulators“ section

Spare parts :             • Pilot valve: DMB-DxxP-xxx • Valve to base pressure seal: 16614  
                                     • Valve mounting screws (x4): 35451

**DIMENSIONS**

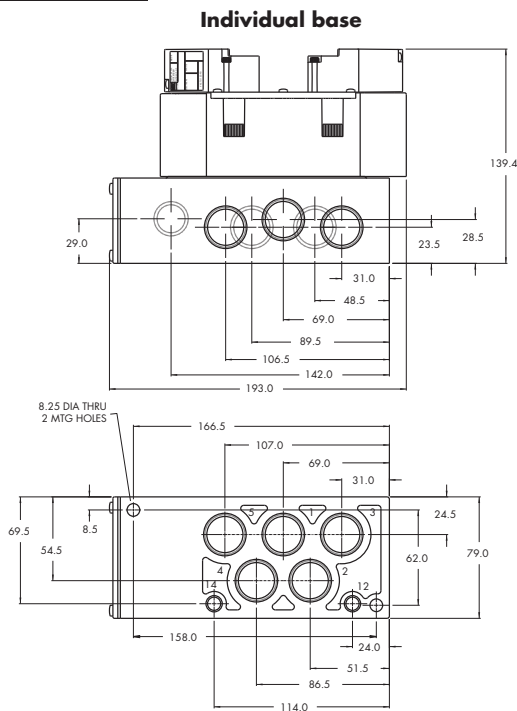

Dimensions shown are metric (mm)

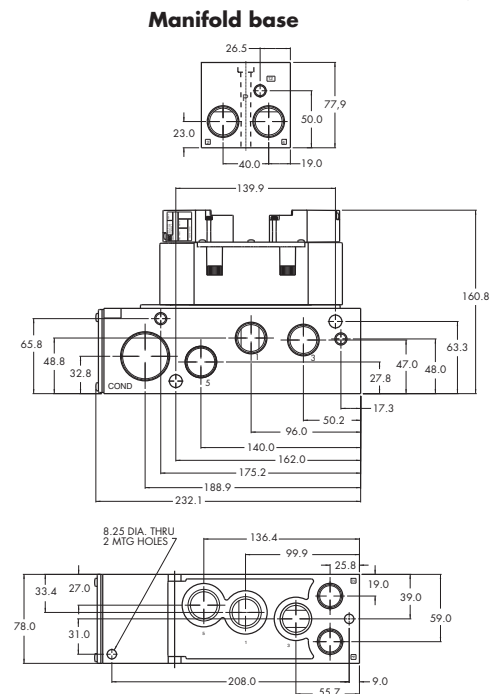



## Section 2

## Remote air valves

---





# R e m o t e a i r v a l v e s

Function	Port size	Flow [Max] Cv	Individual mounting			Manifold mounting	Series
			Inline	Sub-base non "plug-in"	Valve only - no base	Valve only - no base	
<b>5/2 - 5/3</b>	<b>1/8" - 1/4"</b>	<b>1.0</b>	P. 203	P. 205			<b>400</b>
<b>3/2</b>	<b>3/4" - 1"</b>	<b>20.0</b>	P. 209				<b>67</b>
<b>3/2 - 2/2</b>	<b>1 1/2" - 2" - 2 1/2"</b>	<b>60.0</b>	P. 213				<b>69</b>
<b>5/2 - 5/3</b>	<b>3/8" - 1/2"</b>	<b>3.1</b>			P. 217	P. 217	<b>ISO 2</b>
<b>5/2 - 5/3</b>	<b>1/2" - 3/4"</b>	<b>6.2</b>			P. 221	P. 221	<b>ISO 3</b>





# R e m o t e a i r v a l v e s

## Individual mounting

## Series

Inline	Sub-base non "plug-in"
--------	------------------------

**400**

**67**

**69**

**ISO 2**

**ISO 3**



# R e m o t e a i r v a l v e s

Function	Port size	Flow (Max)	Individual mounting	Series
<b>5/2 - 5/3</b>	<b>1/8" - 1/4"</b>	<b>1.0 C<sub>v</sub></b>	Inline	

### OPERATIONAL BENEFITS

1. Balanced spool, immune to variations of pressure, also provides high flow.
2. Bonded spool with minimum friction, shifting in a glass-like finished bore.
3. Wiping effect eliminates sticking.
4. Long service life.
5. Short stroke with high flow.



**400**  
**67**  
**69**  
**ISO 2**  
**ISO 3**

### HOW TO ORDER

#### SINGLE PRESSURE VALVES

Pilot air	5/2 Single operator	5/2 Double operator	5/3 Closed center	5/3 Open center	5/3 Pressure center
<b>1/8" NPTF</b>	411A-A0H-RA Mod 1493	421A-A0H-RA	451A-A0H-RA	461A-A0H-RA	471A-A0H-RA
<b>1/4" NPTF</b>	411A-B0H-RA Mod 1493	421A-B0H-RA	451A-B0H-RA	461A-B0H-RA	471A-B0H-RA

#### DUAL PRESSURE VALVES

Port size	5/2 Double operator
<b>1/8" NPTF</b>	441A-A0H-RA
<b>1/4" NPTF</b>	441A-B0H-RA

**TECHNICAL DATA**

<b>Fluid :</b>	Compressed air, vacuum, inert gases
<b>Pressure range :</b>	Single operator: vacuum to 100 PSI Double operator: vacuum to 150 PSI
<b>Air signal pressure :</b>	Single oper.: 40 to 150 PSI Double oper., 2 pos.: 20 to 150 PSI, 3 pos.: 35 to 150 PSI
<b>Lubrication :</b>	Not required, if used select a medium aniline point lubricant (between 180°F and 210°F)
<b>Filtration :</b>	40μ
<b>Temperature range :</b>	0°F to 120°F (-18°C to 50°C)
<b>Flow :</b>	1.0 C <sub>v</sub>
<b>Note :</b>	Air signal must be ≥ main valve pressure

Option : • BSPP threads

**DIMENSIONS**

Dimensions shown are metric (mm)

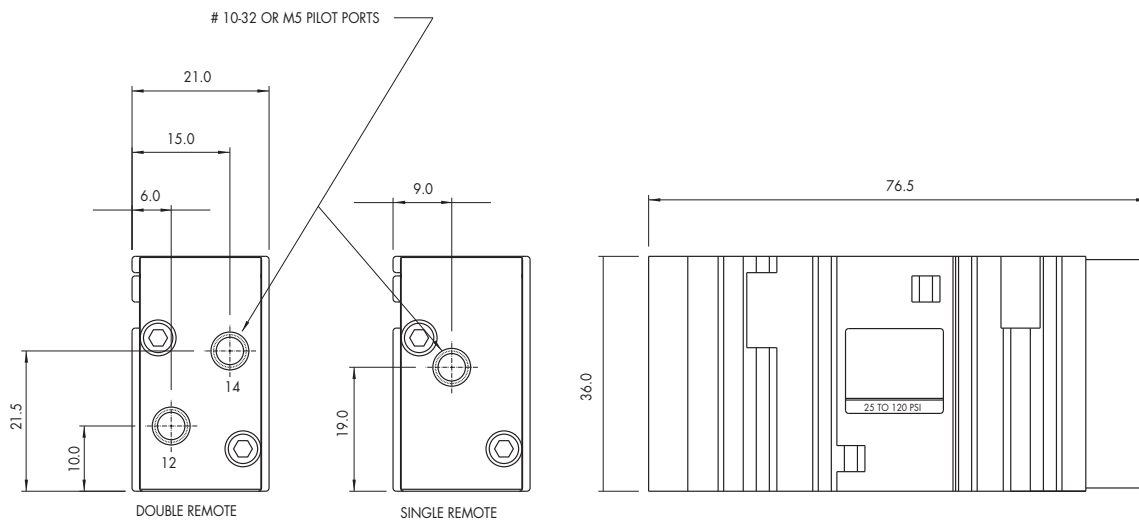



Function	Port size	Flow (Max)	Individual mounting	Series
<b>5/2 - 5/3</b>	<b>1/8" - 1/4"</b>	<b>1.0 C<sub>v</sub></b>	Sub-base non "plug-in"	

**OPERATIONAL BENEFITS**

1. Balanced spool, immune to variations of pressure, also provides high flow.
2. Bonded spool with minimum friction, shifting in a glass-like finished bore.
3. Wiping effect eliminates sticking.
4. Long service life.
5. Short stroke with high flow.



**400**  
**67**  
**69**  
**ISO 2**  
**ISO 3**

**HOW TO ORDER**

**SINGLE PRESSURE VALVES**

Port size	5/2 Single operator	5/2 Double operator	5/3 Closed center	5/3 Open center	5/3 Pressure center
<b>Valve less base</b>	413A-00H-RA	423A-00H-RA	453A-00H-RA	463A-00H-RA	473A-00H-RA
<b>1/8" NPTF</b>	413A-AAH-RA Mod 1493	423A-AAH-RA	453A-AAH-RA	463A-AAH-RA	473A-AAH-RA
<b>1/4" NPTF</b>	413A-BAH-RA Mod 1493	423A-BAH-RA	453A-BAH-RA	463A-BAH-RA	473A-BAH-RA

**DUAL PRESSURE VALVES**

Port size	5/2 Double operator
<b>1/8" NPTF</b>	443A-AAH-RA
<b>1/4" NPTF</b>	443A-BAH-RA

**OPTIONS**

423A-AAH-RA  
**B** for base with flow controls

**TECHNICAL DATA**

<b>Fluid :</b>	Compressed air, vacuum, inert gases
<b>Pressure range :</b>	Single operator: vacuum to 100 PSI Double operator: vacuum to 150 PSI
<b>Air signal pressure :</b>	Single oper.: 40 to 150 PSI Double oper., 2 pos.: 20 to 150 PSI, 3 pos.: 35 to 150 PSI
<b>Lubrication :</b>	Not required, if used select a medium aniline point lubricant (between 180°F and 210°F)
<b>Filtration :</b>	40µ
<b>Temperature range :</b>	0°F to 120°F (-18°C to 50°C)
<b>Flow :</b>	1.0 C <sub>v</sub>
<b>Note :</b>	Air signal must be ≥ main valve pressure

- Options :
- BSPP threads
- Spare parts :
- Valve to base pressure seal: 16525
  - Valve mounting screw (x2): 35043
  - Flow control assembly (x2): N-04001

**DIMENSIONS**

Dimensions shown are metric (mm)

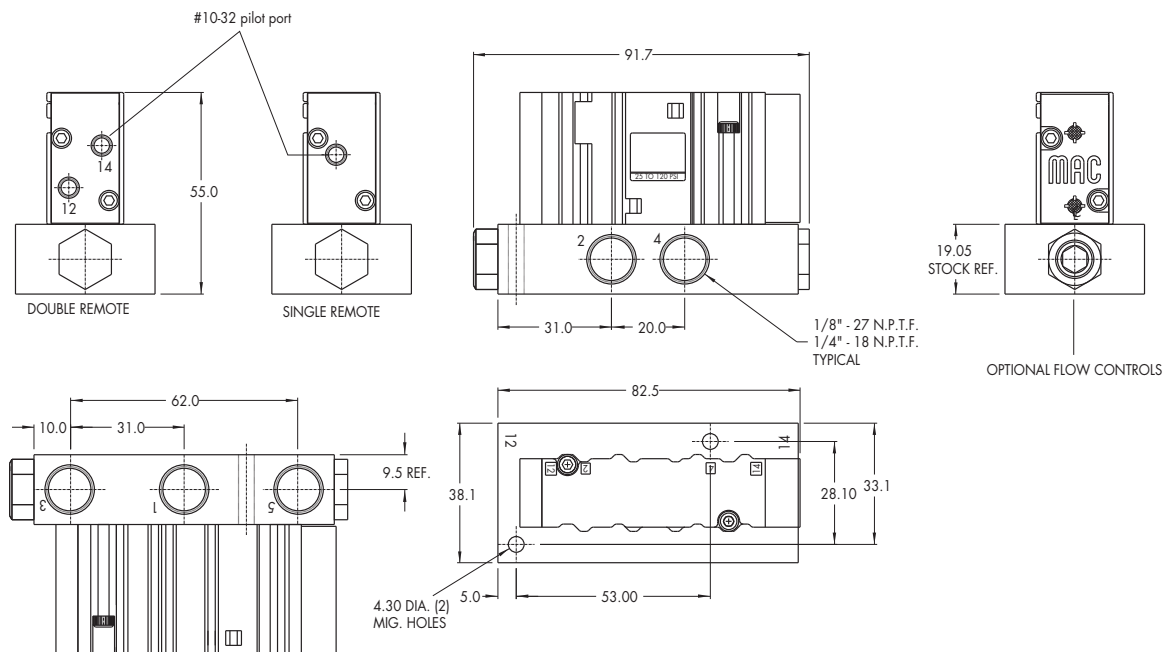



# R e m o t e   a i r   v a l v e s

Individual mounting

Series

Inline

400

**67**

69

ISO 2

ISO 3

Function	Port size	Flow (Max)	Individual mounting	Series
<b>3/2</b>	<b>3/4" - 1"</b>	<b>20.0 C<sub>v</sub></b>	Inline	

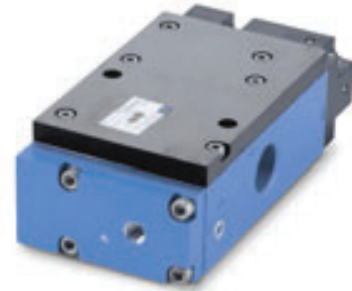

**OPERATIONAL BENEFITS**

1. Balanced spool, immune to variations of pressure.
2. Powerful return forces thanks to the combination of mechanical and air springs.
3. Bonded spool with minimum friction, shifting in a glass like finished bore.
4. Wiping effect eliminates sticking.
5. Long service life.

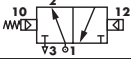
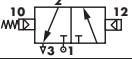

**400**  
**67**  
**69**  
**ISO 2**  
**ISO 3**

**HOW TO ORDER**

Port size	Pilot air	Single Operator		Double Operator	
		NO Valve	NC Valve	NO Valve	NC Valve
					
<b>3/4" NPTF</b>	Internal	67A-C3-ARA-RA	67A-A3-ARA-RA	67A-D4-ARA-RA	67A-B4-ARA-RA
<b>1" NPTF</b>		67A-C3-BRA-RA	67A-A3-BRA-RA	67A-D4-BRA-RA	67A-B4-BRA-RA
<b>3/4" NPTF</b>	External	67A-C3-ARB-RE	67A-A3-ARB-RE	-	-
<b>1" NPTF</b>		67A-C3-BRB-RE	67A-A3-BRB-RE	-	-

Note : Designation 'RE' required on remote air models with main valve pressures of vacuum to 20 PSI.

'RE' provides an external pilot and should have a pressure range of 20 - 75 PSI. Since the external pilot supplies the air spring, it must not exceed the remote air pilot pressure.

**TECHNICAL DATA**

<b>Fluid :</b>	Compressed air, vacuum, inert gases
<b>Pressure range :</b>	Vacuum to 150 PSI
<b>Air signal pressure :</b>	20 to 150 PSI (must be $\geq$ main valve pressure)
<b>Lubrication :</b>	Not required, if used select a medium aniline point lubricant (between 180°F to 210°F)
<b>Filtration :</b>	40 $\mu$
<b>Temperature range :</b>	0°F to 120°F (-18°C to 50°C)
<b>Flow :</b>	3/4" : (14.5 C <sub>v</sub> ) - 1" : (20.0 C <sub>v</sub> )

Options : • BSPP threads

**DIMENSIONS**

Dimensions shown are metric (mm)

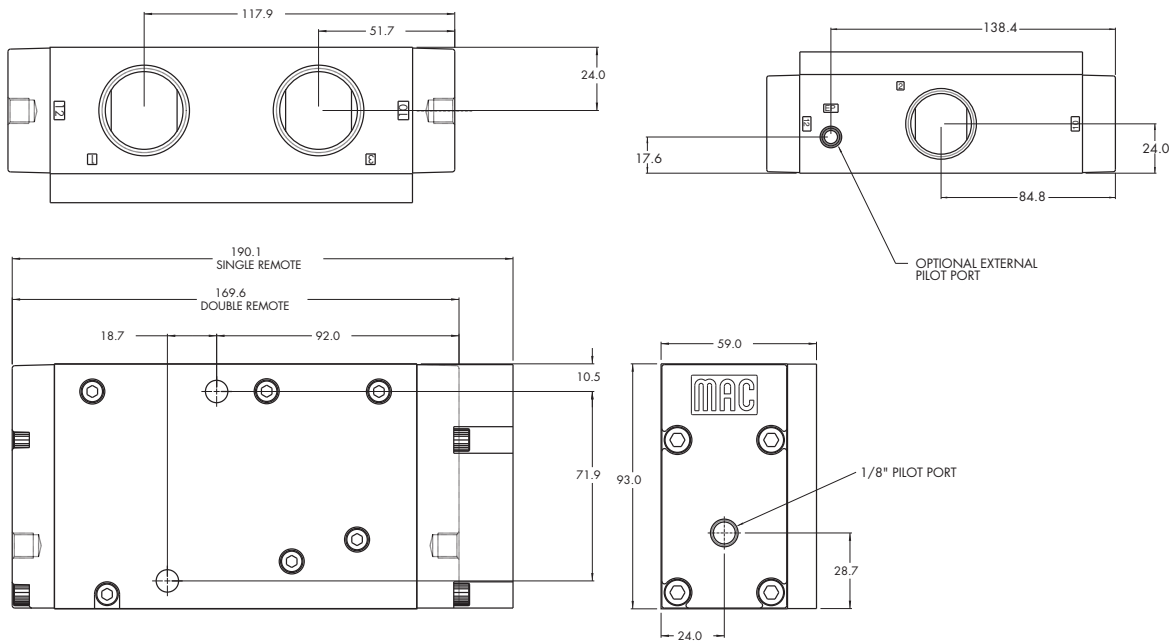





# R e m o t e a i r v a l v e s

Individual mounting

Series

Inline

400

67

**69**

ISO 2

ISO 3



# R e m o t e a i r v a l v e s

Function	Port size	Flow (Max)	Individual mounting	Series
<b>3/2 NO-NC, 2/2 NO-NC</b>	<b>1 1/2" - 2" - 2 1/2"</b>	<b>60.0 C<sub>v</sub></b>	Inline	

### OPERATIONAL BENEFITS

- Balanced spool, immune to variations of pressure
- Bonded spool with minimum friction, shifting in a glass like finished bore
- Wiping effect eliminates sticking and contamination
- Long service life

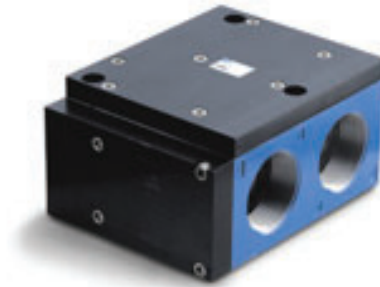

**400**  
**67**  
**69**  
**ISO 2**  
**ISO 3**

### HOW TO ORDER

#### SINGLE OPERATOR

Port size	Air Spring	Single Operator NO valve	Single Operator NC valve
<b>1 1/2"</b>	Internal	69A-C3-ARA-RA	69A-A3-ARA-RA
<b>2"</b>		69A-C3-BRA-RA	69A-A3-BRA-RA
<b>2 1/2"</b>		69A-C3-CRA-RA	69A-A3-CRA-RA
<b>1 1/2"</b>	External	69A-C3-ARB-RE	69A-A3-ARB-RE
<b>2"</b>		69A-C3-BRB-RE	69A-A3-BRB-RE
<b>2 1/2"</b>		69A-C3-CRB-RE	69A-A3-CRB-RE

#### DOUBLE OPERATOR

Port size	Double Operator NO valve	Double Operator NC valve
<b>1 1/2"</b>	69A-D4-ARB-RA	69A-B4-ARB-RA
<b>2"</b>	69A-D4-BRB-RA	69A-B4-BRB-RA
<b>2 1/2"</b>	69A-D4-CRB-RA	69A-B4-CRB-RA

**TECHNICAL DATA**

<b>Fluid :</b>	Compressed air, vacuum, inert gases
<b>Pressure range :</b>	Vacuum to 150 PSI
<b>Air signal pressure :</b>	20 to 150 PSI (must be $\geq$ main valve pressure)
<b>Lubrication :</b>	Not required, if used select a medium aniline point lubricant (between 180°F to 210°F)
<b>Filtration :</b>	40 $\mu$
<b>Temperature range :</b>	0°F to 120°F (-18°C to 50°C)
<b>Flow :</b>	Cv 60.0

**DIMENSIONS**

Dimensions shown are metric (mm)

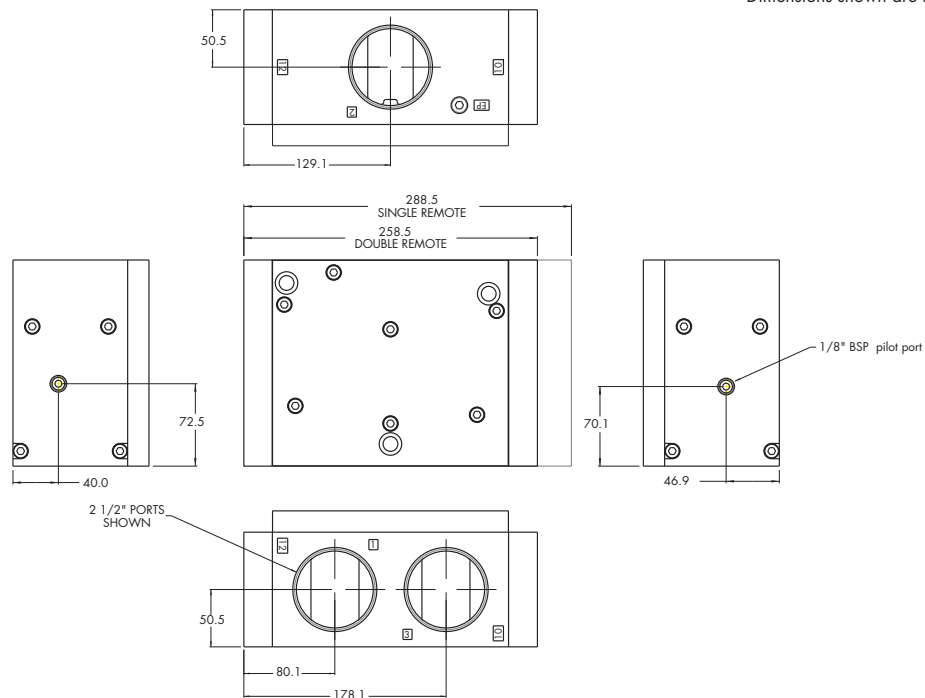



R e m o t e   a i r   v a l v e s

Individual mounting

Series

Valve only -  
no base

400

Manifold mounting

67

Valve only -  
no base

69

**ISO 2**

ISO 3

Function	Port size	Flow (Max)	Individual/Manifold mounting	Series
<b>5/2 - 5/3</b>	<b>3/8" - 1/2"</b>	<b>3.1 C<sub>v</sub></b>	Valve only - no base	

**OPERATIONAL BENEFITS**

1. Balanced spool, immune to variations of pressure.
2. Powerful return forces thanks to the combination of mechanical and air springs.
3. Bonded spool with minimum friction, shifting in a glass-like finished bore.
4. Wiping effect eliminates sticking.
5. Long service life.



**400**  
**67**  
**69**  
**ISO 2**  
**ISO 3**

**HOW TO ORDER**

**SINGLE PRESSURE MODELS**

Air spring	5/2 Single operator	5/2 Double operator	5/3 Closed center	5/3 Open center
Internal	MV-R2A-BACF	MV-R2A-BBAK	MV-R2A-BEAK	MV-R2A-BFAK
External	MV-R2A-BACG			

**DUAL PRESSURE MODELS**

Air spring	5/2 Single operator	5/2 Double operator	5/3 Open center	5/3 Pressure center
Internal port #3	MV-R2A-BCCH	MV-R2A-BDAK	MV-R2A-BHAK	MV-R2A-BGAK
Internal port #5	MV-R2A-BCCJ			
External	MV-R2A-BCCG			

Note: ISO series, valve and base are ordered separately, see page 235 for base code.

**TECHNICAL DATA**

<b>Fluid :</b>	Compressed air, vacuum, inert gases
<b>Pressure range :</b>	Vacuum to 150 PSI
<b>Air signal pressure :</b>	Single/double operator: 20 to 150 PSI 3 position: 30 to 150 PSI
<b>Lubrication :</b>	Not required, if used select a medium aniline point lubricant (between 180°F and 210°F)
<b>Filtration :</b>	40 μ
<b>Temperature range :</b>	0°F to 120°F (-18°C to 50°C)
<b>Flow :</b>	3/8" : (2.8 Cv) - 1/2" : (3.1 Cv)

Spare parts : • Valve to base pressure seal: 16576 • Valve mounting screws (x4): 35413

**DIMENSIONS**

Dimensions shown are metric (mm)

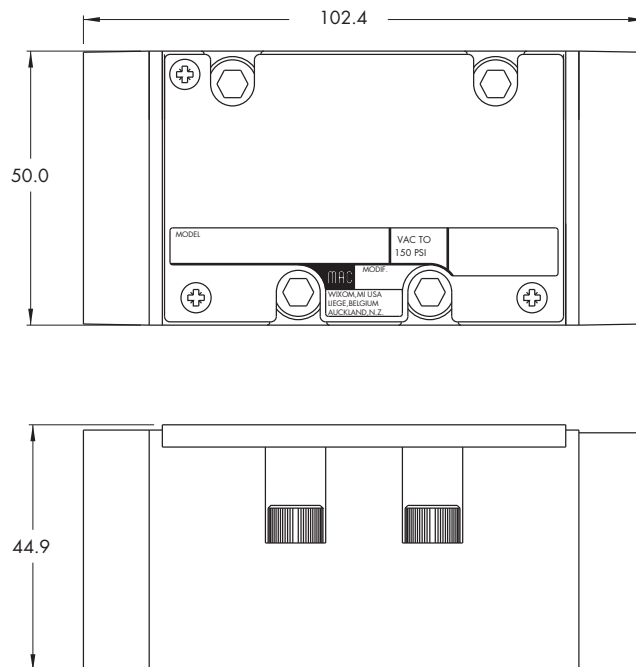



R e m o t e   a i r   v a l v e s

Individual mounting

Series

Valve only -  
no base

**400**

Manifold mounting

**67**

Valve only -  
no base

**69**

**ISO 2**

**ISO 3**

Function	Port size	Flow (Max)	Individual/Manifold mounting	Series
<b>5/2 - 5/3</b>	<b>1/2" - 3/4"</b>	<b>6.2 C<sub>v</sub></b>	Valve only - no base	

**OPERATIONAL BENEFITS**

- Balanced spool, immune to variations of pressure.
- Powerful return forces thanks to the combination of mechanical and air springs.
- Bonded spool with minimum friction, shifting in a glass-like finished bore.
- Wiping effect eliminates sticking.
- Long service life.



**400**  
**67**  
**69**  
**ISO 2**  
**ISO 3**

**HOW TO ORDER**

**SINGLE PRESSURE MODELS**

Air spring	5/2 Single operator	5/2 Double operator	5/3 Closed center	5/3 Open center
Internal	MV-R3A-BACF	MV-R3A-BBAK	MV-R3A-BEAK	MV-R3A-BFAK
External	MV-R3A-BACG			

**DUAL PRESSURE MODELS**

Air spring	5/2 Single operator	5/2 Double operator	5/3 Pressure center
Internal port #3	MV-R3A-BCCH		MV-R3A-BGAK
Internal port #5	MV-R3A-BCCJ	MV-R3A-BDAK	
External	MV-R3A-BCCG		

Note: ISO series, valve and base are ordered separately, see page 239 for base code.



**TECHNICAL DATA**

<b>Fluid :</b>	Compressed air, vacuum, inert gases
<b>Pressure range :</b>	Vacuum to 150 PSI
<b>Air signal pressure :</b>	Single/double operator: 20 to 150 PSI 3 position: 30 to 150 PSI
<b>Lubrication :</b>	Not required, if used select a medium aniline point lubricant (between 180°F and 210°F)
<b>Filtration :</b>	40 µ
<b>Temperature range :</b>	0°F to 120°F (-18°C to 50°C)
<b>Flow :</b>	1/2" : (5.4 C <sub>v</sub> ) - 3/4" : (6.2 C <sub>v</sub> )

Spare parts : • Valve to base pressure seal: 16614 • Valve mounting screws (x4): 35451

**DIMENSIONS**

Dimensions shown are metric (mm)

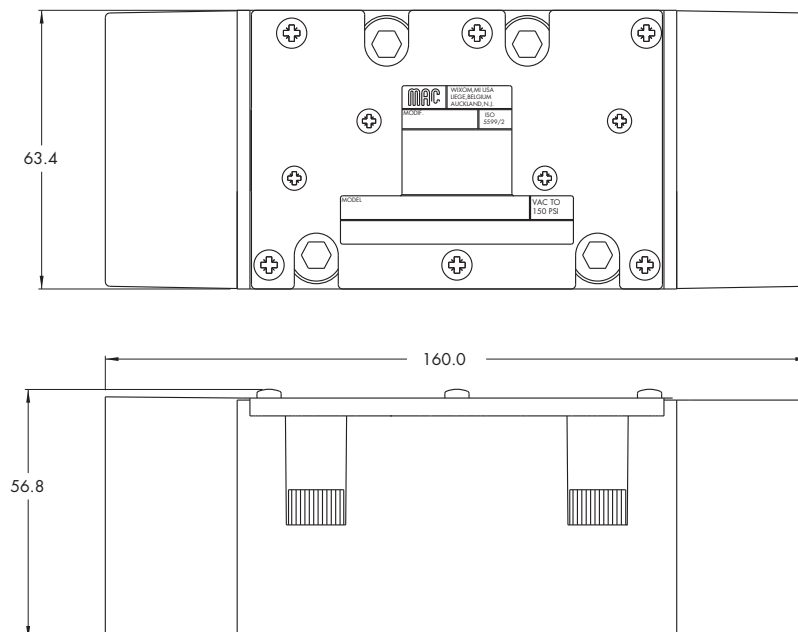



## Section 3

## Bases according to ISO standards

---



# Bases according to ISO STANDARDS

			Series
Non plug-in individual / manifold base	Non plug-in base / manifold	Plug-in base / manifold	
P. 227			<b>ISO 01</b>
P. 229			<b>ISO 02</b>
	P. 231	P. 233	<b>ISO 1</b>
	P. 235	P. 237	<b>ISO 2</b>
	P. 239	P. 241	<b>ISO 3</b>

**Non plug-in individual / manifold base**



**ISO 01**

**ISO 02**

**ISO 1**

**ISO 2**

**ISO 3**

**HOW TO ORDER**

INDIVIDUAL BASE

Port size	Pilot air	Side ports	Bottom 2 & 4 ports With all side ports
<b>1/4" NPTF</b>	Internal	MB-A01A-121	MB-A01A-122

MANIFOLD BASE

Port size	Pilot air	Side ports	Bottom 2 & 4 ports With side 1, 3 & 5 ports
<b>1/4" NPTF</b>	Internal	MM-A01A-121	MM-A01A-122

Notes:

- For manifold bases external pilot is common
- A base is ordered as internal pilot and can be changed into external pilot by removing pipe plugs from the external pilot ports (individual base).
- Manifold base: same base for internal and external pilot, different end plate kits.

End plate kit: Internal pilot M-00017-01-01  
External pilot M-00017-02-01

Inlet/exhaust isolator: 28413

**DIMENSIONS**

Dimensions shown are metric (mm)

Individual

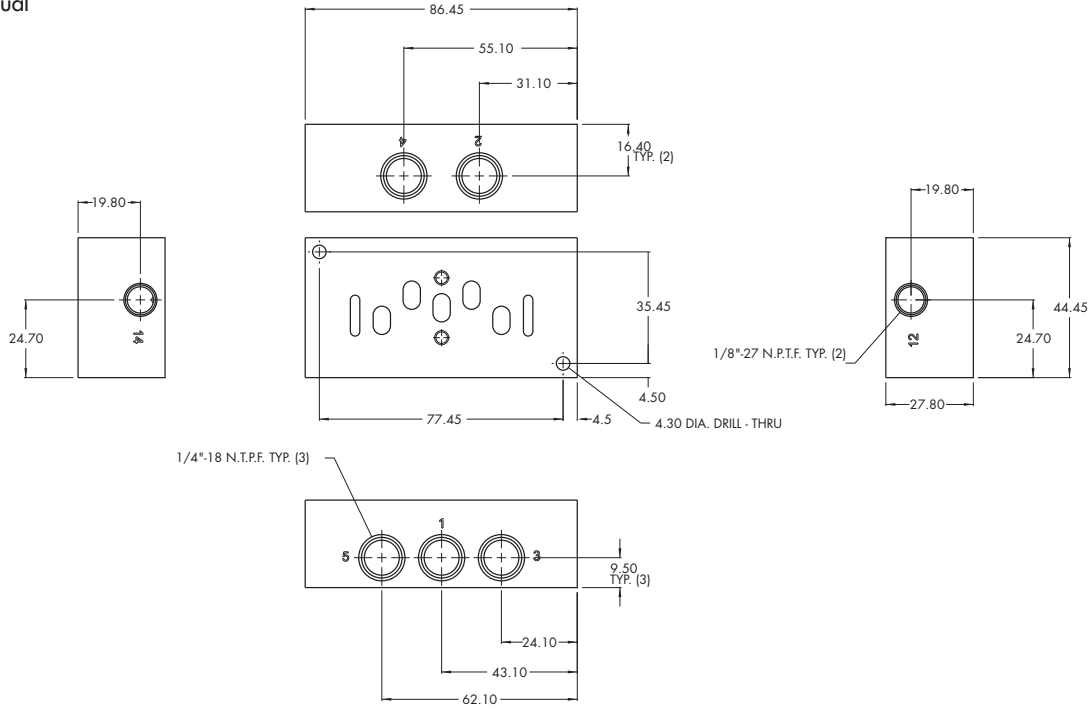

Manifold

LEFT SIDE

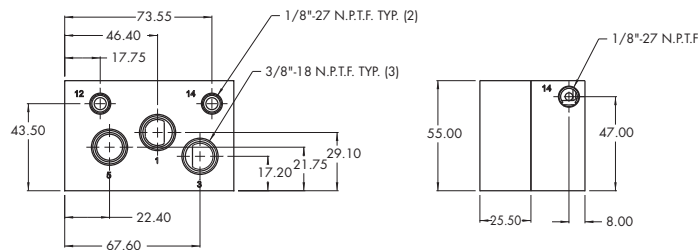

RIGHT SIDE

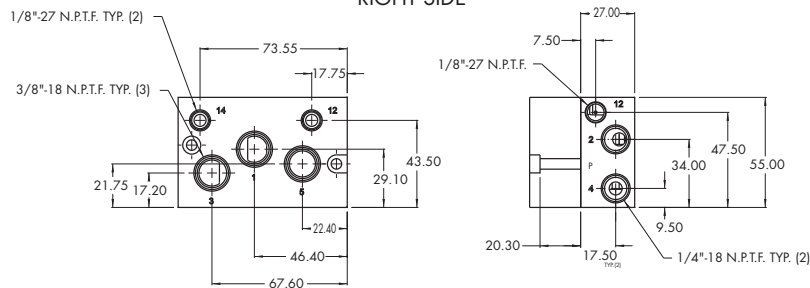

**Non plug-in individual / manifold base**



ISO 01  
**ISO 02**  
 ISO 1  
 ISO 2  
 ISO 3

**HOW TO ORDER**

INDIVIDUAL BASE

Port size	Pilot air	Side ports	Bottom 2 & 4 ports With all side ports
<b>1/8" NPTF</b>	Internal	MB-A02A-111	MB-A02A-112

MANIFOLD BASE

Port size	Pilot air	Side ports	Bottom 2 & 4 ports With side 1, 3 & 5 ports
<b>1/8" NPTF</b>	Internal	MM-A02A-111	MM-A02A-112

Notes:

- For manifold bases external pilot is common
- A base is ordered as internal pilot and can be changed into external pilot by removing pipe plugs from the external pilot ports (individual base).
- Manifold base: same base for internal and external pilot, different end plate kits.

End plate kit: Internal pilot M-00018-01-01  
 External pilot M-00018-02-01

Inlet/exhaust isolator: 28499

**DIMENSIONS**

Dimensions shown are metric (mm)

Individual

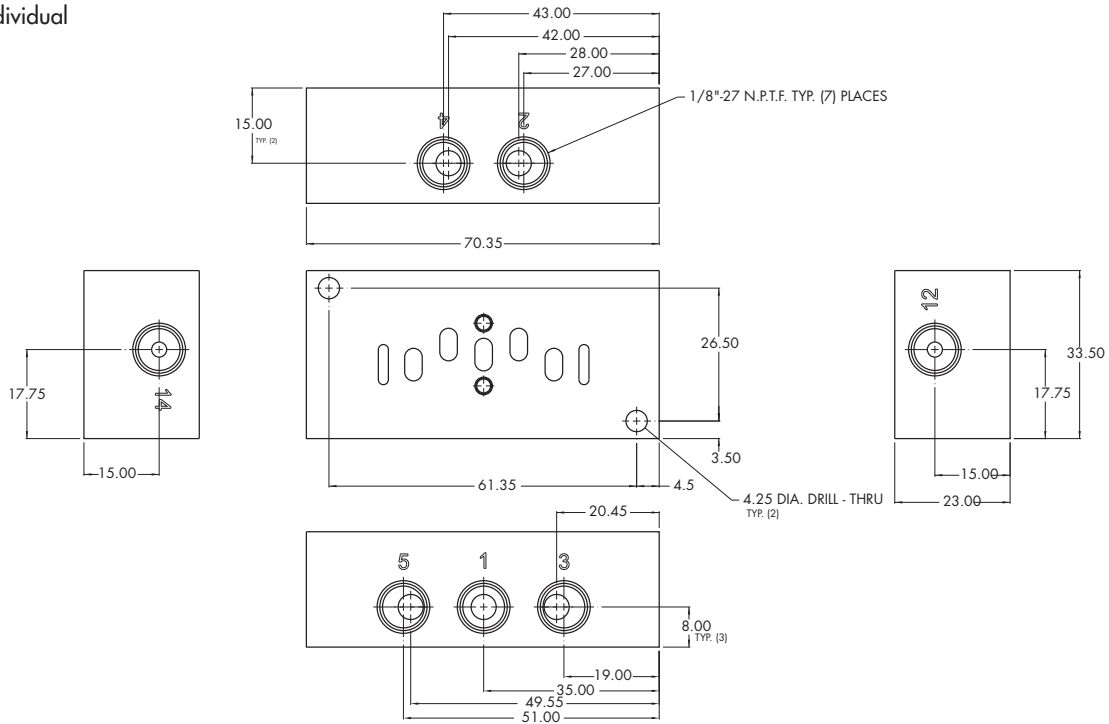

Manifold

LEFT SIDE

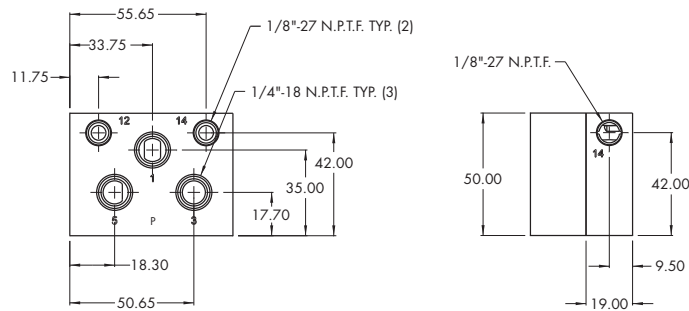

RIGHT SIDE

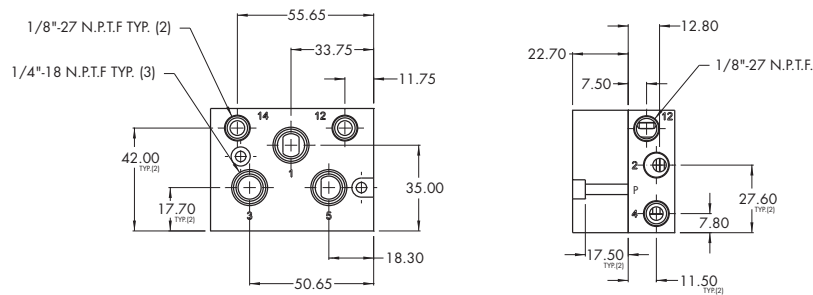

**Non plug-in base / manifold**



- ISO 01
- ISO 02
- ISO 1**
- ISO 2
- ISO 3

**HOW TO ORDER**

INDIVIDUAL BASE

Port size	Side ports	Side & bottom ports	Bottom cylinder ports 2 and 4.	Bottom inlet port 1
<b>1/4" NPTF</b>	MB-A1C-221	MB-A1C-223	MB-A1C-222	MB-A1C-224
<b>3/8" NPTF</b>	MB-A1C-231	MB-A1C-233	MB-A1C-232	MB-A1C-234

MANIFOLD BASE

Port size	Side ports	Side & bottom ports	Bottom cylinder ports 2 and 4.	Bottom inlet port 1
<b>1/4" NPTF</b>	MM-A1C-221	MM-A1C-223	MM-A1C-222	MM-A1C-224
<b>3/8" NPTF</b>	MM-A1C-231	MM-A1C-233	MM-A1C-232	MM-A1C-234

Manifold fastening kit : N-63002-01.  
 Valve blanking plate: MA1003.  
 Inlet/exhaust isolator plug: 32835.



**DIMENSIONS**

Dimensions shown are metric (mm)

**Individual**

**DIN 5599/1**

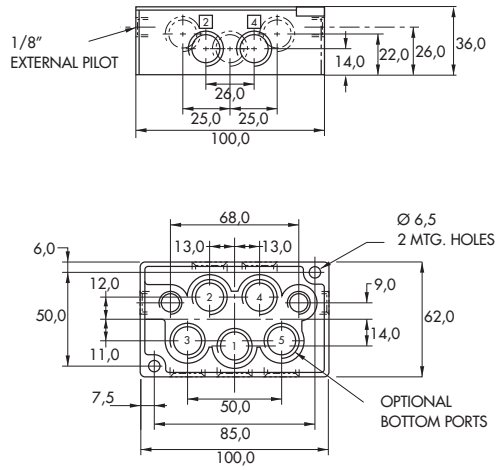

**Manifold**

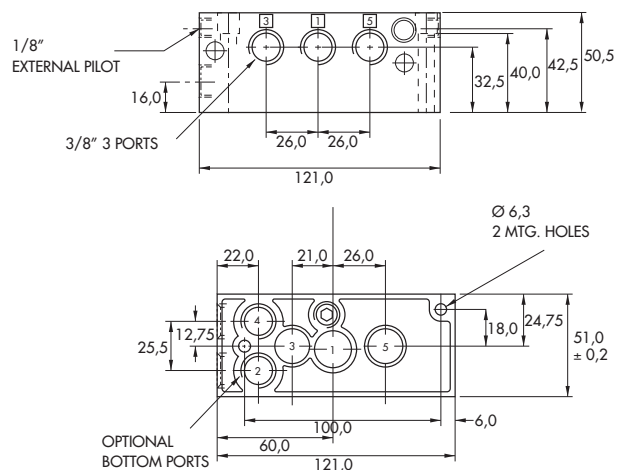

**Plug-in base / manifold**



- ISO 01
- ISO 02
- ISO 1**
- ISO 2
- ISO 3

**HOW TO ORDER**

INDIVIDUAL BASE

Port size	Wired for	Side ports	Side ports w/ bottom 2 & 4 ports	All side & bottom ports
<b>1/4" NPTF</b>	Single solenoid	MB-P1A-221-A	MB-P1A-222-A	MB-P1A-223-A
	Double solenoid	MB-P1A-221-B	MB-P1A-222-B	MB-P1A-223-B
<b>3/8" NPTF</b>	Single solenoid	MB-P1A-231-A	MB-P1A-232-A	MB-P1A-233-A
	Double solenoid	MB-P1A-231-B	MB-P1A-232-B	MB-P1A-233-B

MANIFOLD BASE

Port size	Wired for	Side ports	Side ports w/ bottom 2 & 4 ports	All side & bottom ports (see note)
<b>1/4" NPTF</b>	Single solenoid	MM-P1A-221-A	MM-P1A-222-A	MM-P1A-223-A
	Double solenoid	MM-P1A-221-B	MM-P1A-222-B	MM-P1A-223-B
<b>3/8" NPTF</b>	Single solenoid	MM-P1A-231-A	MM-P1A-232-A	MM-P1A-233-A
	Double solenoid	MM-P1A-231-B	MM-P1A-232-B	MM-P1A-233-B

Note : Ports 1, 3 & 5 are always 3/8"

**OPTIONS**

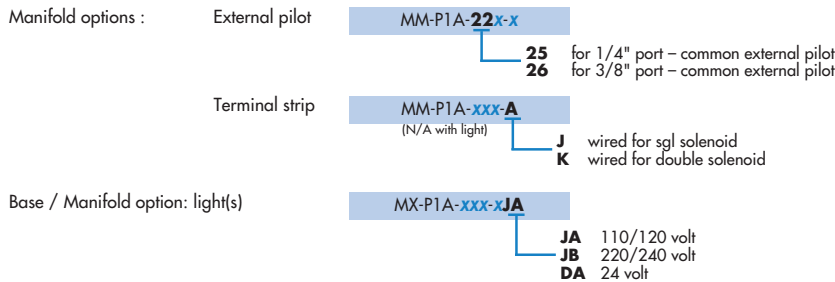

- Accessories: M-P1001 Valve blanking plate.  
N-P1007-01 Manifold fastening kit.  
32835 Inlet/exhaust isolator plug.

**DIMENSIONS**

Dimensions shown are metric (mm)

Individual

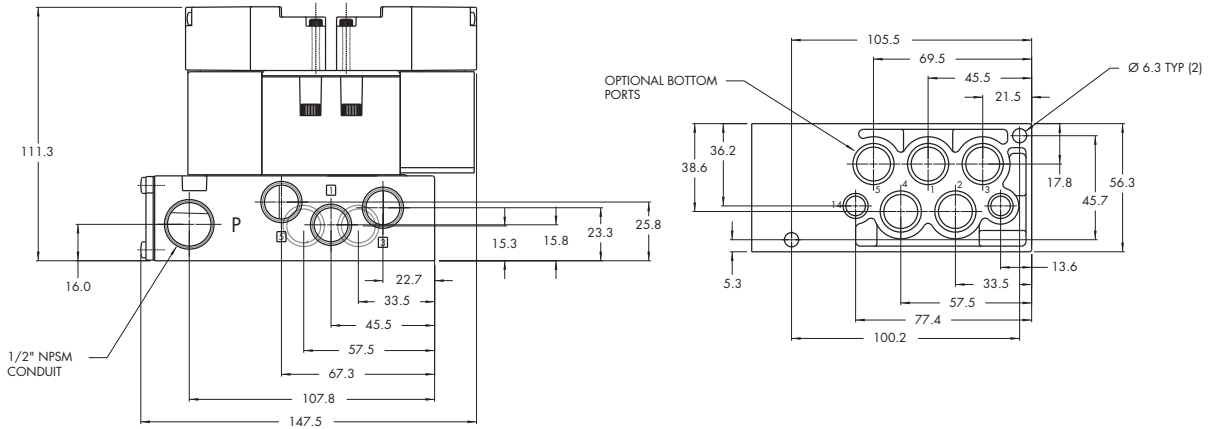

Manifold

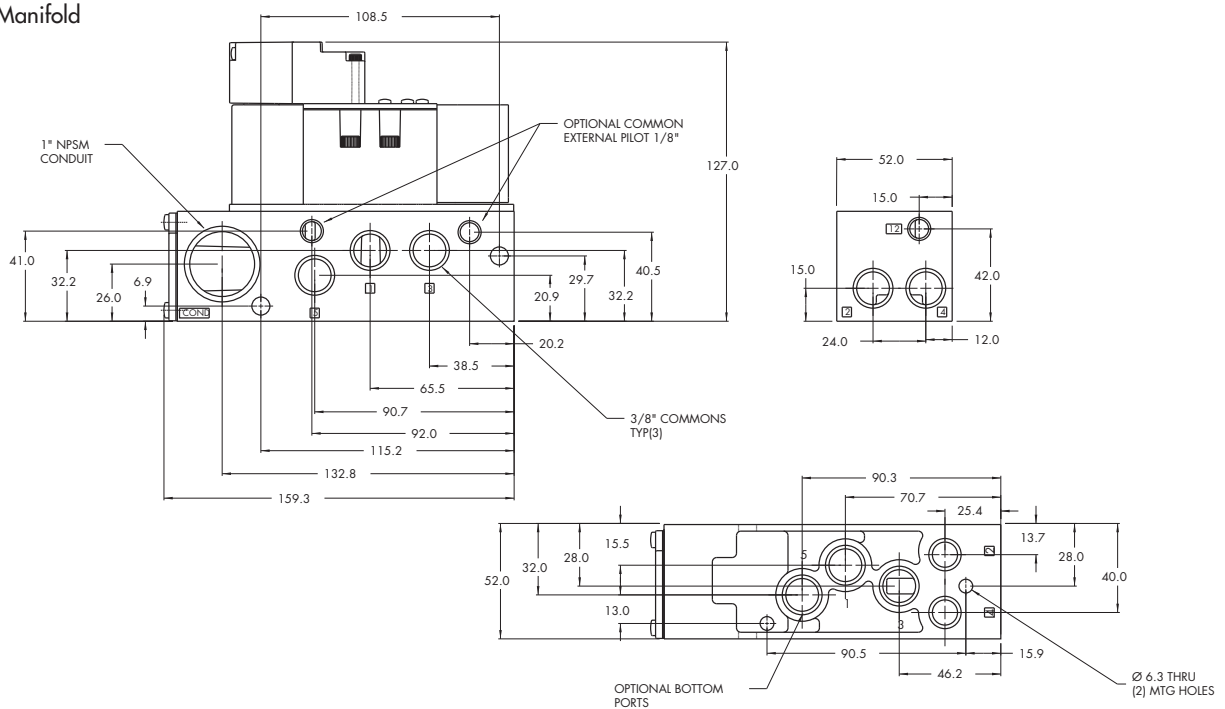

**Non plug-in base / manifold**



- ISO 01
- ISO 02
- ISO 1
- ISO 2**
- ISO 3

**HOW TO ORDER**

INDIVIDUAL BASE

Port size	Side ports	Bottom ports	Bottom cylinder ports 2 and 4.	Bottom inlet port 1
<b>3/8" NPTF</b>	MB-A2B-221	MB-A2B-223	MB-A2B-222	MB-A2B-224
<b>1/2" NPTF</b>	MB-A2B-231	MB-A2B-233	MB-A2B-232	MB-A2B-234

MANIFOLD BASE

Port size	Side ports	Bottom ports	Bottom cylinder ports 2 and 4.	Bottom inlet port 1
<b>3/8" NPTF</b>	MM-A2B-221	MM-A2B-223	MM-A2B-222	MM-A2B-224
<b>1/2" NPTF</b>	MM-A2B-231	MM-A2B-233	MM-A2B-232	MM-A2B-234

Manifold fastening kit : N-63002-01.  
 Valve blanking plate: MA2003.  
 Inlet/exhaust isolator plug: 32839.

**DIMENSIONS**

Dimensions shown are metric (mm)

Individual

DIN 5599/1

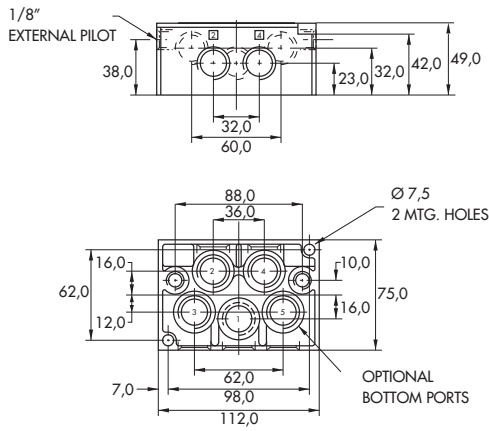

Manifold

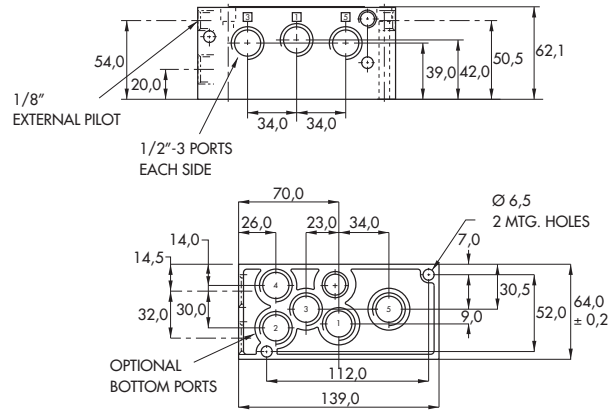

**Plug-in base / manifold**



- ISO 01
- ISO 02
- ISO 1
- ISO 2**
- ISO 3

**HOW TO ORDER**

INDIVIDUAL BASE

Port size	Wired for	Side ports	Side ports w/ bottom 2 & 4 ports	All side & bottom ports
<b>3/8" NPTF</b>	Single solenoid	MB-P2A-221-A	MB-P2A-222-A	MB-P2A-223-A
	Double solenoid	MB-P2A-221-B	MB-P2A-222-B	MB-P2A-223-B
<b>1/2" NPTF</b>	Single solenoid	MB-P2A-231-A	MB-P2A-232-A	MB-P2A-233-A
	Double solenoid	MB-P2A-231-B	MB-P2A-232-B	MB-P2A-233-B

MANIFOLD BASE

Port size	Wired for	Side ports	Side ports w/ bottom 2 & 4 ports	All side & bottom ports (see note)
<b>3/8" NPTF</b>	Single solenoid	MM-P2A-221-A	MM-P2A-222-A	MM-P2A-223-A
	Double solenoid	MM-P2A-221-B	MM-P2A-222-B	MM-P2A-223-B
<b>1/2" NPTF</b>	Single solenoid	MM-P2A-231-A	MM-P2A-232-A	MM-P2A-233-A
	Double solenoid	MM-P2A-231-B	MM-P2A-232-B	MM-P2A-233-B

Note : Ports 1, 3 & 5 are always 1/2"

**OPTIONS**

- Manifold options :
- External pilot **MM-P2A-22x-x**
    - 25** for 3/8" port – common external pilot
    - 26** for 1/2" port – common external pilot
  - Terminal strip **MM-P2A-xxx-A**
    - (N/A with light)
    - J** wired for sgl solenoid
    - K** wired for double solenoid
  - Base / Manifold option: light(s) **MX-P2A-xxx-xJA**
    - JA** 110/120 volt
    - JB** 220/240 volt
    - DA** 24 volt

- Accessories: M-P2001 Valve blanking plate.  
 N-P2004-01 Manifold fastening kit.  
 32839 Inlet/exhaust isolator plug.

**DIMENSIONS**

Dimensions shown are metric (mm)

**Individual**

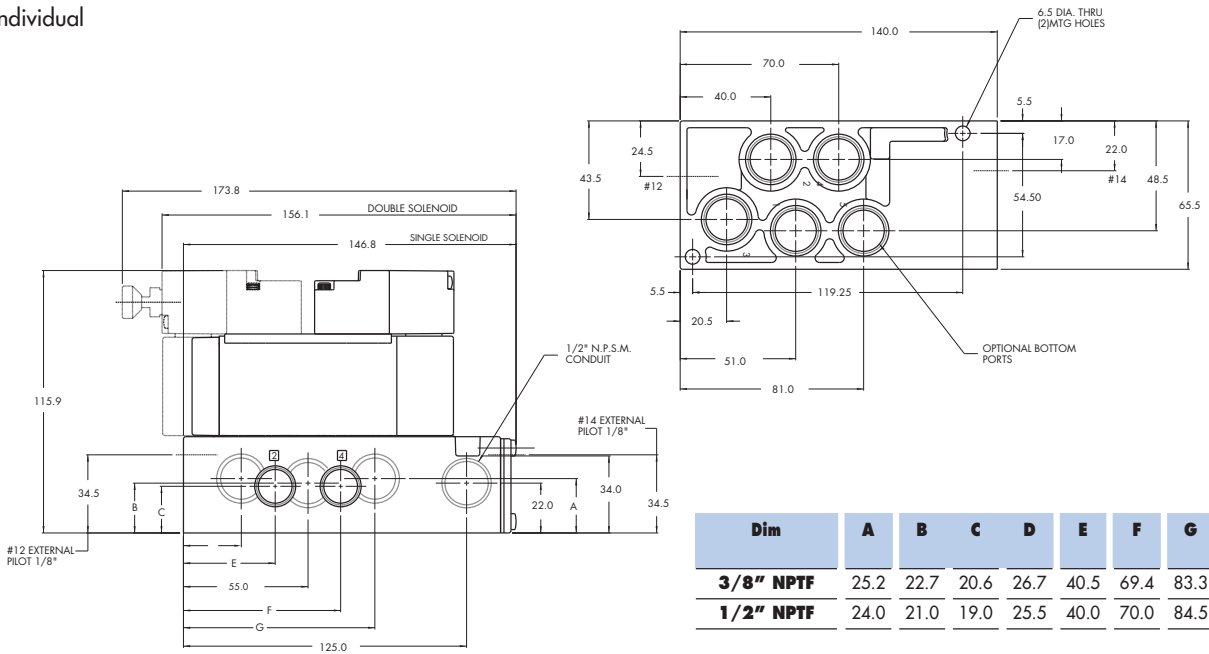

**Manifold**

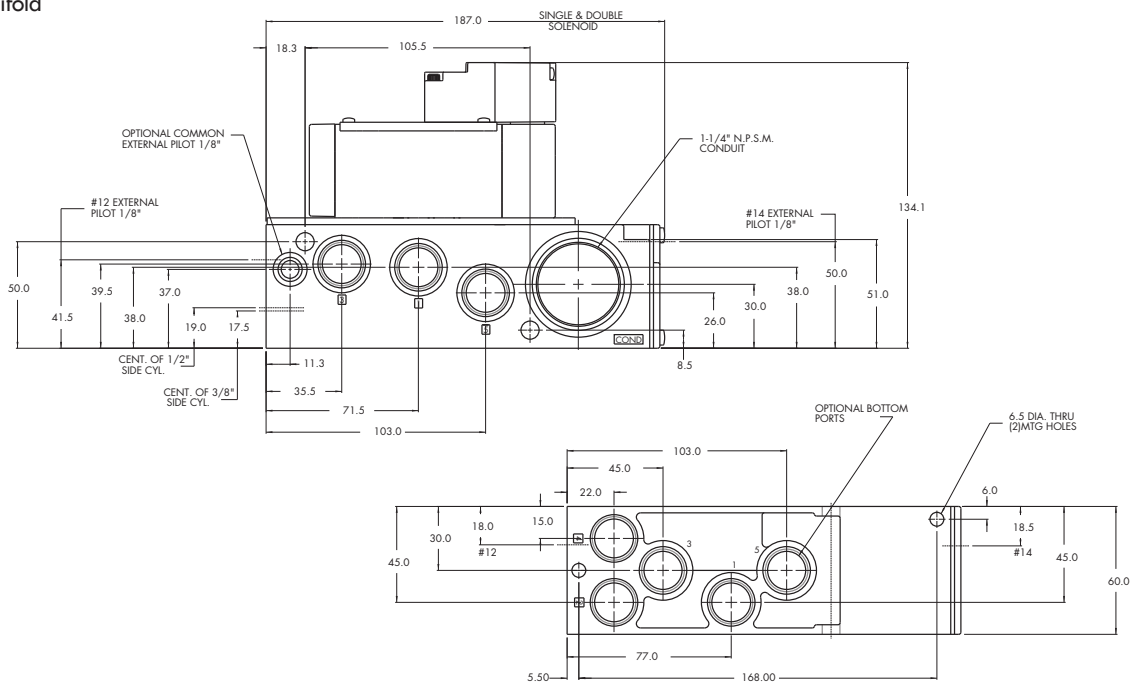

**Non plug-in base / manifold**

- ISO 01
- ISO 02
- ISO 1
- ISO 2
- ISO 3**



**HOW TO ORDER**

INDIVIDUAL BASE

Port size	Side ports	Bottom ports	Bottom cylinder ports 2 and 4.	Bottom inlet port 1
1/2" NPTF	MB-A3B-221	MB-A3B-223	MB-A3B-222	MB-A3B-224
3/4" NPTF	MB-A3B-231	MB-A3B-233	MB-A3B-232	MB-A3B-234

MANIFOLD BASE

Port size	Side ports	Bottom ports	Bottom cylinder ports 2 and 4.	Bottom inlet port 1
1/2" NPTF	MM-B3A-221-A	MM-B3A-223-A	MM-B3A-222-A	MM-B3A-224-A
3/4" NPTF	MM-B3A-231-A	MM-B3A-233-A	MM-B3A-232-A	MM-B3A-234-A

Manifold fastening kit: N-P3003-01.  
 Valve blanking plate: M-P3001.  
 Inlet/exhaust isolator plug: 32845.

Individual Base Options:

MB-A3B-XXXF  Optional Integral Flow Controls



**DIMENSIONS**

Dimensions shown are metric (mm)

Individual

ISO DIN 5599/1

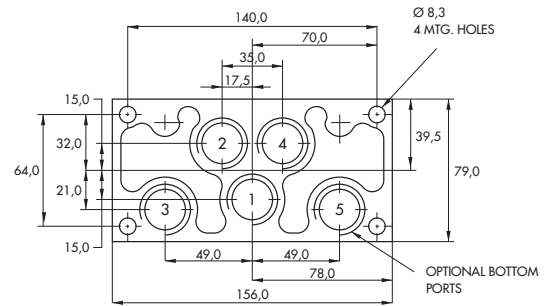
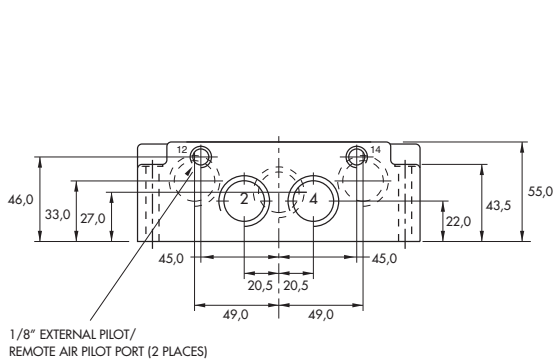

Manifold

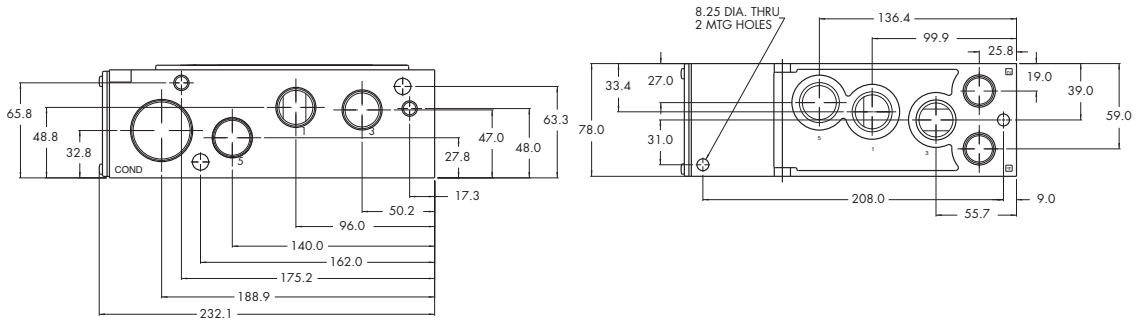
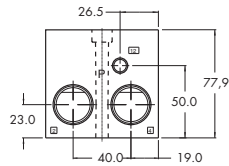

**Plug-in manifold**



- ISO 01
- ISO 02
- ISO 1
- ISO 2
- ISO 3**

**HOW TO ORDER**

MANIFOLD BASE

Port size	Wired for	Side ports	Side ports w/ bottom 2 & 4 ports	All side & bottom ports (see note)
<b>1/2" NPTF</b>	Single solenoid	MM-P3A-221-A	MM-P3A-222-A	MM-P3A-223-A
	Double solenoid	MM-P3A-221-B	MM-P3A-222-B	MM-P3A-223-B
<b>3/4" NPTF</b>	Single solenoid	MM-P3A-231-A	MM-P3A-232-A	MM-P3A-233-A
	Double solenoid	MM-P3A-231-B	MM-P3A-232-B	MM-P3A-233-B

Note : Ports 1, 3 & 5 are always 3/4"

**OPTIONS**

- Manifold options :
- External pilot **MM-P3A-22x-x**
    - 25** for 1/2" port - common external pilot
    - 26** for 3/4" port - common external pilot
  - Terminal strip **MM-P3A-xxx-A**
    - J** wired for sgl solenoid
    - K** wired for double solenoid
  - light(s) **MM-P3A-xxx-xJA**
    - JA** 110/120 volt
    - JB** 220/240 volt
    - DA** 24 volt

- Accessories:
- M-P3001 Valve blanking plate.
  - N-P3003-01 Manifold fastening kit.
  - 32845 Inlet/exhaust isolator plug.

**DIMENSIONS**

Dimensions shown are metric (mm)

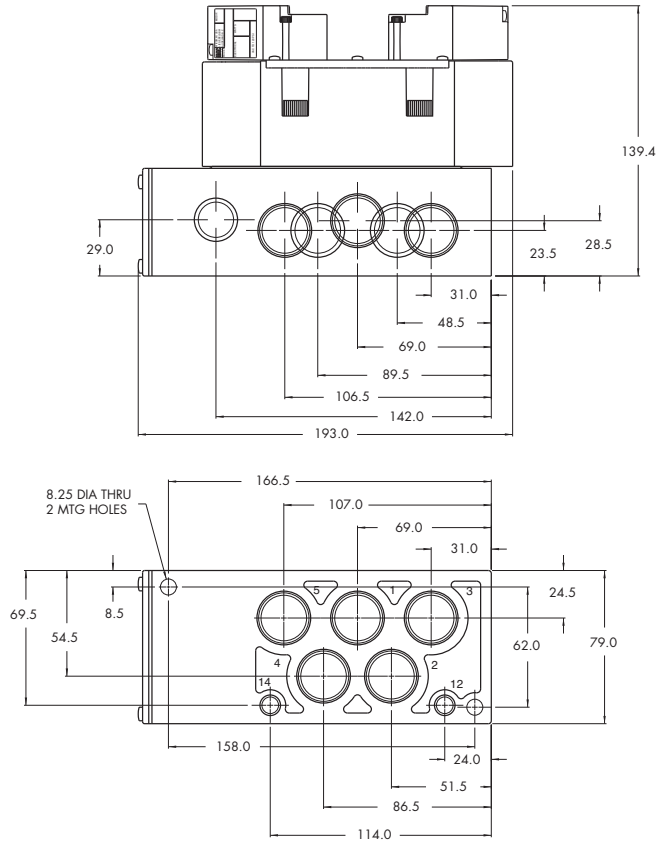



## Section 4

## Pressure regulators

---



<b>Sandwich pressure regulator with manual adjust knob</b>	P. 247	<b>PR37A</b>
<b>Sandwich pressure regulator with manual adjust knob</b>	P. 249	<b>PR42B</b>
<b>Sandwich pressure regulator</b>	P. 251	<b>PR46A</b>
<b>Sandwich pressure regulator with manual adjust knob</b>	P. 253	<b>PR47A</b>
<b>Sandwich pressure regulator with manual adjust knob</b>	P. 255	<b>PR48B</b>
<b>Sandwich pressure regulator with air pilot adjust</b>	P. 257	<b>PR92C</b>
<b>Sandwich pressure regulator with manual adjust knob</b>	P. 259	<b>PR93A</b>
<b>Sandwich pressure regulator with manual adjust knob</b>	P. 261	<b>PRA01A</b>
<b>Sandwich pressure regulator with air pilot adjust</b>	P. 263	<b>PRA02A</b>
<b>Sandwich pressure regulator with manual adjust knob</b>	P. 265	<b>PRA1A</b>
<b>Sandwich pressure regulator with manual adjust knob</b>	P. 267	<b>PRP1A</b>
<b>Non plug-in sandwich pressure regulator with manual adjust</b>	P. 269	<b>PRA2D</b>
<b>Plug-in sandwich pressure regulator with air pilot adjust</b>	P. 271	<b>PRP2B</b>
<b>Non plug-in sandwich pressure regulator with manual adjust</b>	P. 273	<b>PRA3C</b>
<b>Non plug-in sandwich pressure regulator with manual adjust knob</b>	P. 275	<b>PRP3B</b>
<b>Non plug-in sandwich pressure regulator with air pilot adjust</b>	P. 277	
<b>Plug-in sandwich pressure regulator with manual adjust knob</b>	P. 279	
<b>Plug-in sandwich pressure regulator with air pilot adjust</b>	P. 281	
<b>Non plug-in sandwich pressure regulator with manual adjust knob</b>	P. 283	
<b>Non plug-in sandwich pressure regulator with air pilot adjust</b>	P. 285	
<b>Plug-in sandwich pressure regulator with manual adjust knob</b>	P. 287	
<b>Plug-in sandwich pressure regulator with air pilot adjust</b>	P. 289	
<b>Non plug-in sandwich pressure regulator with manual adjust knob</b>	P. 291	
<b>Non plug-in sandwich pressure regulator with air pilot adjust</b>	P. 293	
<b>Plug-in sandwich pressure regulator with manual adjust knob</b>	P. 295	
<b>Plug-in sandwich pressure regulator with air pilot adjust</b>	P. 297	

**Sandwich pressure regulator with manual adjust knob**

**OPERATIONAL BENEFITS**

1. Easy mounting: saves on installation costs in comparison with inline regulators.
2. Compact all-included units.
3. Large orifice provides high flow.
4. Various functions available.
5. Simple, reliable and solid design.



**PR37A**

**PR42B**

**PR46A**

**PR47A**

**PR48B**

**PR92C**

**HOW TO ORDER**

REGULATORS FOR "NON PLUG-IN" VALVES (CODED FOR KNOB ADJUSTMENT)

Gage	Single pressure
<b>No gage port</b>	PR37A-FAAA
<b>With gage Port (plugged)</b>	PR37A-FABA

Note: Regulating pressure range for above models is 0 to 120 PSI  
For other ranges, see below.

**OPTIONS**

Adjustment :

PR37A-**Fxxx**  
B for slotted stem  
K for slotted stem with locknut

Pressure range :

PR37A-**xxxA**  
B for 0 to 80 PSI  
C for 0 to 30 PSI

**PR93A**

**PRA01A**

**PRA02A**

**PRA1A**

**PRP1A**

**PRA2D**

**PRP2B**

**PRA3C**

**PRP3B**

**TECHNICAL DATA**

<b>Fluid :</b>	Compressed air, inert gases
<b>Pressure range :</b>	0 to 120 PSI
<b>Regulating range :</b>	0 to 120 PSI
<b>Lubrication :</b>	Not required, if used select a medium aniline point lubricant (between 180°F to 210°F)
<b>Filtration :</b>	40 μ
<b>Temperature range :</b>	0°F to 120°F (-18°C to +50°C)
<b>Flow :</b>	0.4 C <sub>v</sub>

- Spare parts :
- Pressure regulator (less sandwich block) : PR37A-G0AA (knob), PR37A-C0AA (slotted stem), PR37A-L0AA (slotted stem with locknut)
  - Gages : 24177-160 (0 to 160 PSI, 23 mm)  
24177-100 (0 to 100 PSI, 23 mm)  
24177-060 (0 to 60 PSI, 23 mm)

**DIMENSIONS**

Dimensions shown are metric (mm)

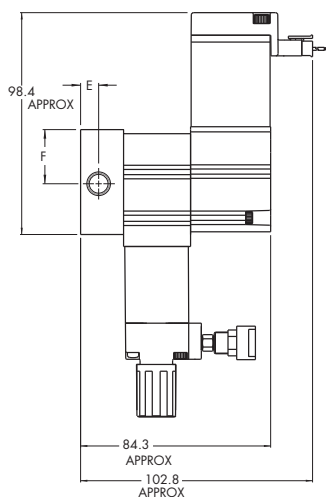

**Sandwich pressure regulator with manual adjust knob**

**OPERATIONAL BENEFITS**

1. Easy mounting: saves on installation costs in comparison with inline regulators.
2. Compact all-included units.
3. Large orifice provides high flow.
4. Various functions available.
5. Simple, reliable and solid design.



PR37A

**PR42B**

PR46A

PR47A

PR48B

PR92C

**HOW TO ORDER**

NON PLUG-IN SANDWICH REGULATORS

Gage	Regulator "1/2" end Internal pilot	Regulator "1/2" end External pilot
<b>No gage port</b>	PR42B-BAAA	PR42B-BBAA
<b>With gage Port</b>	PR42B-BABA	PR42B-BBBA

PR93A

PLUG-IN SANDWICH REGULATORS

Gage	Regulator "1/2" end Internal pilot	Regulator "1/2" end External pilot
<b>No gage port</b>	PR42B-AAAA	PR42B-ABAA
<b>With gage Port</b>	PR42B-AABA	PR42B-ABBA

PRA01A

PRA02A

PRA1A

PRP1A

PRA2D

PRP2B

PRA3C

PRP3B

Notes:

- External pilot regulator required only when supply pressure (primary) to the valve is below the minimum operating pressure of the 42 series valve.
- When an internal pilot regulator is used with the 42 series valve, the valve should be ordered as external pilot and the base should be ordered as internal pilot. This ensures that the pilot supply is not regulated. If an internal pilot valve and base are used with an internal pilot regulator, the pilot supply is regulated.

Example: Valve 42B-AM D -AA A -GxxP-xxx with PR42B-AAAA

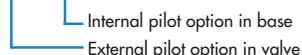

**OPTIONS**

Pressure range :

<b>PR42B-AAAA</b>	<b>A</b> 0 to 120 PSI
	<b>B</b> 0 to 80 PSI
	<b>C</b> 0 to 40 PSI



**TECHNICAL DATA**

<b>Fluid :</b>	Compressed air, inert gases
<b>Pressure range :</b>	0 to 120 PSI
<b>Regulating range :</b>	0 to 120 PSI
<b>Lubrication :</b>	Not required, if used select a medium aniline point lubricant (between 180°F to 210°F)
<b>Filtration :</b>	40 μ
<b>Temperature range :</b>	0°F to 120°F (-18°C to +50°C)
<b>Flow :</b>	0.25 C <sub>v</sub>

Spare parts :

- Pressure regulator (less sandwich block) : PR42B-C0xx • Gage port plug: N-PE003
- #10-32 to 1/8" adapter : N-35005 • Gage: 24177-160 (0 to 160 PSI, 23 mm)  
24177-100 (0 to 100 PSI, 23 mm)  
24177-060 (0 to 60 PSI, 23 mm)

**DIMENSIONS**

NON PLUG-IN

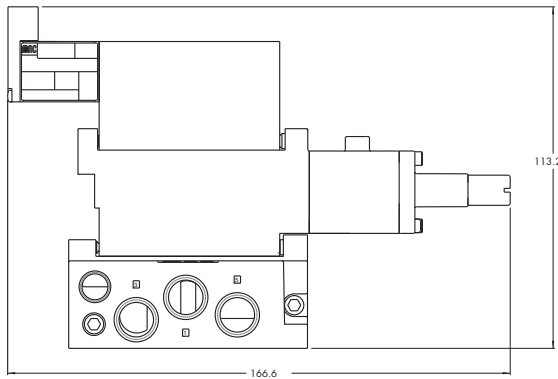

PLUG-IN

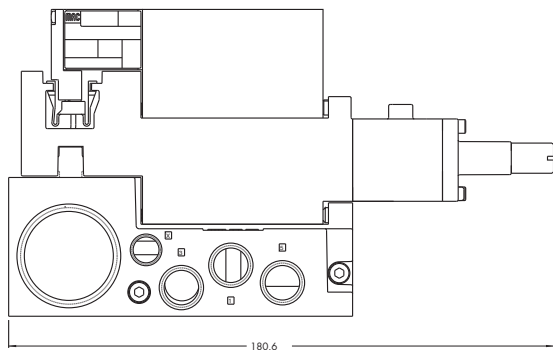

Dimensions shown are metric (mm)

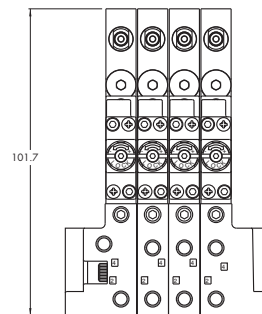

**Sandwich-pressure regulator**

**OPERATIONAL BENEFITS**

1. Easy mounting: saves on installation costs in comparison with inline regulators.
2. Compact all included units.
3. Large orifice provides high flow.
4. Various functions available.
5. Simple, reliable and solid design.
6. Single pressure regulator.



PR37A

PR42B

**PR46A**

PR47A

PR48B

PR92C

**HOW TO ORDER**

REGULATORS FOR "PLUG-IN" AND "NON PLUG-IN" VALVES

Gauge	For plug-in valves	For non plug-in valves
Gauge port (plugged)	PR46A-AAAA	PR46A-BAAA

PR93A

**OPTIONS**

Pressure range :

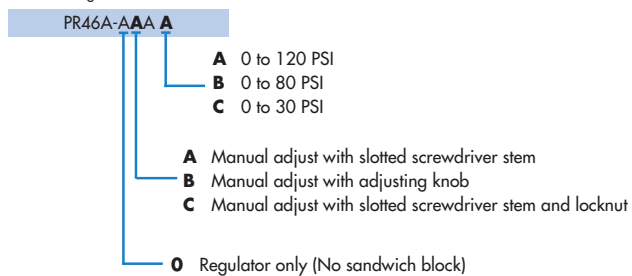

PRA01A

PRA02A

PRA1A

PRP1A

Notes : gages must be ordered separately, not included with regulator.  
 Recommended gage : 24165-150 (15 mm)

PRA2D

PRP2B

PRA3C

PRP3B

**TECHNICAL DATA**

<b>Fluid :</b>	Compressed air, inert gases
<b>Pressure range :</b>	0 to 120 PSI
<b>Regulating range :</b>	0 to 120 PSI
<b>Lubrication :</b>	Not required, if used select a medium aniline point lubricant (between 180°F and 210°F)
<b>Filtration :</b>	40 μ
<b>Temperature range :</b>	0°F to 120°F (-18°C to +50°C)
<b>Flow :</b>	Cv 0,21

**DIMENSIONS**

Dimensions shown are metric (mm)

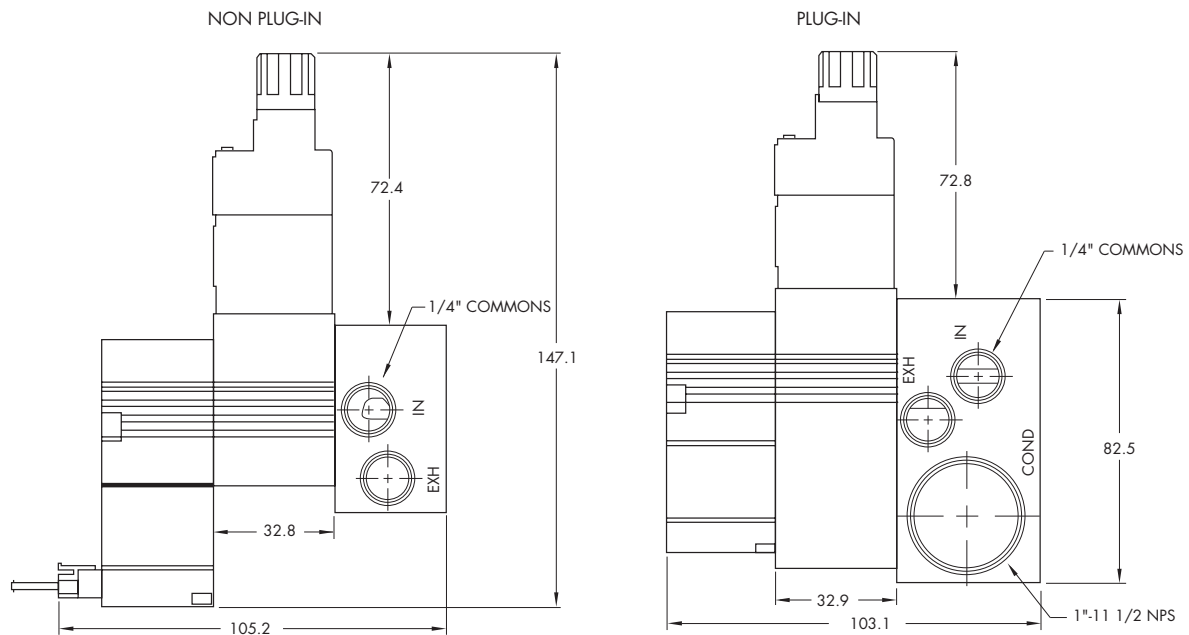

**Sandwich pressure regulator with manual adjust knob**

**OPERATIONAL BENEFITS**

1. Easy mounting: saves on installation costs in comparison with inline regulators.
2. Compact all-included units.
3. Large orifice provides high flow.
4. Various functions available.
5. Simple, reliable and solid design.



PR37A  
PR42B  
PR46A  
**PR47A**  
PR48B

PR92C

**HOW TO ORDER**

REGULATORS FOR "PLUG-IN" VALVES (KNOB ADJUSTMENT)

Gage	Single pressure
No gage port	PR47A-EAAA
With gage Port	PR47A-EABA

PR93A

REGULATORS FOR "NON PLUG-IN" VALVES (KNOB ADJUSTMENT)

Gage	Single pressure
No Gage port	PR47A-FAAA
With Gage Port	PR47A-FABA

PRA01A

PRA02A

**OPTIONS**

Pressure range :

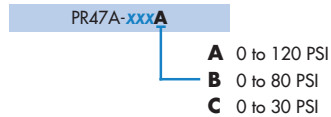

Adjustment for : Plug-in regulator

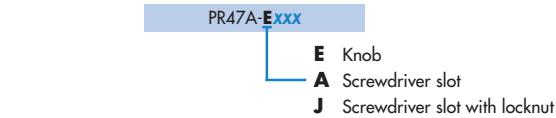

Non plug-in regulator

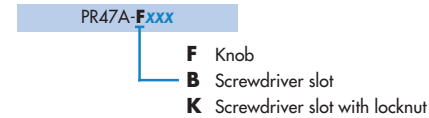

PRA1A

PRP1A

PRA2D

PRP2B

PRA3C

PRP3B

**TECHNICAL DATA**

<b>Fluid :</b>	Compressed air, inert gases
<b>Pressure range :</b>	0 to 120 PSI
<b>Regulating range :</b>	0 to 120 PSI
<b>Lubrication :</b>	Not required, if used select a medium aniline point lubricant (between 180°F to 210°F)
<b>Filtration :</b>	40 μ
<b>Temperature range :</b>	0°F to 120°F (-18°C to +50°C)
<b>Flow :</b>	0.4 C <sub>v</sub>

Spare parts :

- Pressure regulator (less sandwich block) : PR47A-G0AA (knob), PR47A-C0AA (screwdriver slot), PR47A-L0AA (screwdriver slot with locknut)
- Gage: 24177-160 (0 to 160 PSI, 23 mm)  
24177-100 (0 to 100 PSI, 23 mm)  
24177-060 (0 to 60 PSI, 23 mm)

**DIMENSIONS**

Dimensions shown are metric (mm)

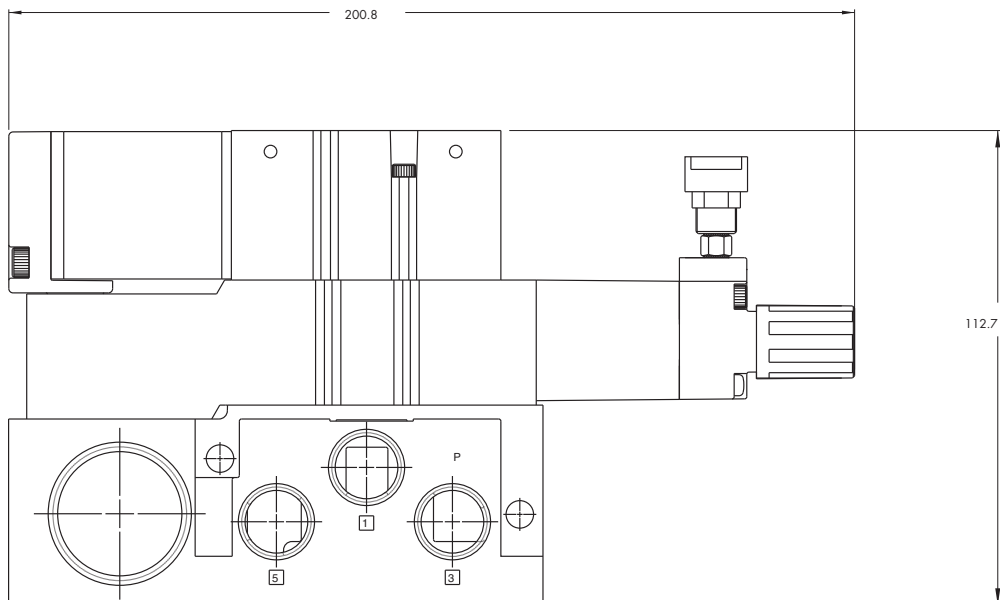

**Sandwich pressure regulator with manual adjust knob**

**OPERATIONAL BENEFITS**

1. Easy mounting: saves on installation costs in comparison with inline regulators.
2. Compact all-included units.
3. Large orifice provides high flow.
4. Various functions available.
5. Simple, reliable and solid design.



PR37A  
PR42B  
PR46A  
PR47A  
**PR48B**

PR92C

**HOW TO ORDER**

NON PLUG-IN SANDWICH REGULATORS (KNOB ADJUSTMENT)

Gage	Regulator "12" end Internal pilot	Regulator "12" end External pilot
Gage port	PR48B-BAAA	PR48B-BBAA

PR93A

PLUG-IN SANDWICH REGULATORS (KNOB ADJUSTMENT)

Gage	Regulator "12" end Internal pilot	Regulator "12" end External pilot
Gage port	PR48B-AAAA	PR48B-ABAA

PRA01A

PRA02A

PRA1A

PRP1A

PRA2D

PRP2B

PRA3C

PRP3B

Notes:

- External pilot regulator required only when supply pressure (primary) to the valve is below the minimum operating pressure of the 48 series valve.
- When an internal pilot regulator is used with the 48 series valve, the valve should be ordered as external pilot and the base should be ordered as internal pilot. This ensures that the pilot supply is not regulated. If an internal pilot valve and base are used with an internal pilot regulator, the pilot supply is regulated.

Example: Valve 48B-AM D-AA A-GxxP-xxx with PR48B-AAAA

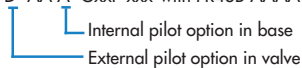

**OPTIONS**

Pressure range :

PR48B- <b>xxx</b> <b>A</b>	<b>A</b> 0 to 120 PSI
	<b>B</b> 0 to 80 PSI
	<b>C</b> 0 to 30 PSI

Adjustment for : Plug-in regulator

PR48B- <b>A</b> xxx	<b>A</b> Knob
	<b>D</b> Screwdriver slot
	<b>G</b> Screwdriver slot with locknut

Non plug-in regulator

PR48B- <b>B</b> xxx	<b>B</b> Knob
	<b>E</b> Screwdriver slot
	<b>H</b> Screwdriver slot with locknut

**TECHNICAL DATA**

<b>Fluid :</b>	Compressed air, inert gases
<b>Pressure range :</b>	0 to 120 PSI
<b>Regulating range :</b>	0 to 120 PSI
<b>Lubrication :</b>	Not required, if used select a medium aniline point lubricant (between 180°F to 210°F)
<b>Filtration :</b>	40 μ
<b>Temperature range :</b>	0°F to 120°F (-18°C to +50°C)
<b>Flow :</b>	0.8 C <sub>v</sub>

Spare parts :

- Pressure regulator (less sandwich block) : PR48B-C0AA (knob), PR48B-F0AA (screwdriver slot), PR48B-J0AA (screwdriver slot with locknut)
- Gage: 24177-160 (0 to 160 PSI, 23 mm)  
24177-100 (0 to 100 PSI, 23 mm)  
24177-060 (0 to 60 PSI, 23 mm)

**DIMENSIONS**

Dimensions shown are metric (mm)

NON PLUG-IN

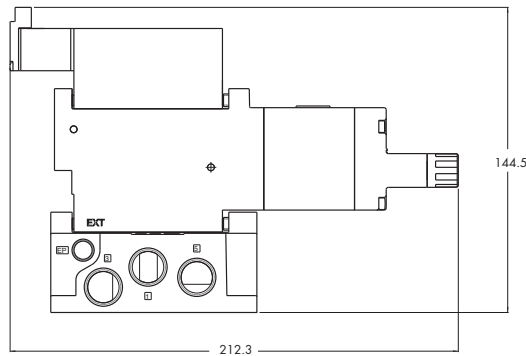

PLUG-IN

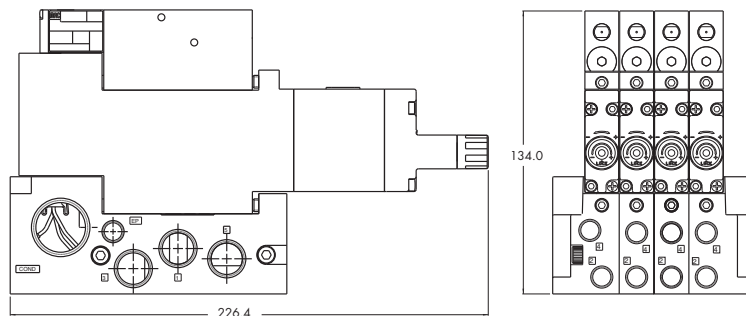

**Sandwich pressure regulator with air pilot adjust**

**OPERATIONAL BENEFITS**

1. Easy mounting: saves on installation costs in comparison with inline regulators.
2. Compact all-included units.
3. Large orifice provides high flow.
4. Various functions available.
5. Simple, reliable and solid design.



PR37A  
PR42B  
PR46A  
PR47A  
PR48B

**PR92C**

**HOW TO ORDER**

REGULATORS FOR "PLUG-IN" VALVES

Gage	Regulator A end Single pressure	Regulator B end Single pressure	Regulator A * end with by-pass end plate B end	Regulator B * end with by-pass end plate A end	Regulator * both ends
<b>Gage port only (plugged)</b>	PR92C-EAAA	PR92C-EBAA	PR92C-ECAA	PR92C-EDAA	PR92C-EEAA
<b>Gage with face perpendicular to manual operator</b>	PR92C-EABA	PR92C-EBBA	PR92C-ECBA	PR92C-EDBA	PR92C-EEBA
<b>Gage with face parallel to manual operator</b>	PR92C-EACA	PR92C-EBCA	PR92C-ECCA	PR92C-EDCA	PR92C-EECA

Note: above models are coded for use with single solenoid valves

REGULATORS FOR "NON PLUG-IN" VALVES

Gage	Regulator A end Single pressure	Regulator B end Single pressure	Regulator A * end with by-pass end plate B end	Regulator B * end with by-pass end plate A end	Regulator * both ends
<b>Gage port only (plugged)</b>	PR92C-GAAA	PR92C-GBAA	PR92C-GCAA	PR92C-GDAA	PR92C-GEAA
<b>Gage with face perpendicular to manual operator</b>	PR92C-GABA	PR92C-GBBA	PR92C-GCBA	PR92C-GDBA	PR92C-GEBA
<b>Gage with face parallel to manual operator</b>	PR92C-GACA	PR92C-GBCA	PR92C-GCCA	PR92C-GDCA	PR92C-GECA

\* For use with dual pressure valves.

**PLUG-IN OPTIONS**

PR92C-Exxx

— **F** for double solenoid valve

PR93A

PRA01A

PRA02A

PRA1A

PRP1A

PRA2D

PRP2B

PRA3C

PRP3B





100%  
OF  
PRODUCTION  
TESTED  
100%

WARRANTY  
18  
MONTHS

**TECHNICAL DATA**

<b>Fluid :</b>	Compressed air, inert gases
<b>Pressure range :</b>	0 to 120 PSI
<b>Regulating range :</b>	0 to 120 PSI
<b>Lubrication :</b>	Not required, if used select a medium aniline point lubricant (between 180°F to 210°F)
<b>Filtration :</b>	40 μ
<b>Temperature range :</b>	0°F to 120°F (-18°C to +50°C)
<b>Flow :</b>	0.8 C <sub>v</sub>

Spare parts :

- R-92003 : regulator end plate kit • Gage kit 0 - 160 PSI: N-92006-01
- R-92003-01 : regulator by-pass end plate kit
- Pressure regulator (less sandwich block) : PR92C-H0AA

**DIMENSIONS**

Dimensions shown are metric (mm)

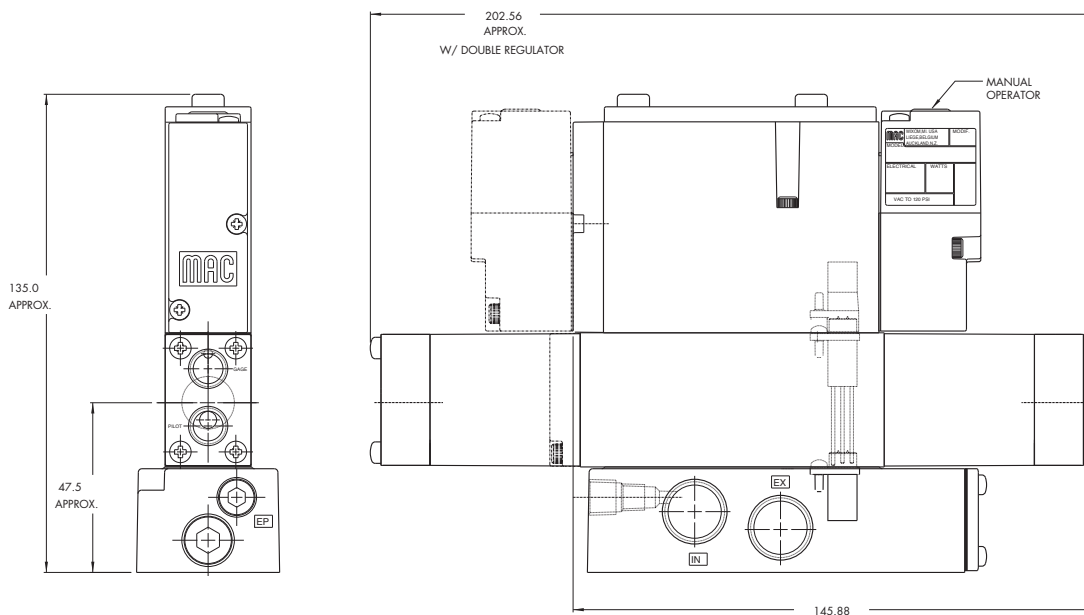

**Sandwich pressure regulator with manual adjust knob**

**OPERATIONAL BENEFITS**

1. Easy mounting: saves on installation costs in comparison with inline regulators.
2. Compact all-included units.
3. Large orifice provides high flow.
4. Various functions available.
5. Simple, reliable and solid design.



PR37A  
PR42B  
PR46A  
PR47A  
PR48B

**PR92C**

**HOW TO ORDER**

REGULATORS FOR "PLUG-IN" VALVES (CODED FOR KNOB ADJUSTMENT)

Gage	Regulator A end Single pressure	Regulator B end Single pressure	Regulator A * end with by-pass end plate B end	Regulator B * end with by-pass end plate A end	Regulator * both ends
<b>No Gage</b>	PR92C-JAAA	PR92C-JBAA	PR92C-JCAA	PR92C-JDAA	PR92C-JEAA
<b>Gage with face perpendicular to manual operator</b>	PR92C-JABA	PR92C-JBBA	PR92C-JCBA	PR92C-JDBA	PR92C-JEBA
<b>Gage with face parallel to manual operator</b>	PR92C-JACA	PR92C-JBCA	PR92C-JCCA	PR92C-JDCA	PR92C-JECA

Note: above models are coded for use with single solenoid valves

REGULATORS FOR "NON PLUG-IN" VALVES (CODED FOR KNOB ADJUSTMENT)

Gage	Regulator A end Single pressure	Regulator B end Single pressure	Regulator A * end with by-pass end plate B end	Regulator B * end with by-pass end plate A end	Regulator * both ends
<b>No Gage</b>	PR92C-LAAA	PR92C-LBAA	PR92C-LCAA	PR92C-LDAA	PR92C-LEAA
<b>Gage with face perpendicular to manual operator</b>	PR92C-LABA	PR92C-LBBA	PR92C-LCBA	PR92C-LDBA	PR92C-LEBA
<b>Gage with face parallel to manual operator</b>	PR92C-LACA	PR92C-LBCA	PR92C-LCCA	PR92C-LDCA	PR92C-LECA

\* For use with dual pressure valves.

Notes: - Regulating range for above models is 0 to 120 PSI. For other ranges, see technical data page.

**OPTIONS**

Regulator less sandwich block

PR92C-**x0xx**

- M** Knob
- D** Slotted stem
- S** Slotted stem with locknut

Other adjustment

PR92C-**xxxx**

- A** Slotted stem, single solenoid
- B** Slotted stem, double solenoid
- C** Slotted stem, non plug-in
- K** Knob, double solenoid
- N** Slotted stem w/ locknut, single solenoid
- P** Slotted stem w/ locknut, double solenoid
- R** Slotted stem w/ locknut, non plug-in

PR93A

PRA01A

PRA02A

PRA1A

PRP1A

PRA2D

PRP2B

PRA3C

PRP3B

**TECHNICAL DATA**

<b>Fluid :</b>	Compressed air, inert gases
<b>Pressure range :</b>	0 to 120 PSI
<b>Regulating range :</b>	0 to 120 PSI
<b>Lubrication :</b>	Not required, if used select a medium aniline point lubricant (between 180°F to 210°F)
<b>Filtration :</b>	40 μ
<b>Temperature range :</b>	0°F to 120°F (-18°C to +50°C)
<b>Flow :</b>	0.8 C <sub>v</sub>

- Spare parts :
- R-92003 : end plate kit • R-92003-01 : by-pass end plate kit
  - Gage kit 0 – 160 PSI : N-92006-01 • Gage kit 0 – 100 PSI : N-92006-02
  - Gage kit 0 – 60 PSI : N-92006-03

- Options:
- Pressure range: PR92C-xxxA (A 0 to 120 PSI)
    - B 0 to 80 PSI
    - C 0 to 30 PSI
    - D 0 to 120 PSI "A" end, 0 to 80 PSI "B" end
    - E 0 to 120 PSI "B" end, 0 to 80 PSI "A" end
    - F 0 to 120 PSI "A" end, 0 to 30 PSI "B" end
    - G 0 to 120 PSI "B" end, 0 to 30 PSI "A" end
    - H 0 to 80 PSI "A" end, 0 to 30 PSI "B" end
    - J 0 to 80 PSI "B" end, 0 to 30 PSI "A" end

**DIMENSIONS**

Dimensions shown are metric (mm)

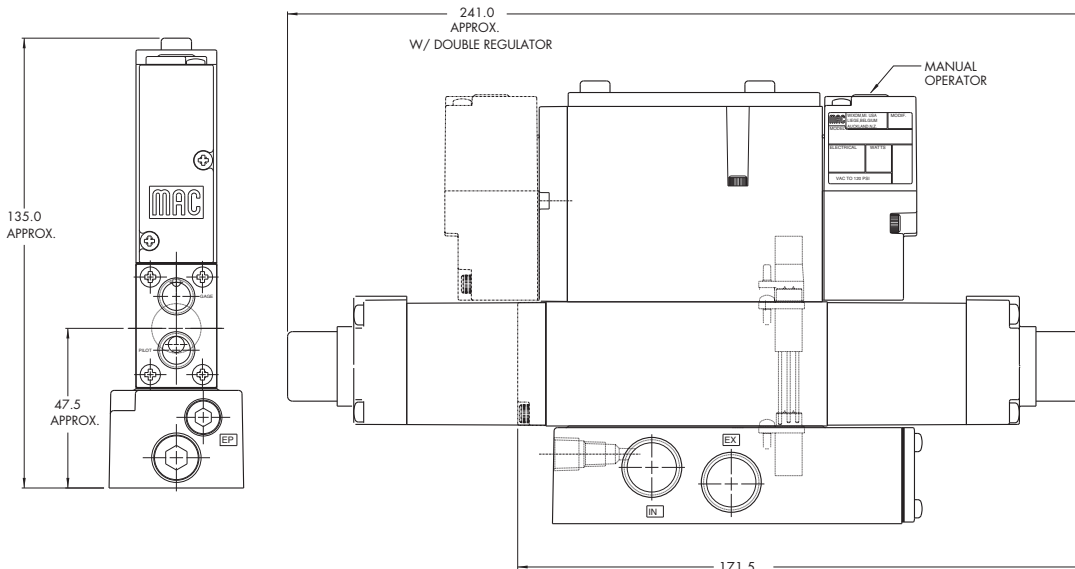

**Sandwich selector pressure regulator with manual adjust knob**

**OPERATIONAL BENEFITS**

1. Easy mounting: saves on installation costs in comparison with inline regulators.
2. Compact all-included units.
3. Large orifice provides high flow.
4. Various functions available.
5. Simple, reliable and solid design.



PR37A  
PR42B  
PR46A  
PR47A  
PR48B

**PR92C**

**HOW TO ORDER**

REGULATORS FOR "PLUG-IN" VALVES (CODED FOR KNOB ADJUSTMENT)

Gage	Select to A port Regulator A end By-pass plate B end	Select to B port Regulator B end By-pass plate A end	Select to A port Reg. both ends A end low press. B end high press.	Select to B port Reg. both ends A end high press. B end low press.
No Gage	PR92C-JPAA	PR92C-JRAA	PR92C-JSAA	PR92C-JTAA
Gage with face perpendicular to manual operator	PR92C-JPBA	PR92C-JRBA	PR92C-JSBA	PR92C-JTBA
Gage with face parallel to manual operator	PR92C-JPCA	PR92C-JRCA	PR92C-JSCA	PR92C-JTCA

PR93A

PRA01A

PRA02A

Note: above models are coded for use with single solenoid valves

REGULATORS FOR "NON PLUG-IN" VALVES (CODED FOR KNOB ADJUSTMENT)

Gage	Select to A port Regulator A end By-pass plate B end	Select to B port Regulator B end By-pass plate A end	Select to A port Reg. both ends A end low press. B end high press.	Select to B port Reg. both ends A end high press. B end low press.
No Gage	PR92C-LPAA	PR92C-LRAA	PR92C-LSAA	PR92C-LTAA
Gage with face perpendicular to manual operator	PR92C-LPBA	PR92C-LRBA	PR92C-LSBA	PR92C-LTBA
Gage with face parallel to manual operator	PR92C-LPCA	PR92C-LRCA	PR92C-LSCA	PR92C-LTCA

PRA1A

PRP1A

PRA2D

PRP2B

Notes: - Regulating range for above models is 0 to 120 PSI. For other ranges, see technical data page  
- Use single pressure valve for all above models.

**OPTIONS**

Regulator less sandwich block

- PR92C-x0xx
- M** Knob
  - D** Slotted stem
  - S** Slotted stem with locknut

Other adjustment

- PR92C-xxx
- A** Slotted stem, single solenoid
  - B** Slotted stem, double solenoid
  - C** Slotted stem, non plug-in
  - K** Knob, double solenoid
  - N** Slotted stem w/ locknut, single solenoid
  - P** Slotted stem w/ locknut, double solenoid
  - R** Slotted stem w/ locknut, non plug-in

PRA3C

PRP3B

**TECHNICAL DATA**

<b>Fluid :</b>	Compressed air, inert gases
<b>Pressure range :</b>	0 to 120 PSI
<b>Regulating range :</b>	0 to 120 PSI
<b>Lubrication :</b>	Not required, if used select a medium aniline point lubricant (between 180°F to 210°F)
<b>Filtration :</b>	40 μ
<b>Temperature range :</b>	0°F to 120°F (-18°C to +50°C)
<b>Flow :</b>	0.8 C <sub>v</sub>

- Spare parts :
- R-92003 : end plate kit • R-92003-01 : by-pass end plate kit
  - Gage kit 0 – 160 PSI : N-92006-01 • Gage kit 0 – 100 PSI : N-92006-02
  - Gage kit 0 – 60 PSI : N-92006-03

- Options :
- Pressure range: PR92C-xxxA (A 0 to 120 PSI)
    - B 0 to 80 PSI
    - C 0 to 30 PSI
    - D 0 to 120 PSI "A" end, 0 to 80 PSI "B" end
    - E 0 to 120 PSI "B" end, 0 to 80 PSI "A" end
    - F 0 to 120 PSI "A" end, 0 to 30 PSI "B" end
    - G 0 to 120 PSI "B" end, 0 to 30 PSI "A" end
    - H 0 to 80 PSI "A" end, 0 to 30 PSI "B" end
    - J 0 to 80 PSI "B" end, 0 to 30 PSI "A" end

**DIMENSIONS**

Dimensions shown are metric (mm)

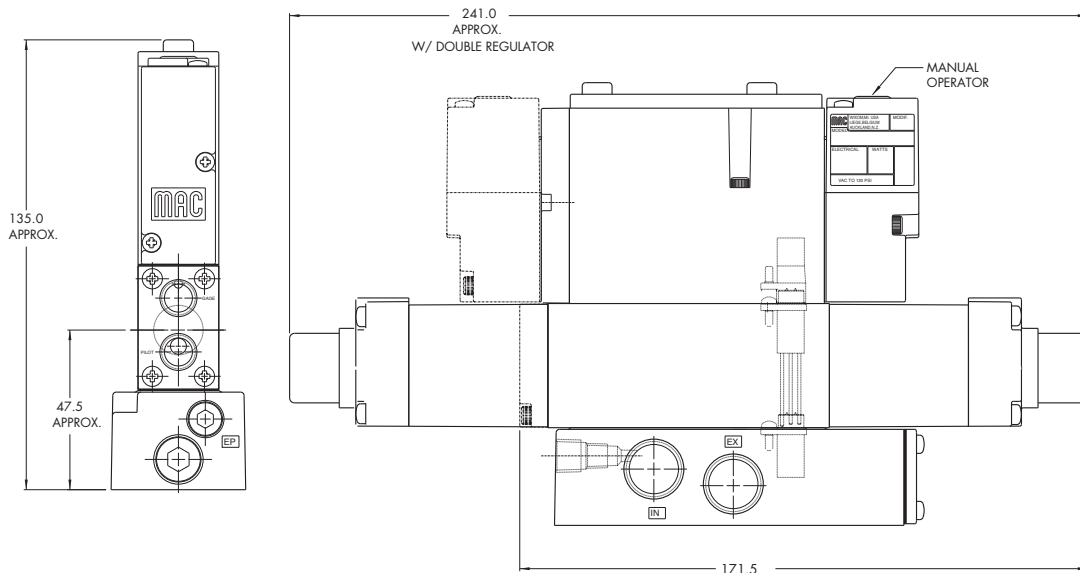

**Sandwich pressure regulator with air pilot adjust**

**OPERATIONAL BENEFITS**

1. Easy mounting: saves on installation costs in comparison with inline regulators.
2. Compact all-included units.
3. Large orifice provides high flow.
4. Various functions available.
5. Simple, reliable and solid design.



**PR37A**  
**PR42B**  
**PR46A**  
**PR47A**  
**PR48B**  
  
**PR92C**

**HOW TO ORDER**

REGULATORS FOR "PLUG-IN" VALVES

Gage	Regulator A end Single pressure	Regulator B end Single pressure	Regulator A * end with by-pass end plate B end	Regulator B * end with by-pass end plate A end	Regulator * both ends
<b>Gage port only (plugged)</b>	PR93A-DAAA	PR93A-DBAA	PR93A-DCAA	PR93A-DDAA	PR93A-DEAA
<b>Gage with face perpendicular to manual operator</b>	PR93A-DABA	PR93A-DBBA	PR93A-DCBA	PR93A-DDBA	PR93A-DEBA
<b>Gage with face parallel to manual operator</b>	PR93A-DACA	PR93A-DBCA	PR93A-DCCA	PR93A-DDCA	PR93A-DECA

**PR93A**

**PRA01A**

**PRA02A**

REGULATORS FOR "NON PLUG-IN" VALVES

Gage	Regulator A end Single pressure	Regulator B end Single pressure	Regulator A * end with by-pass end plate B end	Regulator B * end with by-pass end plate A end	Regulator * both ends
<b>Gage port only (plugged)</b>	PR93A-EAAA	PR93A-EBAA	PR93A-ECAA	PR93A-EDAA	PR93A-EEAA
<b>Gage with face perpendicular to manual operator</b>	PR93A-EABA	PR93A-EBBA	PR93A-ECBA	PR93A-EDBA	PR93A-EEBA
<b>Gage with face parallel to manual operator</b>	PR93A-EACA	PR93A-EBCA	PR93A-ECCA	PR93A-EDCA	PR93A-EECA

**PRA1A**

**PRP1A**

**PRA2D**

**PRP2B**

**PRA3C**

**PRP3B**

Note: Above models may be used with either single or double solenoid valves.  
 \* For use with dual pressure valves.

**TECHNICAL DATA**

<b>Fluid :</b>	Compressed air, inert gases
<b>Pressure range :</b>	0 to 120 PSI
<b>Regulating range :</b>	0 to 120 PSI
<b>Lubrication :</b>	Not required, if used select a medium aniline point lubricant (between 180°F to 210°F)
<b>Filtration :</b>	40 μ
<b>Temperature range :</b>	0°F to 120°F (-18°C to +50°C)
<b>Flow :</b>	2.4 C <sub>v</sub>

- Spare parts :
- Regulator end plate kit: R-93004 • Regulator by-pass end plate kit: R-93004-01
  - Gage kit: N-92006-01 (0 to 160 PSI)
  - Pressure regulator (less sandwich block): PR93A-F0AA

**DIMENSIONS**

Dimensions shown are metric (mm)

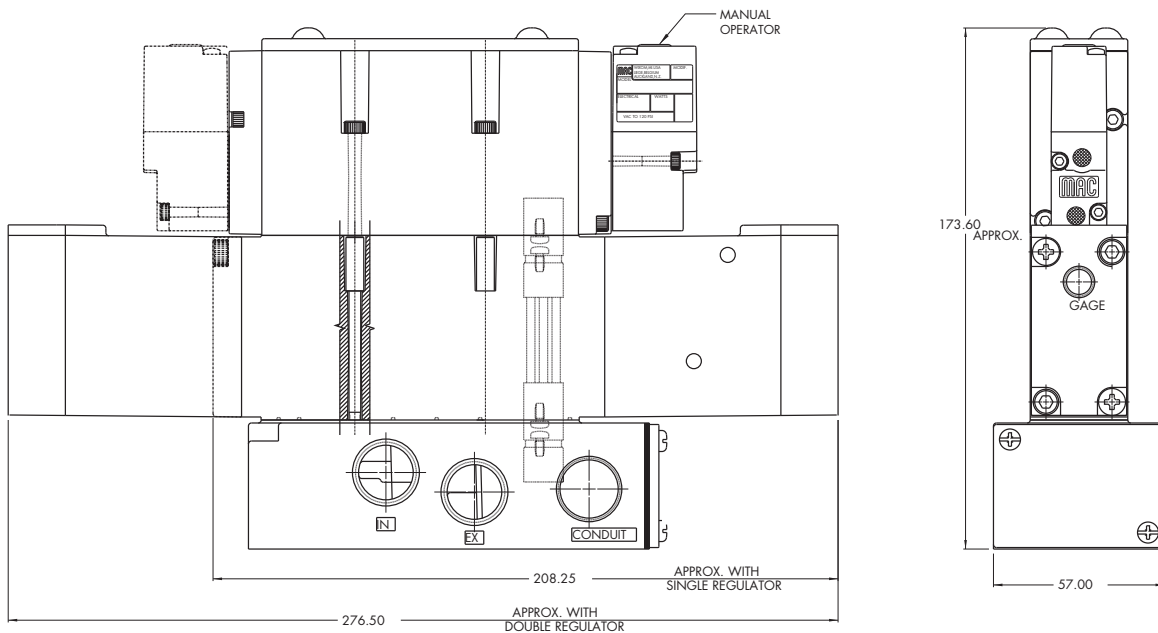

**Sandwich pressure regulator with manual adjust knob**

**OPERATIONAL BENEFITS**

1. Easy mounting: saves on installation costs in comparison with inline regulators.
2. Compact all-included units.
3. Large orifice provides high flow.
4. Various functions available.
5. Simple, reliable and solid design.



**PR37A**  
**PR42B**  
**PR46A**  
**PR47A**  
**PR48B**  
  
**PR92C**

**HOW TO ORDER**

REGULATORS FOR "PLUG-IN" VALVES (CODED FOR KNOB ADJUSTMENT)

Gage	Regulator A end Single pressure	Regulator B end Single pressure	Regulator A * end with by-pass end plate B end	Regulator B * end with by-pass end plate A end	Regulator * both ends
<b>Gage port only (plugged)</b>	PR93A-GAAA	PR93A-GBAA	PR93A-GCAA	PR93A-GDAA	PR93A-GEAA
<b>Gage with face perpendicular to manual operator</b>	PR93A-GABA	PR93A-GBBA	PR93A-GCBA	PR93A-GDBA	PR93A-GEBA
<b>Gage with face parallel to manual operator</b>	PR93A-GACA	PR93A-GBCA	PR93A-GCCA	PR93A-GDCA	PR93A-GECA

**PR93A**

REGULATORS FOR "NON PLUG-IN" VALVES (CODED FOR KNOB ADJUSTMENT)

Gage	Regulator A end Single pressure	Regulator B end Single pressure	Regulator A * end with by-pass end plate B end	Regulator B * end with by-pass end plate A end	Regulator * both ends
<b>Gage port only (plugged)</b>	PR93A-HAAA	PR93A-HBAA	PR93A-HCAA	PR93A-HDAA	PR93A-HEAA
<b>Gage with face perpendicular to manual operator</b>	PR93A-HABA	PR93A-HBBA	PR93A-HCBA	PR93A-HDBA	PR93A-HEBA
<b>Gage with face parallel to manual operator</b>	PR93A-HACA	PR93A-HBCA	PR93A-HCCA	PR93A-HDCA	PR93A-HECA

**PRA01A**

**PRA02A**

**PRA1A**

**PRP1A**

**PRA2D**

**PRP2B**

\* For use with dual pressure valves.

Note: Regulating range for above models is 0 to 120 PSI. For other ranges, see technical data page.

**OPTIONS**

Regulator less sandwich block

PR93A-x0xx

- J** Knob
- C** Slotted stem
- M** Slotted stem with locknut

Other adjustment

PR93A-xxx

- A** Slotted stem, plug-in
- B** Slotted stem, non plug-in
- K** Slotted stem w/ locknut, plug-in
- L** Slotted stem w/ locknut, non plug-in

**PRA3C**

**PRP3B**

Note: Above models may be used with either single or double solenoid valves.



**TECHNICAL DATA**

<b>Fluid :</b>	Compressed air, inert gases
<b>Pressure range :</b>	0 to 120 PSI
<b>Regulating range :</b>	0 to 120 PSI
<b>Lubrication :</b>	Not required, if used select a medium aniline point lubricant (between 180°F to 210°F)
<b>Filtration :</b>	40 µ
<b>Temperature range :</b>	0°F to 120°F (-18°C to +50°C)
<b>Flow :</b>	2.4 C <sub>v</sub>

- Spare parts :
- Regulator end plate kit :R-93004 • Regulator by-pass end plate kit : R-93004-01.
  - Gage kit 0 – 160 PSI : N-92006-01 • Gage kit 0 – 100 PSI : N-92006-02
  - Gage kit 60 PSI : N-92006-03

- Option:
- Pressure range: PR93A-xxxA (A 0 to 120 PSI)

- B 0 to 80 PSI
- C 0 to 30 PSI
- D 0 to 120 PSI "A" end, 0 to 80 PSI "B" end
- E 0 to 120 PSI "B" end, 0 to 80 PSI "A" end
- F 0 to 120 PSI "A" end, 0 to 30 PSI "B" end
- G 0 to 120 PSI "B" end, 0 to 30 PSI "A" end
- H 0 to 80 PSI "A" end, 0 to 30 PSI "B" end
- J 0 to 80 PSI "B" end, 0 to 30 PSI "A" end

**DIMENSIONS**

Dimensions shown are metric (mm)

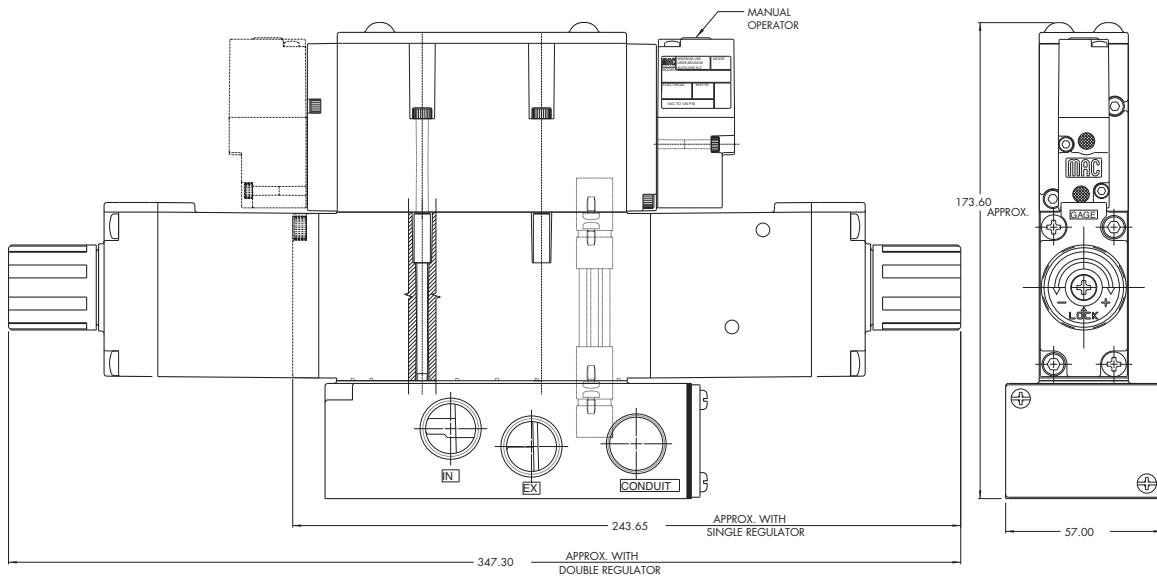

**Sandwich selector pressure regulator with manual adjust knob**

**OPERATIONAL BENEFITS**

1. Easy mounting: saves on installation costs in comparison with inline regulators.
2. Compact all-included units.
3. Large orifice provides high flow.
4. Various functions available.
5. Simple, reliable and solid design.



**PR37A**  
**PR42B**  
**PR46A**  
**PR47A**  
**PR48B**  
  
**PR92C**

**HOW TO ORDER**

REGULATORS FOR "PLUG-IN" VALVES (CODED FOR KNOB ADJUSTMENT)

Gage	Select to A port Regulator A end By-pass plate B end	Select to B port Regulator B end By-pass plate A end	Select to A port Reg. both ends A end low press. B end high press.	Select to B port Reg. both ends A end high press. B end low press.
<b>Gage port only (plugged)</b>	PR93A-GPAA	PR93A-GRAA	PR93A-GSAA	PR93A-GTAA
<b>Gage with face perpendicular to manual operator</b>	PR93A-GPBA	PR93A-GRBA	PR93A-GSBA	PR93A-GTBA
<b>Gage with face parallel to manual operator</b>	PR93A-GPCA	PR93A-GRCA	PR93A-GSCA	PR93A-GTCA

**PR93A**

**PRA01A**

**PRA02A**

REGULATORS FOR "NON PLUG-IN" VALVES

Gage	Select to A port Regulator A end By-pass plate B end	Select to B port Regulator B end By-pass plate A end	Select to A port Reg. both ends A end low press. B end high press.	Select to B port Reg. both ends A end high press. B end low press.
<b>Gage port only (plugged)</b>	PR93A-HPAA	PR93A-HRAA	PR93A-HSAA	PR93A-HTAA
<b>Gage with face perpendicular to manual operator</b>	PR93A-HPBA	PR93A-HRBA	PR93A-HSBA	PR93A-HTBA
<b>Gage with face parallel to manual operator</b>	PR93A-HPCA	PR93A-HRCA	PR93A-HSCA	PR93A-HTCA

**PRA1A**

**PRP1A**

**PRA2D**

Notes: - Regulating range for above models is 0 to 120 PSI. For other ranges, see technical data page  
 - Use single pressure valve for all above models.

**PRP2B**

**OPTIONS**

Regulator less sandwich block

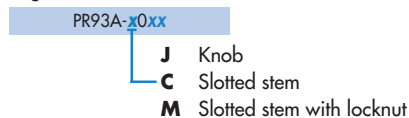

Other adjustment

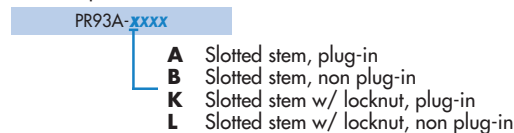

**PRA3C**

**PRP3B**

Note: Above models may be used with either single or double solenoid valves.

**TECHNICAL DATA**

<b>Fluid :</b>	Compressed air, inert gases
<b>Pressure range :</b>	0 to 120 PSI
<b>Regulating range :</b>	0 to 120 PSI
<b>Lubrication :</b>	Not required, if used select a medium aniline point lubricant (between 180°F to 210°F)
<b>Filtration :</b>	40 µ
<b>Temperature range :</b>	0°F to 120°F (-18°C to +50°C)
<b>Flow :</b>	2.4 C <sub>v</sub>

Spare parts :

- Regulator end plate kit :R-93004 • Regulator by-pass end plate kit : R-93004-01.
- Gage kit 0 – 160 PSI : N-92006-01 • Gage kit 0 – 100 PSI : N-92006-02
- Gage kit 0 – 60 PSI : N-92006-03

Option:

- Pressure range: PR93A-xxx~~A~~ (A 0 to 120 PSI)
  - B 0 to 80 PSI
  - C 0 to 30 PSI
  - D 0 to 120 PSI "A" end, 0 to 80 PSI "B" end
  - E 0 to 120 PSI "B" end, 0 to 80 PSI "A" end
  - F 0 to 120 PSI "A" end, 0 to 30 PSI "B" end
  - G 0 to 120 PSI "B" end, 0 to 30 PSI "A" end
  - H 0 to 80 PSI "A" end, 0 to 30 PSI "B" end
  - J 0 to 80 PSI "B" end, 0 to 30 PSI "A" end

**DIMENSIONS**

Dimensions shown are metric (mm)

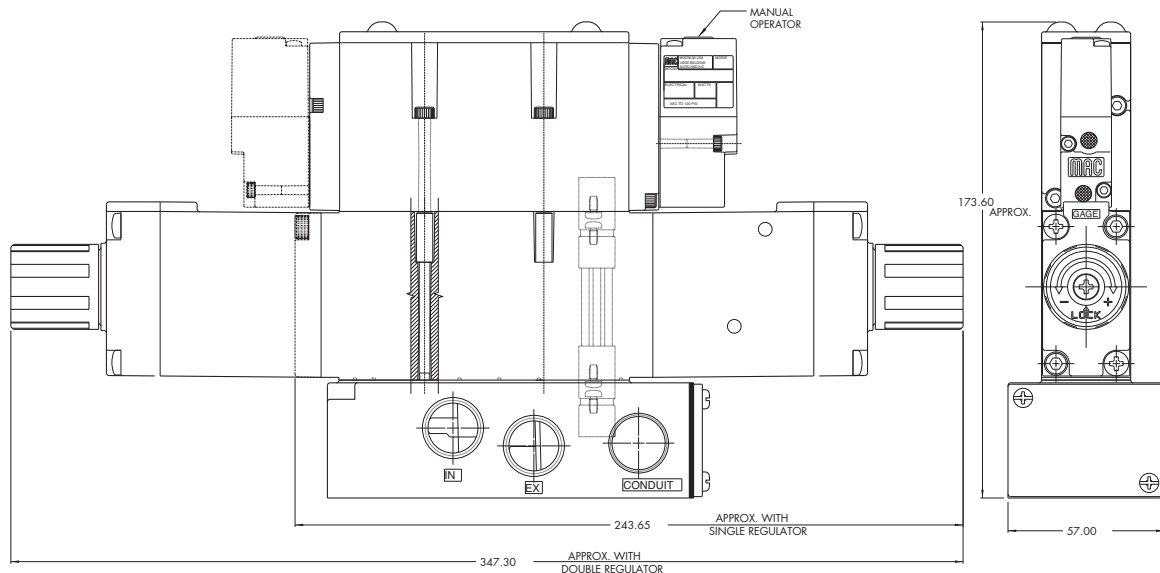

**Non plug-in sandwich pressure regulator with manual adjust**

**OPERATIONAL BENEFITS**

1. Easy mounting: saves on installation costs and space in comparison with inline regulators
2. Compact all-included units
3. Large orifice provides high flow
4. Various functions available
5. Simple, reliable and solid design



**PR37A**  
**PR42B**  
**PR46A**  
**PR47A**  
**PR48B**  
  
**PR92C**

**HOW TO ORDER**

Pilot	Single pressure Regulator 12 end	Dual pressure Regulator 12 end with by-pass 14 end	Dual pressure Regulator 14 end with by-pass 12 end	Dual pressure Regulator both ends
<b>Internal</b>	PRA01A-AAAA	PRA01A-ABAA	PRA01A-ADAA	PRA01A-AEAA
<b>External</b>	PRA01A-BAAA	PRA01A-BBAA	PRA01A-BDAA	PRA01A-BEAA

**PR93A**

Above models are for manual adjust with knob  
 For other manual adjustments and pressure ranges, see Options.

Note: Add -9 after part number for regulator block assembled to valve.  
 \* To be used with dual pressure valves.

**PRA01A**

**PRA02A**

**OPTIONS**

Adjustments :

PRA01A - **xxxx**

- A** Manual adjust with knob – Internal pilot
- B** Manual adjust with knob – External pilot
- G** Manual adjust with screwdriver slot – Internal pilot
- H** Manual adjust with screwdriver slot – External pilot
- K** Manual adjust with screwdriver slot with locknut– Internal pilot
- L** Manual adjust with screwdriver slot with locknut – External pilot

**PRA1A**

**PRP1A**

Regulated Pressure range :

PRA01A - **xxxx**

- A** 0 to 120 PSI
- B** 0 to 80 PSI
- C** 0 to 30 PSI
- D** 0 to 120 PSI "14" end - 0 to 80 PSI "12" end
- E** 0 to 120 PSI "12" end - 0 to 80 PSI "14" end
- F** 0 to 120 PSI "14" end - 0 to 30 PSI "12" end
- G** 0 to 120 PSI "12" end - 0 to 30 PSI "14" end
- H** 0 to 80 PSI "14" end - 0 to 30 PSI "12" end
- J** 0 to 80 PSI "12" end - 0 to 30 PSI "14" end

**PRA2D**

**PRP2B**

**PRA3C**

**PRP3B**

**TECHNICAL DATA**

<b>Fluid :</b>	Compressed air, inert gases
<b>Pressure supply :</b>	Higher than maximum regulated pressure (max. 8,5 bar)
<b>Regulating range :</b>	0 to 120 PSI
<b>Lubrication :</b>	Not required, if used select a medium aniline point lubricant (between 180°F and 210°F)
<b>Filtration :</b>	40 µ
<b>Temperature range :</b>	0°F to 120°F (-18°C to +50°C)

**DIMENSIONS**

Dimensions shown are metric (mm)

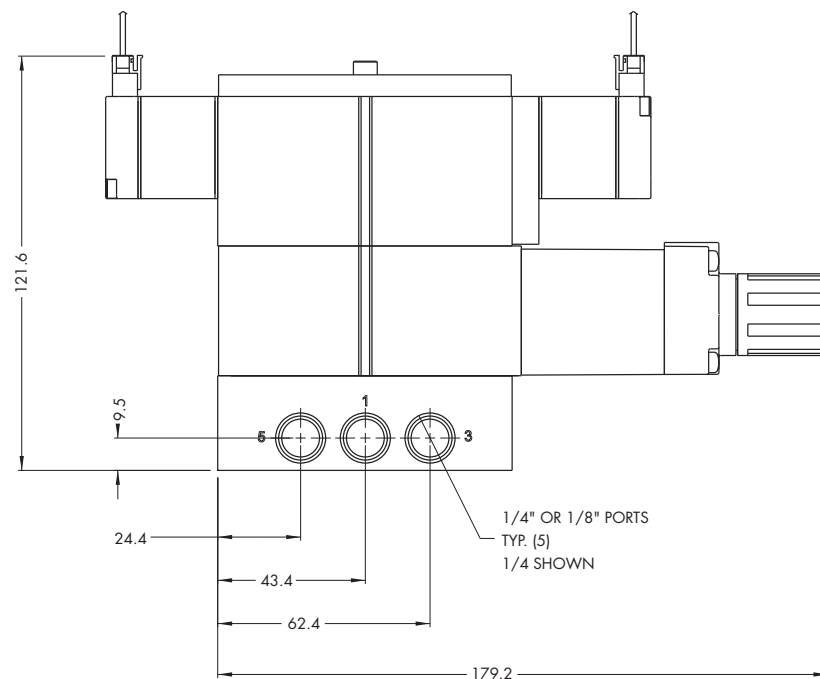



**Non plug-in sandwich pressure regulator with air pilot adjust**

**OPERATIONAL BENEFITS**

1. Easy mounting: saves on installation costs in comparison with inline regulators
2. Compact all-included units
3. Large orifice provides high flow
4. Various functions available
5. Simple, reliable and solid design

**PR37A**  
**PR42B**  
**PR46A**  
**PR47A**  
**PR48B**

**HOW TO ORDER**

Pilot	Single pressure Regulator 12 end	Dual pressure Regulator 12 end with by-pass 14 end *	Dual pressure Regulator 14 end with by-pass 12 end *	Dual pressure Regulator both ends *
<b>Internal</b>	PRA01A-DAAA	PRA01A-DBAA	PRA01A-DDAA	PRA01A-DEAA
<b>External</b>	PRA01A-EAAA	PRA01A-EBAA	PRA01A-EDAA	PRA01A-EEAA

**PR92C**

**PR93A**

Note : Only pressure range available for air adjust regulator is 0-120 PSI.  
 \* To be used with dual pressure valves.

**PRA01A**

**PRA02A**

**PRA1A**

**PRP1A**

**PRA2D**

**PRP2B**

**PRA3C**

**PRP3B**

**TECHNICAL DATA**

<b>Fluid :</b>	Compressed air, inert gases
<b>Pressure range :</b>	Higher than maximum regulated pressure
<b>Regulating range :</b>	0 to 120 PSI
<b>Lubrication :</b>	Not required, if used select a medium aniline point lubricant (between 180°F and 210°F)
<b>Filtration :</b>	40 μ
<b>Temperature range :</b>	0°F to 120°F (-18°C to +50°C)

**DIMENSIONS**

Dimensions shown are metric (mm)

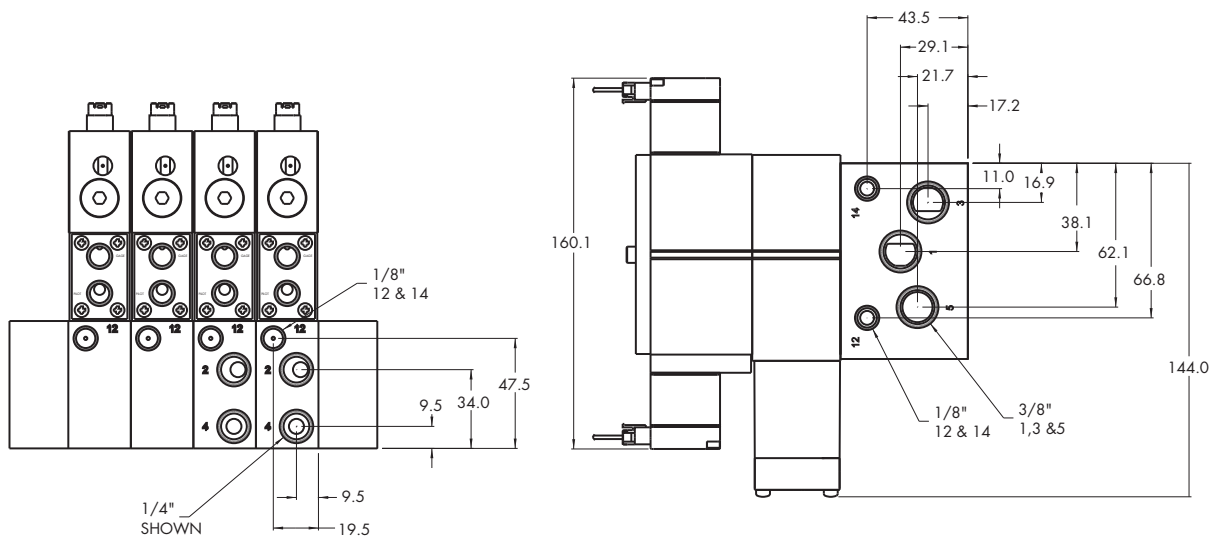

**Non plug-in sandwich pressure regulator with manual adjust**

**OPERATIONAL BENEFITS**

1. Easy mounting: saves on installation costs and space in comparison with inline regulators
2. Compact all-included units
3. Large orifice provides high flow
4. Various functions available
5. Simple, reliable and solid design



**PR37A**  
**PR42B**  
**PR46A**  
**PR47A**  
**PR48B**  
  
**PR92C**

**HOW TO ORDER**

Pilot	Single pressure Regulator 12 end	Dual pressure Regulator 12 end with by-pass 14 end	Dual pressure Regulator 14 end with by-pass 12 end	Dual pressure Regulator both ends
<b>Internal</b>	PRA02A-AAAA	PRA02A-ABAA	PRA02A-ADAA	PRA02A-AEAA
<b>External</b>	PRA02A-BAAA	PRA02A-BBAA	PRA02A-BDAA	PRA02A-BEAA

Above models are for manual adjust with knob  
 For other manual adjustments and pressure ranges, see Options.

Note: Add -9 after part number for regulator block assembled to valve.  
 \* To be used with dual pressure valves.

**PR93A**

**PRA01A**

**PRA02A**

**OPTIONS**

Adjustments :

PRA02A - **xxxx**

- A** Manual adjust with knob – Internal pilot
- B** Manual adjust with knob – External pilot
- G** Manual adjust with screwdriver slot – Internal pilot
- H** Manual adjust with screwdriver slot – External pilot
- K** Manual adjust with screwdriver slot with locknut– Internal pilot
- L** Manual adjust with screwdriver slot with locknut – External pilot

**PRA1A**

**PRP1A**

Regulated Pressure range :

PRA02A - **xxxx**

- A** 0 to 120 PSI
- B** 0 to 80 PSI
- C** 0 to 30 PSI
- D** 0 to 120 PSI "14" end - 0 to 80 PSI "12" end
- E** 0 to 120 PSI "12" end - 0 to 80 PSI "14" end
- F** 0 to 120 PSI "14" end - 0 to 30 PSI "12" end
- G** 0 to 120 PSI "12" end - 0 to 30 PSI "14" end
- H** 0 to 80 PSI "14" end - 0 to 30 PSI "12" end
- J** 0 to 80 PSI "12" end - 0 to 30 PSI "14" end

**PRA2D**

**PRP2B**

**PRA3C**

**PRP3B**



**TECHNICAL DATA**

<b>Fluid :</b>	Compressed air, inert gases
<b>Pressure supply :</b>	Higher than maximum regulated pressure
<b>Regulating range :</b>	0 to 120 PSI
<b>Lubrication :</b>	Not required, if used select a medium aniline point lubricant (between 180°F and 210°F)
<b>Filtration :</b>	40 μ
<b>Temperature range :</b>	0°F to 120°F (-18°C to +50°C)

**DIMENSIONS**

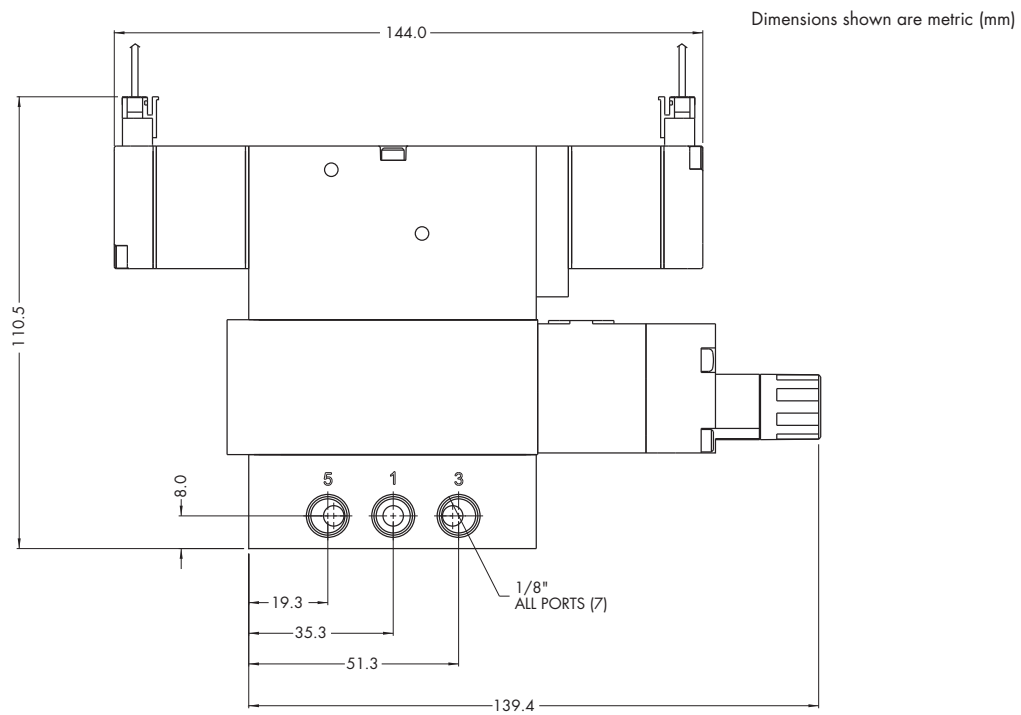

**Non plug-in sandwich pressure regulator with manual adjust knob**

**OPERATIONAL BENEFITS**

1. Easy mounting : saves on installation costs in comparison with inline regulators.
2. Allows to have compact, all-included units.
3. Large orifice provides high flow.
4. Various functions available.
5. Simple, reliable and solid design.



PR37A  
PR42B  
PR46A  
PR47A  
PR48B  
  
PR92C

**HOW TO ORDER**

INTERNAL PILOT

Gage	Single pressure Regulator 14 end Same regulated pressure to ports 2 and 4	Single pressure Regulator 12 end Same regulated pressure to ports 2 and 4	Dual pressure Regulator 14 end Regulated pressure to port 4 *	Dual pressure Regulator 12 end Regulated pressure to port 2 *	Dual pressure Dual regulator Two regulated pressures to ports 2 and 4 *
No gage	PRA1A-GAAA	PRA1A-GCAA	PRA1A-GBAA	PRA1A-GDAA	PRA1A-GEAA
Gage perpendicular to regulator(s)	PRA1A-GABA	PRA1A-GCBA	PRA1A-GBBA	PRA1A-GDBA	PRA1A-GECA
Gage parallel to regulator(s)	PRA1A-GADA	PRA1A-GCDA	PRA1A-GBDA	PRA1A-GDDA	PRA1A-GEEA

PR93A

PRA01A

PRA02A

EXTERNAL PILOT AND REMOTE AIR

Gage	Single pressure Regulator 14 end Same regulated pressure to ports 2 and 4	Single pressure Regulator 12 end Same regulated pressure to ports 2 and 4	Dual pressure Regulator 14 end Regulated pressure to port 4 *	Dual pressure Regulator 12 end Regulated pressure to port 2 *	Dual pressure Dual regulator Two regulated pressures to ports 2 and 4 *
No gage	PRA1A-HAAA	PRA1A-HCAA	PRA1A-HBAA	PRA1A-HDAA	PRA1A-HEAA
Gage perpendicular to regulator(s)	PRA1A-HABA	PRA1A-HCBA	PRA1A-HBBA	PRA1A-HDBA	PRA1A-HECA
Gage parallel to regulator(s)	PRA1A-HADA	PRA1A-HCDA	PRA1A-HBDA	PRA1A-HDDA	PRA1A-HEEA

PRA1A

PRP1A

PRA2D

PRP2B

PRA3C

PRP3B

\* - To be used with dual pressure valves.

Note : regulating range for above models is 0-120 PSI. For other ranges see technical data page.

Main valve body assembly must be external pilot model. Pilots are supplied internally from primary pressure in regulator block. Cannot field convert regulator block from Single Pressure to dual pressure. Body/Block to base mounting screw #35336.

**ADJUSTMENT OPTIONS**

PRA1A-xxxx

- A** for slotted stem adjustment (internal pilot)
- B** for slotted stem adjustment (external/remote air)
- K** for slotted stem with locknut (internal pilot)
- L** for slotted stem with locknut (external/remote air)

**TECHNICAL DATA**

<b>Fluid :</b>	Compressed air, inert gases
<b>Pressure range :</b>	0 to 150 PSI
<b>Regulating range :</b>	0 to 120 PSI (other ranges see below)
<b>Lubrication :</b>	Not required, if used select a medium aniline point lubricant (between 180°F to 210°F)
<b>Filtration :</b>	40 µ
<b>Temperature range :</b>	0°F to 120°F (-18°C to +50°C)
<b>Flow :</b>	1.0 C <sub>v</sub>

- Spare parts :
- Pressure regulator (less sandwich block) : PRA1A-J0AA (KNOB), PRA1A-C0AA (SLOTTED STEM), PRA1A-M0AA (SLOTTED STEM WITH LOCKNUT).
  - Gage : N-82016-01 (0-120 PSI perpendicular)  
 N-82016-02 (0-120 PSI parallel)  
 N-82016-03 (0-80 PSI perpendicular)  
 N-82016-04 (0-80 PSI parallel)  
 N-82016-05 (0-30 PSI perpendicular)  
 N-82016-06 (0-30 PSI parallel)

Regulating range options : PRA1A-XXXX

- Replace by B - 0 to 80 PSI
- Replace by C - 0 to 30 PSI
- Replace by D - 0 to 120 PSI on "14" end - 0 to 80 PSI on "12" end
- Replace by E - 0 to 120 PSI on "12" end - 0 to 80 PSI on "14" end
- Replace by F - 0 to 120 PSI on "14" end - 0 to 30 PSI on "12" end
- Replace by G - 0 to 120 PSI on "12" end - 0 to 30 PSI on "14" end
- Replace by H - 0 to 80 PSI on "14" end - 0 to 30 PSI on "12" end
- Replace by J - 0 to 80 PSI on "12" end - 0 to 30 PSI on "14" end

**DIMENSIONS**

Dimensions shown are metric (mm)

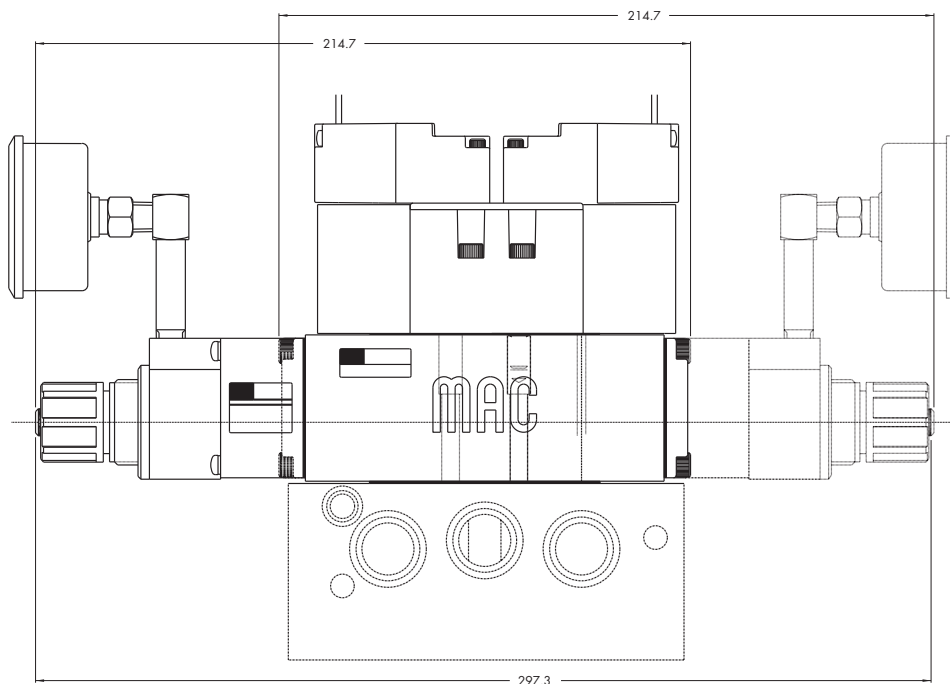

**Non plug-in sandwich pressure regulator with air pilot adjust**

**OPERATIONAL BENEFITS**

1. Easy mounting : saves on installation costs in comparison with inline regulators.
2. Allows to have compact, all-included units.
3. Large orifice provides high flow.
4. Various functions available.
5. Simple, reliable and solid design.



**PR37A**  
**PR42B**  
**PR46A**  
**PR47A**  
**PR48B**  
  
**PR92C**

**HOW TO ORDER**

INTERNAL PILOT

Gage	Single pressure Regulator 14 end Same regulated pressure to ports 2 and 4	Single pressure Regulator 12 end Same regulated pressure to ports 2 and 4	Dual pressure Regulator 14 end Regulated pressure to port 4 *	Dual pressure Regulator 12 end Regulated pressure to port 2 *	Dual pressure Dual regulator Two regulated pressures to ports 2 and 4 *
No gage	PRA1A-DAAA	PRA1A-DCAA	PRA1A-DBAA	PRA1A-DDAA	PRA1A-DEAA
Gage perpendicular to regulator(s)	PRA1A-DABA	PRA1A-DCBA	PRA1A-DBBA	PRA1A-DDBA	PRA1A-DECA
Gage parallel to regulator(s)	PRA1A-DADA	PRA1A-DCDA	PRA1A-DBDA	PRA1A-DDDA	PRA1A-DEEA

**PR93A**

**PRA01A**

**PRA02A**

EXTERNAL PILOT AND REMOTE AIR

Gage	Single pressure Regulator 14 end Same regulated pressure to ports 2 and 4	Single pressure Regulator 12 end Same regulated pressure to ports 2 and 4	Dual pressure Regulator 14 end Regulated pressure to port 4 *	Dual pressure Regulator 12 end Regulated pressure to port 2 *	Dual pressure Dual regulator Two regulated pressures to ports 2 and 4 *
No gage	PRA1A-EAAA	PRA1A-ECAA	PRA1A-EBAA	PRA1A-EDAA	PRA1A-EEAA
Gage perpendicular to regulator(s)	PRA1A-EABA	PRA1A-ECBA	PRA1A-EBBA	PRA1A-EDBA	PRA1A-EECA
Gage parallel to regulator(s)	PRA1A-EADA	PRA1A-ECDA	PRA1A-EBDA	PRA1A-EDDA	PRA1A-EEEA

**PRA1A**

**PRP1A**

**PRA2D**

**PRP2B**

**PRA3C**

**PRP3B**

\* - To be used with dual pressure valves.

Main valve body assembly must be external pilot model. Pilots are supplied internally from primary pressure in regulator block. Cannot field convert regulator block from Single Pressure to dual pressure. Body/Block to base mounting screw #35336.

**TECHNICAL DATA**

<b>Fluid :</b>	Compressed air, inert gases
<b>Pressure range :</b>	0 to 150 PSI
<b>Regulating range :</b>	0 to 120 PSI
<b>Lubrication :</b>	Not required, if used select a medium aniline point lubricant (between 180°F to 210°F)
<b>Filtration :</b>	40 µ
<b>Temperature range :</b>	0°F to 120°F (-18°C to +50°C)
<b>Flow :</b>	1.0 C <sub>v</sub>

Spare parts :

- Pressure regulator (less sandwich block) : PRA1A-F0AA.
- Gage : N-82016-01 (0-120 PSI perpendicular)  
N-82016-02 (0-120 PSI parallel)

**DIMENSIONS**

Dimensions shown are metric (mm)

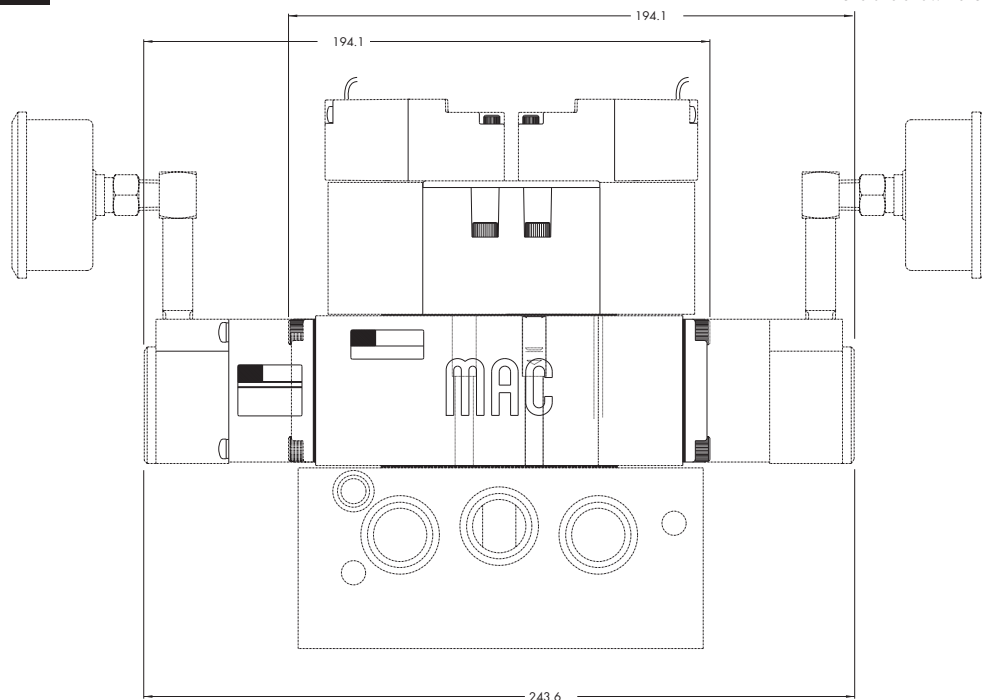

**Plug-in sandwich pressure regulator with manual adjust knob**

**OPERATIONAL BENEFITS**

1. Easy mounting: saves on installation costs in comparison with inline regulators.
2. Compact all-included units.
3. Large orifice provides high flow.
4. Various functions available.
5. Simple, reliable and solid design.



**PR37A**  
**PR42B**  
**PR46A**  
**PR47A**  
**PR48B**  
  
**PR92C**

**HOW TO ORDER**

REGULATORS FOR INTERNAL PILOT (CODED FOR KNOB ADJUSTMENT)

Gage	Single pressure Regulator 14 end Same regulated pressure to ports 2 and 4	Single pressure Regulator 12 end Same regulated pressure to ports 2 and 4	Dual pressure Regulator 14 end Regulated pressure to port 4 *	Dual pressure Regulator 12 end Regulated pressure to port 2 *	Dual pressure Dual regulator Two regulated pressures to ports 2 and 4 *
<b>Gage port only</b>	PRP1A-GAKA	PRP1A-GCKA	PRP1A-GBKA	PRP1A-GDKA	PRP1A-GEKA
<b>Gage perpendicular to manual operator</b>	PRP1A-GABA	PRP1A-GCBA	PRP1A-GBBA	PRP1A-GDBA	PRP1A-GECA
<b>Gage parallel to manual operator</b>	PRP1A-GADA	PRP1A-GCDA	PRP1A-GBDA	PRP1A-GDDA	PRP1A-GEEA

**PR93A**

**PRA01A**

**PRA02A**

REGULATORS FOR EXTERNAL PILOT AND REMOTE AIR (CODED FOR KNOB ADJUSTMENT)

Gage	Single pressure Regulator 14 end Same regulated pressure to ports 2 and 4	Single pressure Regulator 12 end Same regulated pressure to ports 2 and 4	Dual pressure Regulator 14 end Regulated pressure to port 4 *	Dual pressure Regulator 12 end Regulated pressure to port 2 *	Dual pressure Dual regulator Two regulated pressures to ports 2 and 4 *
<b>No gage</b>	PRP1A-HAKA	PRP1A-HCKA	PRP1A-HBKA	PRP1A-HDKA	PRP1A-HEKA
<b>Gage perpendicular to manual operator</b>	PRP1A-HABA	PRP1A-HCBA	PRP1A-HBBA	PRP1A-HDBA	PRP1A-HECA
<b>Gage parallel to manual operator</b>	PRP1A-HADA	PRP1A-HCDA	PRP1A-HBDA	PRP1A-HDDA	PRP1A-HEEA

**PRA1A**

**PRP1A**

**PRA2D**

**PRP2B**

**PRA3C**

**PRP3B**

\* For use with dual pressure valves.  
 Note: Regulating range for above models is 0 -120 PSI. For other ranges see technical data page.

**ADJUSTMENT OPTIONS**

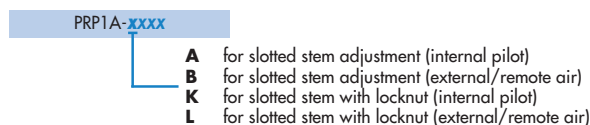

- Notes:
1. Valves used with above models must be external pilot models.
  2. Cannot field convert regulator block from single pressure to dual pressure.
  3. Cannot field convert from internal pilot to external pilot.
  4. Wired for double solenoid valves.

**TECHNICAL DATA**

<b>Fluid :</b>	Compressed air, inert gases
<b>Pressure range :</b>	0 to 150 PSI
<b>Regulating range :</b>	0 to 120 PSI (other ranges see below)
<b>Lubrication :</b>	Not required, if used select a medium aniline point lubricant (between 180°F to 210°F)
<b>Filtration :</b>	40 μ
<b>Temperature range :</b>	0°F to 120°F (-18°C to +50°C)
<b>Flow :</b>	1.1 C <sub>v</sub>

Spare parts :           • Pressure regulator (less sandwich block) : PRP1A-JOKA (knob), PRP1A-COKA (slotted stem)  
PRP1A-MOKA (slotted stem with locknut)

Regulating range options : PRP1A-XXXX

- Replace by B - 0 to 80 PSI
- Replace by C - 0 to 30 PSI
- Replace by D - 0 to 120 PSI on "14" end - 0 to 80 PSI on "12" end
- Replace by E - 0 to 120 PSI on "12" end - 0 to 80 PSI on "14" end
- Replace by F - 0 to 120 PSI on "14" end - 0 to 30 PSI on "12" end
- Replace by G - 0 to 120 PSI on "12" end - 0 to 30 PSI on "14" end
- Replace by H - 0 to 80 PSI on "14" end - 0 to 30 PSI on "12" end
- Replace by J - 0 to 80 PSI on "12" end - 0 to 30 PSI on "14" end

**DIMENSIONS**

Dimensions shown are metric (mm)

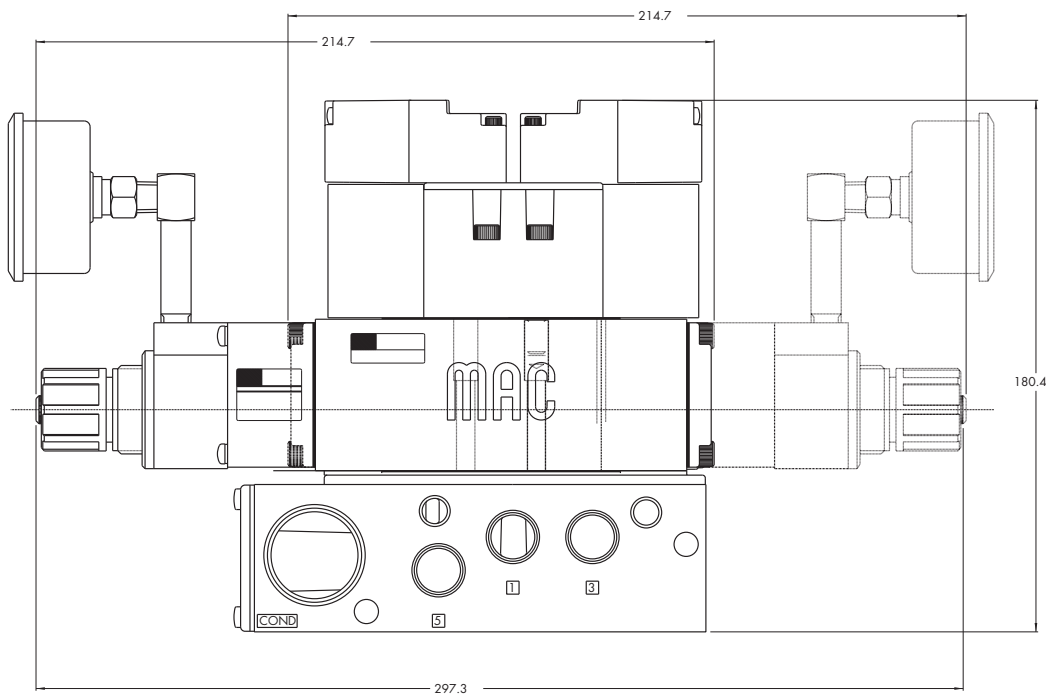

**Plug-in sandwich pressure regulator with air pilot adjust**

**OPERATIONAL BENEFITS**

1. Easy mounting: saves on installation costs in comparison with inline regulators.
2. Compact all-included units.
3. Large orifice provides high flow.
4. Various functions available.
5. Simple, reliable and solid design.



**PR37A**  
**PR42B**  
**PR46A**  
**PR47A**  
**PR48B**  
  
**PR92C**

**HOW TO ORDER**

REGULATORS FOR INTERNAL PILOT

Gage	Single pressure Regulator 14 end Same regulated pressure to ports 2 and 4	Single pressure Regulator 12 end Same regulated pressure to ports 2 and 4	Dual pressure Regulator 14 end Regulated pressure to port 4 *	Dual pressure Regulator 12 end Regulated pressure to port 2 *	Dual pressure Dual regulator Two regulated pressures to ports 2 and 4 *
<b>Gage port only</b>	PRP1A-DAKA	PRP1A-DCKA	PRP1A-DBKA	PRP1A-DDKA	PRP1A-DEKA
<b>Gage perpendicular to manual operator</b>	PRP1A-DABA	PRP1A-DCBA	PRP1A-DBBA	PRP1A-DDBA	PRP1A-DECA
<b>Gage parallel to manual operator</b>	PRP1A-DADA	PRP1A-DCDA	PRP1A-DBDA	PRP1A-DDDA	PRP1A-DEEA

**PR93A**  
  
**PRA01A**  
**PRA02A**

REGULATORS FOR EXTERNAL PILOT AND REMOTE AIR

Gage	Single pressure Regulator 14 end Same regulated pressure to ports 2 and 4	Single pressure Regulator 12 end Same regulated pressure to ports 2 and 4	Dual pressure Regulator 14 end Regulated pressure to port 4 *	Dual pressure Regulator 12 end Regulated pressure to port 2 *	Dual pressure Dual regulator Two regulated pressures to ports 2 and 4 *
<b>Gage port only</b>	PRP1A-EAKA	PRP1A-ECKA	PRP1A-EBKA	PRP1A-EDKA	PRP1A-EEKA
<b>Gage perpendicular to manual operator</b>	PRP1A-EABA	PRP1A-ECBA	PRP1A-EBBA	PRP1A-EDBA	PRP1A-EECA
<b>Gage parallel to manual operator</b>	PRP1A-EADA	PRP1A-ECDA	PRP1A-EBDA	PRP1A-EDDA	PRP1A-EEEA

**PRA1A**  
**PRP1A**

**PRA2D**  
  
**PRP2B**

\* - To be used with dual pressure valves.

Notes:

1. Valves used with above models must be external pilot models.
2. Cannot field convert regulator block from single pressure to dual pressure.
3. Cannot field convert from internal pilot to external pilot.
4. Wired for double solenoid valves.

**PRA3C**  
  
**PRP3B**



**TECHNICAL DATA**

<b>Fluid :</b>	Compressed air, inert gases
<b>Pressure range :</b>	0 to 150 PSI
<b>Regulating range :</b>	0 to 120 PSI
<b>Lubrication :</b>	Not required, if used select a medium aniline point lubricant (between 180°F to 210°F)
<b>Filtration :</b>	40 μ
<b>Temperature range :</b>	0°F to 120°F (-18°C to +50°C)
<b>Flow :</b>	1.1 C <sub>v</sub>

Spare parts :

- Pressure regulator (less sandwich block): PRP1A-FOKA
- Regulator block to base mounting tie rod: 19496

**DIMENSIONS**

Dimensions shown are metric (mm)

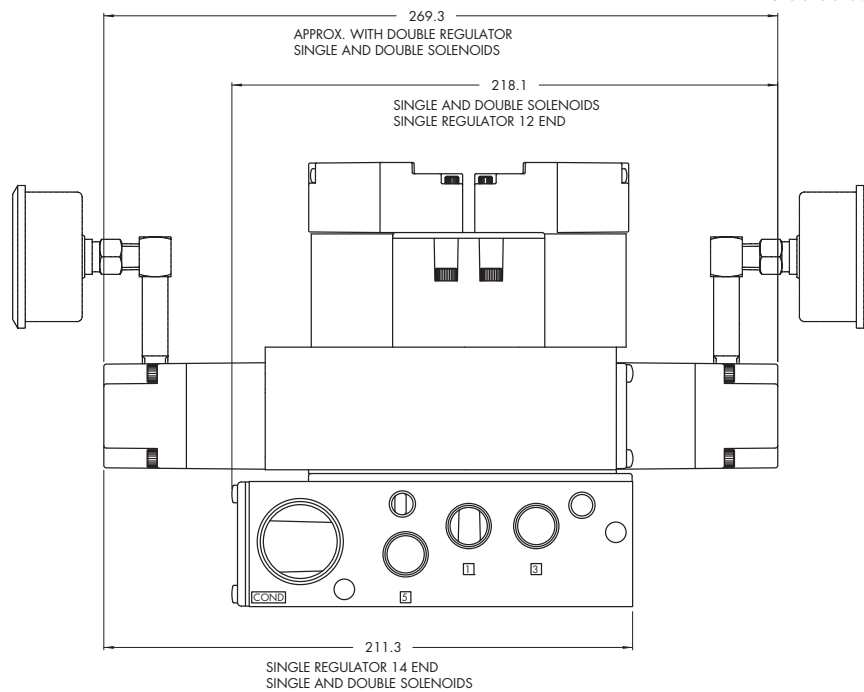

**Non plug-in sandwich pressure regulator with manual adjust knob**

**OPERATIONAL BENEFITS**

1. Easy mounting : saves on installation costs in comparison with inline regulators.
2. Allows to have compact, all-included units.
3. Large orifice provides high flow.
4. Various functions available.
5. Simple, reliable and solid design.



PR37A  
PR42B  
PR46A  
PR47A  
PR48B  
  
PR92C

**HOW TO ORDER**

INTERNAL PILOT

Gage	Single pressure Regulator 14 end Same regulated pressure to ports 2 and 4	Single pressure Regulator 12 end Same regulated pressure to ports 2 and 4	Dual pressure Regulator 14 end Regulated pressure to port 4 *	Dual pressure Regulator 12 end Regulated pressure to port 2 *	Dual pressure Dual regulator Two regulated pressures to ports 2 and 4 *
No gage	PRA2D-1AAA	PRA2D-1EAA	PRA2D-1BAA	PRA2D-1FAA	PRA2D-1JAA
Non-filled gage on regulator(s)	PRA2D-1ADA	PRA2D-1EDA	PRA2D-1BDA	PRA2D-1FDA	PRA2D-1JEA
Non-filled gage opposite to regulator	PRA2D-1CDA	PRA2D-1GDA	PRA2D-1DDA	PRA2D-1HDA	-----
Glycerine filled gage on regulator(s)	PRA2D-1ABA	PRA2D-1EBA	PRA2D-1BBA	PRA2D-1FBA	PRA2D-1JCA
Glycerine filled gage opposite to regulator	PRA2D-1CBA	PRA2D-1GBA	PRA2D-1DBA	PRA2D-1HBA	-----

PR93A

PRA01A

PRA02A

PRA1A

EXTERNAL PILOT AND REMOTE AIR

Gage	Single pressure Regulator 14 end Same regulated pressure to ports 2 and 4	Single pressure Regulator 12 end Same regulated pressure to ports 2 and 4	Dual pressure Regulator 14 end Regulated pressure to port 4 *	Dual pressure Regulator 12 end Regulated pressure to port 2 *	Dual pressure Dual regulator Two regulated pressures to ports 2 and 4 *
No gage	PRA2D-2AAA	PRA2D-2EAA	PRA2D-2BAA	PRA2D-2FAA	PRA2D-2JAA
Non-filled gage on regulator(s)	PRA2D-2ADA	PRA2D-2EDA	PRA2D-2BDA	PRA2D-2FDA	PRA2D-2JEA
Non-filled gage opposite to regulator	PRA2D-2CDA	PRA2D-2GDA	PRA2D-2DDA	PRA2D-2HDA	-----
Glycerine filled gage on regulator(s)	PRA2D-2ABA	PRA2D-2EBA	PRA2D-2BBA	PRA2D-2FBA	PRA2D-2JCA
Glycerine filled gage opposite to regulator	PRA2D-2CBA	PRA2D-2GBA	PRA2D-2DBA	PRA2D-2HBA	-----

PRP1A

**PRA2D**

PRP2B

PRA3C

PRP3B

\* - To be used with dual pressure valves.  
Note : regulating range for above models is 0-150 PSI.  
For other ranges see technical data page.

Main valve body assembly must be external pilot model. Pilots are supplied internally from primary pressure in regulator block. Cannot field convert regulator block from Single Pressure to dual pressure. Body/Block to base mounting screw #19177.

**ADJUSTMENT OPTIONS**

PRA2D-XXXX

- A** for slotted stem adjustment (internal pilot)
- B** for slotted stem adjustment (external pilot)
- D** for slotted stem with locknut (internal pilot)
- E** for slotted stem with locknut (external pilot)

**TECHNICAL DATA**

<b>Fluid :</b>	Compressed air, inert gases
<b>Pressure range :</b>	0 to 150 PSI
<b>Regulating range :</b>	0 to 150 PSI (other ranges see below)
<b>Lubrication :</b>	Not required, if used select a medium aniline point lubricant (between 180°F to 210°F)
<b>Filtration :</b>	40 µ
<b>Temperature range :</b>	0°F to 120°F (-18°C to +50°C)
<b>Flow :</b>	2.3 C <sub>v</sub>

Spare parts :  
 • Pressure regulator (less sandwich block) : PRA2D-30AA (KNOB), PRA2D-C0AA (SLOTTED STEM), PRA2D-F0AA (SLOTTED STEM WITH LOCKNUT).  
 • Gage : • Glycerine filled : N-62015-01  
 • Non filled : N-62016-01

Regulating range options : PRA2D-XXXA  

 Replace by B - 0 to 100 PSI  
 Replace by C - 0 to 45 PSI

**DIMENSIONS**

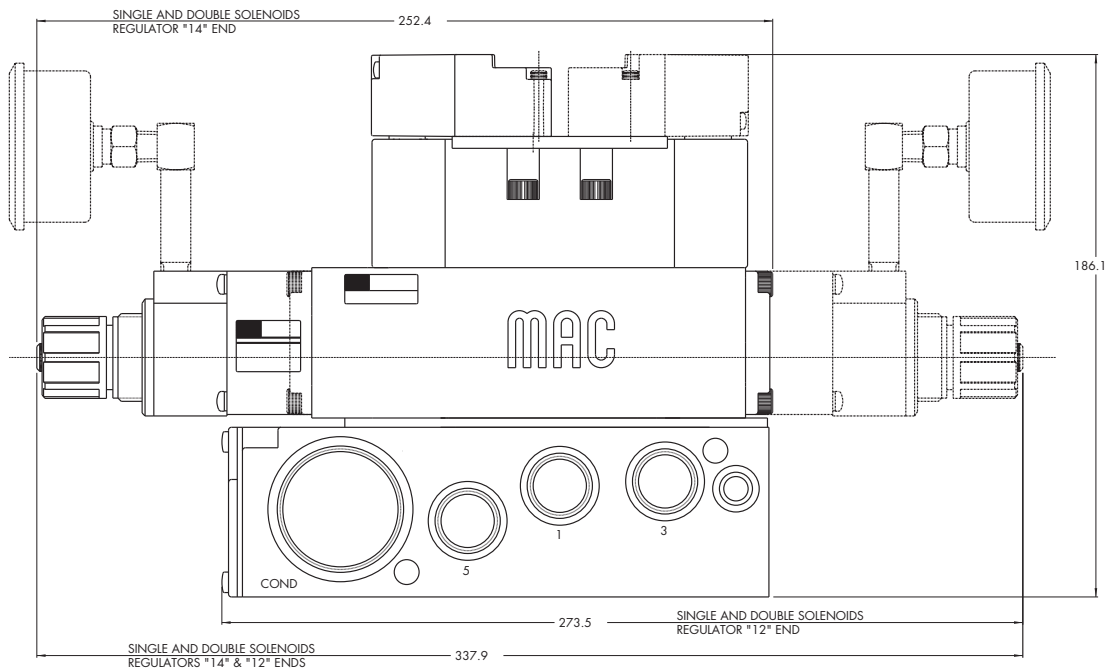
Dimensions shown are metric (mm)



**Non plug-in sandwich pressure regulator with air pilot adjust**

**OPERATIONAL BENEFITS**

1. Easy mounting : saves on installation costs in comparison with inline regulators.
2. Allows to have compact, all-included units.
3. Large orifice provides high flow.
4. Various functions available.
5. Simple, reliable and solid design.



PR37A  
PR42B  
PR46A  
PR47A  
PR48B  
  
PR92C

**HOW TO ORDER**

INTERNAL PILOT

Gage	Single pressure Regulator 14 end Same regulated pressure to ports 2 and 4	Single pressure Regulator 12 end Same regulated pressure to ports 2 and 4	Dual pressure Regulator 14 end Regulated pressure to port 4 *	Dual pressure Regulator 12 end Regulated pressure to port 2 *	Dual pressure Dual regulator Two regulated pressures to ports 2 and 4 *
No gage	PRA2D-4AAA	PRA2D-4EAA	PRA2D-4BAA	PRA2D-4FAA	PRA2D-4JAA
Non-filled gage on regulator(s)	PRA2D-4ADA	PRA2D-4EDA	PRA2D-4BDA	PRA2D-4FDA	PRA2D-4JEA
Non-filled gage opposite to regulator	PRA2D-4CDA	PRA2D-4GDA	PRA2D-4DDA	PRA2D-4HDA	-----
Glycerine filled gage on regulator(s)	PRA2D-4ABA	PRA2D-4EBA	PRA2D-4BBA	PRA2D-4FBA	PRA2D-4JCA
Glycerine filled gage opposite to regulator	PRA2D-4CBA	PRA2D-4GBA	PRA2D-4DBA	PRA2D-4HBA	-----

PR93A

PRA01A

PRA02A

PRA1A

EXTERNAL PILOT AND REMOTE AIR

Gage	Single pressure Regulator 14 end Same regulated pressure to ports 2 and 4	Single pressure Regulator 12 end Same regulated pressure to ports 2 and 4	Dual pressure Regulator 14 end Regulated pressure to port 4 *	Dual pressure Regulator 12 end Regulated pressure to port 2 *	Dual pressure Dual regulator Two regulated pressures to ports 2 and 4 *
No gage	PRA2D-5AAA	PRA2D-5EAA	PRA2D-5BAA	PRA2D-5FAA	PRA2D-5JAA
Non-filled gage on regulator(s)	PRA2D-5ADA	PRA2D-5EDA	PRA2D-5BDA	PRA2D-5FDA	PRA2D-5JEA
Non-filled gage opposite to regulator	PRA2D-5CDA	PRA2D-5GDA	PRA2D-5DDA	PRA2D-5HDA	-----
Glycerine filled gage on regulator(s)	PRA2D-5ABA	PRA2D-5EBA	PRA2D-5BBA	PRA2D-5FBA	PRA2D-5JCA
Glycerine filled gage opposite to regulator	PRA2D-5CBA	PRA2D-5GBA	PRA2D-5DBA	PRA2D-5HBA	-----

PRP1A

PRA2D

PRP2B

PRA3C

PRP3B

\* - To be used with dual pressure valves.

Main valve body assembly must be external pilot model. Pilots are supplied internally from primary pressure in regulator block. Cannot field convert regulator block from Single Pressure to dual pressure. Body/Block to base mounting screw #19177.

**TECHNICAL DATA**

<b>Fluid :</b>	Compressed air, inert gases
<b>Pressure range :</b>	0 to 150 PSI
<b>Regulating range :</b>	0 to 150 PSI
<b>Lubrication :</b>	Not required, if used select a medium aniline point lubricant (between 180°F to 210°F)
<b>Filtration :</b>	40 μ
<b>Temperature range :</b>	0°F to 120°F (-18°C to +50°C)
<b>Flow :</b>	2.3 C <sub>v</sub>

Spare parts :

- Pressure regulator (less sandwich block) : PRA2D-60AA.
- Gage : • Glycerine filled : N-62015-01
- Non filled : N-62016-01

**DIMENSIONS**

Dimensions shown are metric (mm)

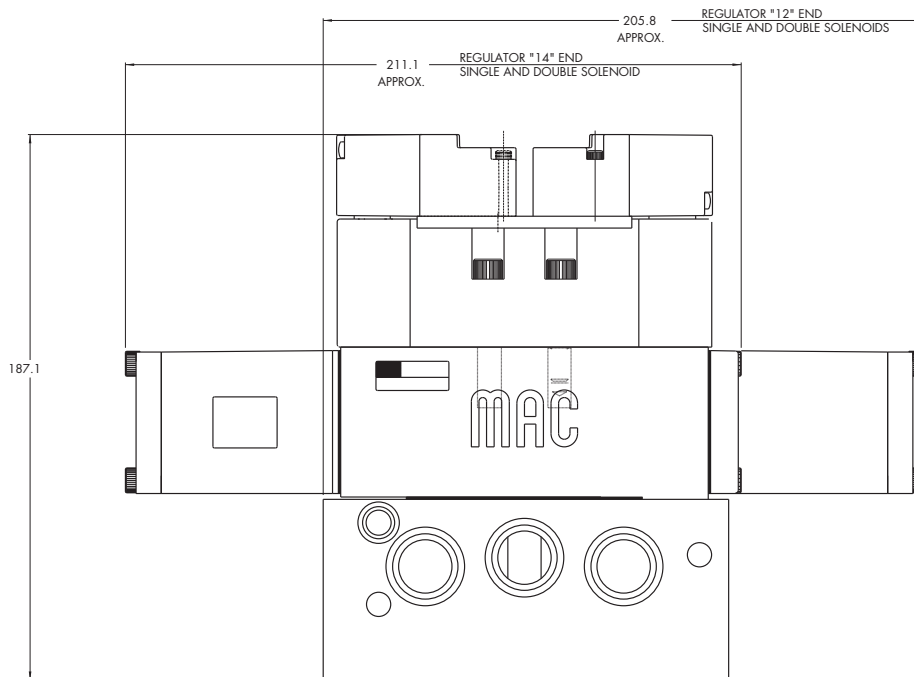

**Plug-in sandwich pressure regulator with manual adjust knob**

**OPERATIONAL BENEFITS**

1. Easy mounting: saves on installation costs in comparison with inline regulators.
2. Compact all-included units.
3. Large orifice provides high flow.
4. Various functions available.
5. Simple, reliable and solid design.



**PR37A**  
**PR42B**  
**PR46A**  
**PR47A**  
**PR48B**  
  
**PR92C**

**HOW TO ORDER**

REGULATORS FOR INTERNAL PILOT (CODED FOR KNOB ADJUSTMENT)

Gage	Single pressure Regulator 14 end Same regulated pressure to ports 2 and 4	Single pressure Regulator 12 end Same regulated pressure to ports 2 and 4	Dual pressure Regulator 14 end Regulated pressure to port 4 *	Dual pressure Regulator 12 end Regulated pressure to port 2 *	Dual pressure Dual regulator Two regulated pressures to ports 2 and 4 *
<b>No gage</b>	PRP2B-AAAA	PRP2B-AEAA	PRP2B-ABAA	PRP2B-AFAA	PRP2B-AJAA
<b>Glycerine gage</b>	PRP2B-AABA	PRP2B-AEBA	PRP2B-ABBA	PRP2B-AFBA	PRP2B-AJCA
<b>Non-filled gage</b>	PRP2B-AADA	PRP2B-AEDA	PRP2B-ABDA	PRP2B-AFDA	PRP2B-AJEA

**PR93A**  
  
**PRA01A**  
  
**PRA02A**

REGULATORS FOR EXTERNAL PILOT AND REMOTE AIR (CODED FOR KNOB ADJUSTMENT)

Gage	Single pressure Regulator 14 end Same regulated pressure to ports 2 and 4	Single pressure Regulator 12 end Same regulated pressure to ports 2 and 4	Dual pressure Regulator 14 end Regulated pressure to port 4 *	Dual pressure Regulator 12 end Regulated pressure to port 2 *	Dual pressure Dual regulator Two regulated pressures to ports 2 and 4 *
<b>No gage</b>	PRP2B-BAAA	PRP2B-BEAA	PRP2B-BBAA	PRP2B-BFAA	PRP2B-BJAA
<b>Glycerine gage</b>	PRP2B-BABA	PRP2B-BEBA	PRP2B-BBBA	PRP2B-BFBA	PRP2B-BJCA
<b>Non-filled gage</b>	PRP2B-BADA	PRP2B-BEDA	PRP2B-BBDA	PRP2B-BFDA	PRP2B-BJEA

**PRA1A**  
  
**PRP1A**  
  
**PRA2D**

**PRP2B**

\* For use with dual pressure valves.  
Note: Regulating range for above models is 0-150 PSI. For other ranges, see technical data page.

**ADJUSTMENT OPTIONS**

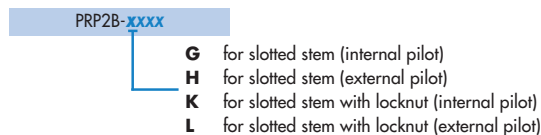

- Notes:
1. Valves used with above models must be external pilot models.
  2. Cannot field convert regulator block from single pressure to dual pressure.
  3. Cannot field convert from internal pilot to external pilot.
  4. Wired for double solenoid valves.

**PRA3C**  
  
**PRP3B**

**TECHNICAL DATA**

<b>Fluid :</b>	Compressed air, inert gases
<b>Pressure range :</b>	0 to 150 PSI
<b>Regulating range :</b>	0 to 150 PSI (other ranges see below)
<b>Lubrication :</b>	Not required, if used select a medium aniline point lubricant (between 180°F to 210°F)
<b>Filtration :</b>	40 μ
<b>Temperature range :</b>	0°F to 120°F (-18°C to +50°C)
<b>Flow :</b>	3.1 C <sub>v</sub>

Spare parts :

- Pressure regulator (less sandwich block) : PRP2B-COAA (knob), PRP2B-JOAA (slotted stem), PRP2B-MOAA (slotted stem with locknut)
- Regulator block to base mounting screw: 19177
- Regulating range option: PRP2B-xxxA

Replace by B for 0 to 100 PSI  
Replace by C for 0 to 45 PSI

**DIMENSIONS**

Dimensions shown are metric (mm)

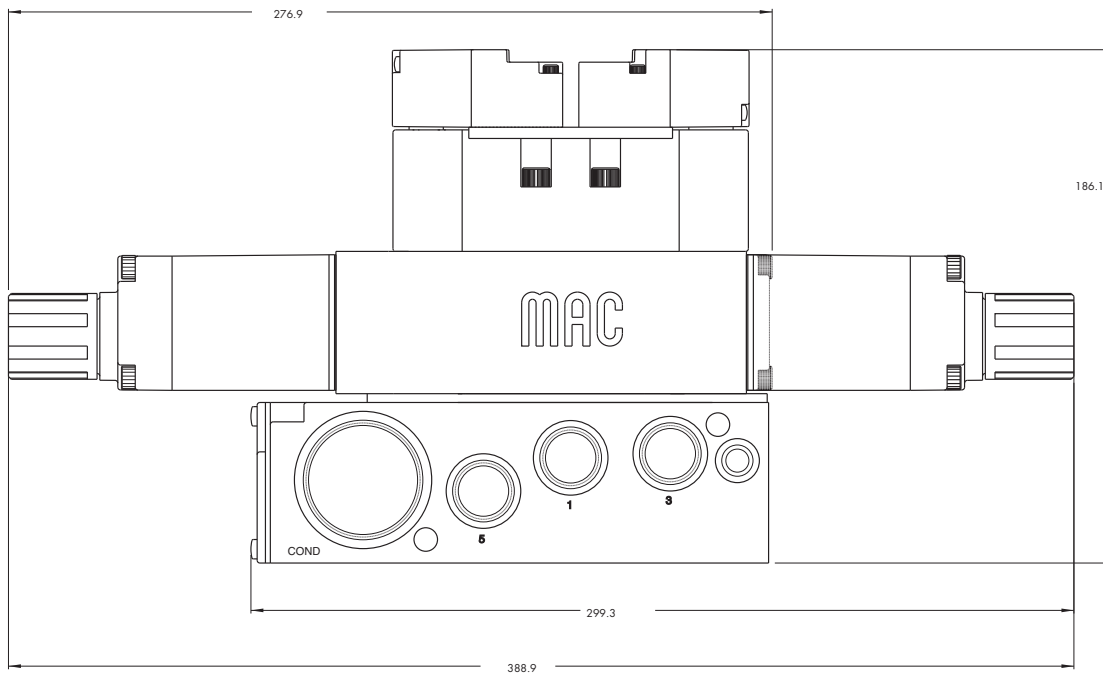

**Plug-in sandwich pressure regulator with air pilot adjust**

**OPERATIONAL BENEFITS**

1. Easy mounting: saves on installation costs in comparison with inline regulators.
2. Compact all-included units.
3. Large orifice provides high flow.
4. Various functions available.
5. Simple, reliable and solid design.



**PR37A**  
**PR42B**  
**PR46A**  
**PR47A**  
**PR48B**  
  
**PR92C**

**HOW TO ORDER**

REGULATORS FOR INTERNAL PILOT

Gage	Single pressure Regulator 14 end Same regulated pressure to ports 2 and 4	Single pressure Regulator 12 end Same regulated pressure to ports 2 and 4	Dual pressure Regulator 14 end Regulated pressure to port 4 *	Dual pressure Regulator 12 end Regulated pressure to port 2 *	Dual pressure Dual regulator Two regulated pressures to ports 2 and 4 *
<b>No gage</b>	PRP2B-DAAA	PRP2B-DEAA	PRP2B-DBAA	PRP2B-DFAA	PRP2B-DJAA
<b>Glycerine gage</b>	PRP2B-DABA	PRP2B-DEBA	PRP2B-DBBA	PRP2B-DFBA	PRP2B-DJCA
<b>Non-filled gage</b>	PRP2B-DADA	PRP2B-DEDA	PRP2B-DBDA	PRP2B-DFDA	PRP2B-DJEA

**PR93A**  
  
**PRA01A**  
**PRA02A**

REGULATORS FOR EXTERNAL PILOT AND REMOTE AIR

Gage	Single pressure Regulator 14 end Same regulated pressure to ports 2 and 4	Single pressure Regulator 12 end Same regulated pressure to ports 2 and 4	Dual pressure Regulator 14 end Regulated pressure to port 4 *	Dual pressure Regulator 12 end Regulated pressure to port 2 *	Dual pressure Dual regulator Two regulated pressures to ports 2 and 4 *
<b>No gage</b>	PRP2B-EAAA	PRP2B-EEAA	PRP2B-EBAA	PRP2B-EFAA	PRP2B-EJAA
<b>Glycerine gage</b>	PRP2B-EABA	PRP2B-EEBA	PRP2B-EBBA	PRP2B-EFBA	PRP2B-EJCA
<b>Non-filled gage</b>	PRP2B-EADA	PRP2B-EEDA	PRP2B-EBDA	PRP2B-EFDA	PRP2B-EJEA

**PRA1A**  
**PRP1A**  
  
**PRA2D**

\* - To be used with dual pressure valves.

Notes:

1. Valves used with above models must be external pilot models.
2. Cannot field convert regulator block from single pressure to dual pressure.
3. Cannot field convert from internal pilot to external pilot.
4. Wired for double solenoid valves.

**PRP2B**  
  
**PRA3C**  
  
**PRP3B**



**TECHNICAL DATA**

<b>Fluid :</b>	Compressed air, inert gases
<b>Pressure range :</b>	0 to 150 PSI
<b>Regulating range :</b>	0 to 150 PSI
<b>Lubrication :</b>	Not required, if used select a medium aniline point lubricant (between 180°F to 210°F)
<b>Filtration :</b>	40 μ
<b>Temperature range :</b>	0°F to 120°F (-18°C to +50°C)
<b>Flow :</b>	3.1 C <sub>v</sub>

Spare parts :

- Pressure regulator (less sandwich block): PRP2B-F0AA
- Body/block to base mounting screw: 19177

**DIMENSIONS**

Dimensions shown are metric (mm)

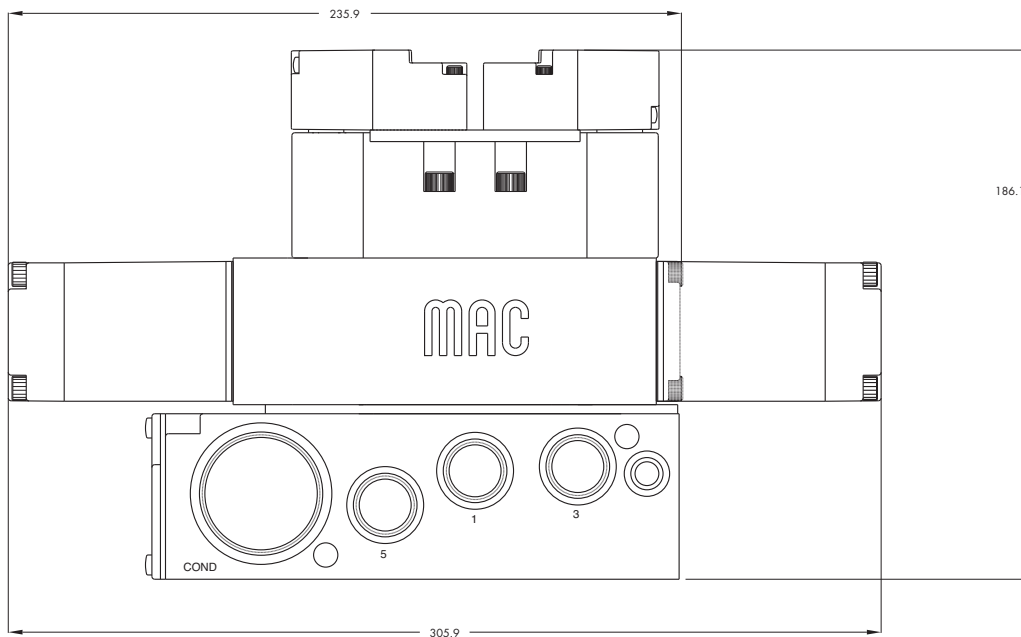

**Non plug-in sandwich pressure regulator with manual adjust knob**

**OPERATIONAL BENEFITS**

1. Easy mounting : saves on installation costs in comparison with inline regulators.
2. Allows to have compact, all-included units.
3. Large orifice provides high flow.
4. Various functions available.
5. Simple, reliable and solid design.



PR37A  
PR42B  
PR46A  
PR47A  
PR48B  
  
PR92C

**HOW TO ORDER**

INTERNAL PILOT

Gage	Single pressure Regulator 14 end Same regulated pressure to ports 2 and 4	Single pressure Regulator 12 end Same regulated pressure to ports 2 and 4	Dual pressure Regulator 14 end Regulated pressure to port 4 *	Dual pressure Regulator 12 end Regulated pressure to port 2 *	Dual pressure Dual regulator Two regulated pressures to ports 2 and 4 *
No gage	PRA3C-1AAA	PRA3C-1EAA	PRA3C-1BAA	PRA3C-1FAA	PRA3C-1JAA
Non-filled gage on regulator(s)	PRA3C-1ADA	PRA3C-1EDA	PRA3C-1BDA	PRA3C-1FDA	PRA3C-1JEA
Non-filled gage opposite to regulator	PRA3C-1CDA	PRA3C-1GDA	PRA3C-1DDA	PRA3C-1HDA	-----
Glycerine filled gage on regulator(s)	PRA3C-1ABA	PRA3C-1EBA	PRA3C-1BBA	PRA3C-1FBA	PRA3C-1JCA
Glycerine filled gage opposite to regulator	PRA3C-1CBA	PRA3C-1GBA	PRA3C-1DBA	PRA3C-1HBA	-----

PR93A  
  
PRA01A  
PRA02A  
  
PRA1A

EXTERNAL PILOT AND REMOTE AIR

Gage	Single pressure Regulator 14 end Same regulated pressure to ports 2 and 4	Single pressure Regulator 12 end Same regulated pressure to ports 2 and 4	Dual pressure Regulator 14 end Regulated pressure to port 4 *	Dual pressure Regulator 12 end Regulated pressure to port 2 *	Dual pressure Dual regulator Two regulated pressures to ports 2 and 4 *
No gage	PRA3C-2AAA	PRA3C-2EAA	PRA3C-2BAA	PRA3C-2FAA	PRA3C-2JAA
Non-filled gage on regulator(s)	PRA3C-2ADA	PRA3C-2EDA	PRA3C-2BDA	PRA3C-2FDA	PRA3C-2JEA
Non-filled gage opposite to regulator	PRA3C-2CDA	PRA3C-2GDA	PRA3C-2DDA	PRA3C-2HDA	-----
Glycerine filled gage on regulator(s)	PRA3C-2ABA	PRA3C-2EBA	PRA3C-2BBA	PRA3C-2FBA	PRA3C-2JCA
Glycerine filled gage opposite to regulator	PRA3C-2CBA	PRA3C-2GBA	PRA3C-2DBA	PRA3C-2HBA	-----

PRP1A  
  
PRA2D  
  
PRP2B

\* - To be used with dual pressure valves.  
Note : regulating range for above models is 0-150 PSI.  
For other ranges see technical data page.

Main valve body assembly must be external pilot model. Pilots are supplied internally from primary pressure in regulator block. Cannot field convert regulator block from Single Pressure to dual pressure. Body/Block to base mounting screw #35418.

**ADJUSTMENT OPTIONS**

PRA3C-xxxx

- A for slotted stem adjustment (internal pilot)
- B for slotted stem adjustment (external pilot)
- D for slotted stem with locknut (internal pilot)
- E for slotted stem with locknut (external pilot)

**PRA3C**  
  
PRP3B

**TECHNICAL DATA**

<b>Fluid :</b>	Compressed air, inert gases
<b>Pressure range :</b>	0 to 150 PSI
<b>Regulating range :</b>	0 to 150 PSI (other ranges see below)
<b>Lubrication :</b>	Not required, if used select a medium aniline point lubricant (between 180°F to 210°F)
<b>Filtration :</b>	40 μ
<b>Temperature range :</b>	0°F to 120°F (-18°C to +50°C)
<b>Flow :</b>	5.4 C <sub>v</sub>

- Spare parts :
- Pressure regulator (less sandwich block) : PRA3C-30AA (KNOB), PRA3C-C0AA (SLOTTED STEM), PRA3C-F0AA (SLOTTED STEM WITH LOCKNUT).
  - Gage : • Glycerine filled : N-62015-01  
• Non filled : N-62016-01

Regulating range options : PRA3C-XXXX

Replace by B	- 0 to 100 PSI
Replace by C	- 0 to 45 PSI

**DIMENSIONS**

Dimensions shown are metric (mm)

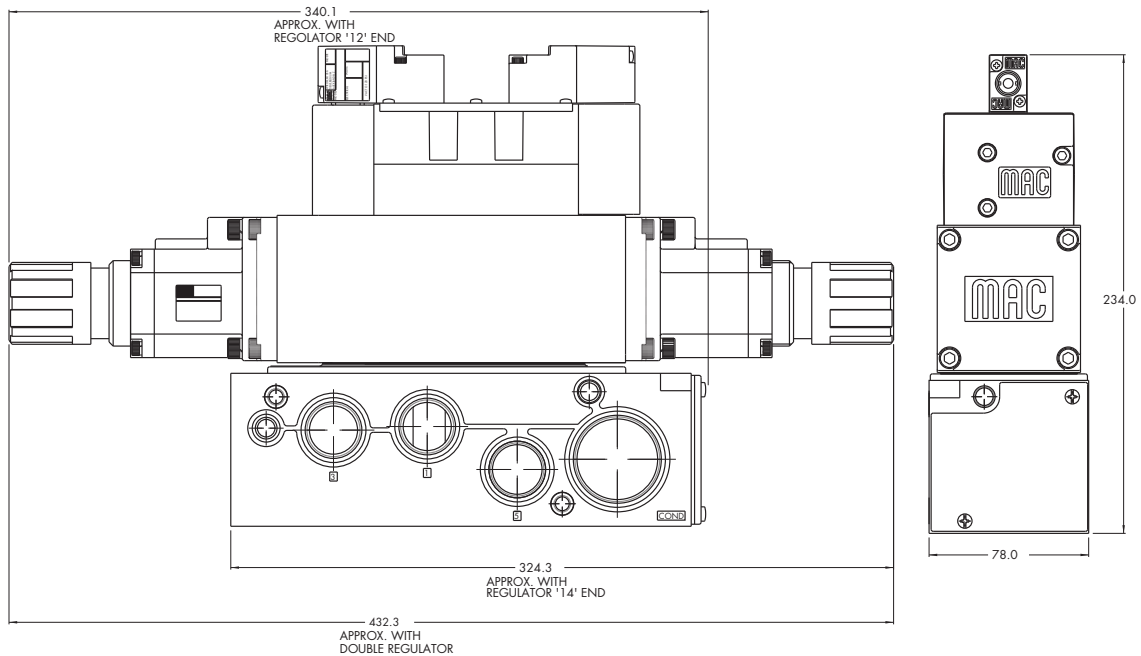

**Non plug-in sandwich pressure regulator with air pilot adjust**

**OPERATIONAL BENEFITS**

1. Easy mounting : saves on installation costs in comparison with inline regulators.
2. Allows to have compact, all-included units.
3. Large orifice provides high flow.
4. Various functions available.
5. Simple, reliable and solid design.



PR37A  
PR42B  
PR46A  
PR47A  
PR48B  
  
PR92C

**HOW TO ORDER**

INTERNAL PILOT

Gage	Single pressure Regulator 14 end Same regulated pressure to ports 2 and 4	Single pressure Regulator 12 end Same regulated pressure to ports 2 and 4	Dual pressure Regulator 14 end Regulated pressure to port 4	Dual pressure Regulator 12 end Regulated pressure to port 2	Dual pressure Dual regulator Two regulated pressures to ports 2 and 4
No gage	PRA3C-4AAA	PRA3C-4EAA	PRA3C-4BAA	PRA3C-4FAA	PRA3C-4JAA
Non-filled gage on regulator(s)	PRA3C-4ADA	PRA3C-4EDA	PRA3C-4BDA	PRA3C-4FDA	PRA3C-4JEA
Non-filled gage opposite to regulator	PRA3C-4CDA	PRA3C-4GDA	PRA3C-4DDA	PRA3C-4HDA	-----
Glycerine filled gage on regulator(s)	PRA3C-4ABA	PRA3C-4EBA	PRA3C-4BBA	PRA3C-4FBA	PRA3C-4JCA
Glycerine filled gage opposite to regulator	PRA3C-4CBA	PRA3C-4GBA	PRA3C-4DBA	PRA3C-4HBA	-----

PR93A

PRA01A

PRA02A

PRA1A

EXTERNAL PILOT AND REMOTE AIR

Gage	Single pressure Regulator 14 end Same regulated pressure to ports 2 and 4	Single pressure Regulator 12 end Same regulated pressure to ports 2 and 4	Dual pressure Regulator 14 end Regulated pressure to port 4	Dual pressure Regulator 12 end Regulated pressure to port 2	Dual pressure Dual regulator Two regulated pressures to ports 2 and 4
No gage	PRA3C-5AAA	PRA3C-5EAA	PRA3C-5BAA	PRA3C-5FAA	PRA3C-5JAA
Non-filled gage on regulator(s)	PRA3C-5ADA	PRA3C-5EDA	PRA3C-5BDA	PRA3C-5FDA	PRA3C-5JEA
Non-filled gage opposite to regulator	PRA3C-5CDA	PRA3C-5GDA	PRA3C-5DDA	PRA3C-5HDA	-----
Glycerine filled gage on regulator(s)	PRA3C-5ABA	PRA3C-5EBA	PRA3C-5BBA	PRA3C-5FBA	PRA3C-5JCA
Glycerine filled gage opposite to regulator	PRA3C-5CBA	PRA3C-5GBA	PRA3C-5DBA	PRA3C-5HBA	-----

PRP1A

PRA2D

PRP2B

\* - To be used with dual pressure valves.

Main valve body assembly must be external pilot model. Pilots are supplied internally from primary pressure in regulator block. Cannot field convert regulator block from Single Pressure to dual pressure. Body/Block to base mounting screw #35418.

**PRA3C**

PRP3B

**TECHNICAL DATA**

<b>Fluid :</b>	Compressed air, inert gases
<b>Pressure range :</b>	0 to 150 PSI
<b>Regulating range :</b>	0 to 150 PSI
<b>Lubrication :</b>	Not required, if used select a medium aniline point lubricant (between 180°F to 210°F)
<b>Filtration :</b>	40 µ
<b>Temperature range :</b>	0°F to 120°F (-18°C to +50°C)
<b>Flow :</b>	5.4 C <sub>v</sub>

Spare parts :

- Pressure regulator (less sandwich block) : PRA3C-60AA.
- Gage : • Glycerine filled : N-62015-01
- Non filled : N-62016-01

**DIMENSIONS**

Dimensions shown are metric (mm)

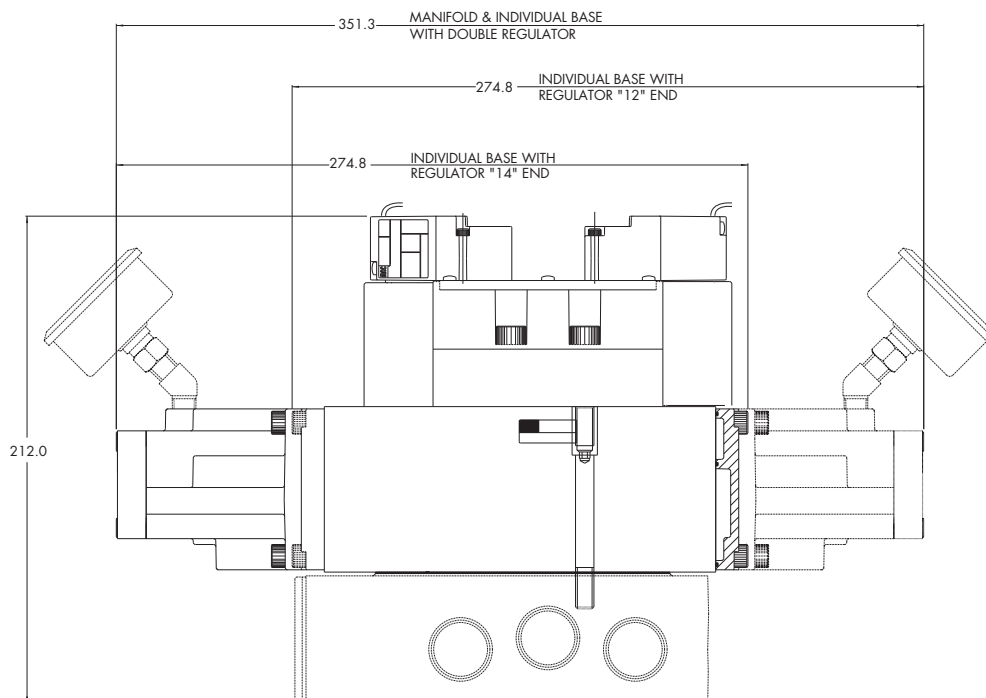

**Plug-in sandwich pressure regulator with manual adjust knob**

**OPERATIONAL BENEFITS**

1. Easy mounting: saves on installation costs in comparison with inline regulators.
2. Compact all-included units.
3. Large orifice provides high flow.
4. Various functions available.
5. Simple, reliable and solid design.



**PR37A**  
**PR42B**  
**PR46A**  
**PR47A**  
**PR48B**  
**PR92C**

**HOW TO ORDER**

REGULATORS FOR INTERNAL PILOT (CODED FOR KNOB ADJUSTMENT)

Gage	Single pressure Regulator 14 end Same regulated pressure to ports 2 and 4	Single pressure Regulator 12 end Same regulated pressure to ports 2 and 4	Dual pressure Regulator 14 end Regulated pressure to port 4 *	Dual pressure Regulator 12 end Regulated pressure to port 2 *	Dual pressure Dual regulator Two regulated pressures to ports 2 and 4 *
<b>No gage</b>	PRP3B-AAAA	PRP3B-AEAA	PRP3B-ABAA	PRP3B-AFAA	PRP3B-AJAA
<b>Glycerine gage</b>	PRP3B-AABA	PRP3B-AEBA	PRP3B-ABBA	PRP3B-AFBA	PRP3B-AJCA
<b>Non-filled gage</b>	PRP3B-AADA	PRP3B-AEDA	PRP3B-ABDA	PRP3B-AFDA	PRP3B-AJEA

**PR93A**  
**PRA01A**  
**PRA02A**

REGULATORS FOR EXTERNAL PILOT AND REMOTE AIR (CODED FOR KNOB ADJUSTMENT)

Gage	Single pressure Regulator 14 end Same regulated pressure to ports 2 and 4	Single pressure Regulator 12 end Same regulated pressure to ports 2 and 4	Dual pressure Regulator 14 end Regulated pressure to port 4 *	Dual pressure Regulator 12 end Regulated pressure to port 2 *	Dual pressure Dual regulator Two regulated pressures to ports 2 and 4 *
<b>No gage</b>	PRP3B-BAAA	PRP3B-BEAA	PRP3B-BBAA	PRP3B-BFAA	PRP3B-BJAA
<b>Glycerine gage</b>	PRP3B-BABA	PRP3B-BEBA	PRP3B-BBBA	PRP3B-BFBA	PRP3B-BJCA
<b>Non-filled gage</b>	PRP3B-BADA	PRP3B-BEDA	PRP3B-BBDA	PRP3B-BFDA	PRP3B-BJEA

**PRA1A**  
**PRP1A**  
**PRA2D**  
**PRP2B**

\* For use with dual pressure valves.

**ADJUSTMENT OPTIONS**

PRP3B-xxxx	<b>G</b> for slotted stem (internal pilot)
	<b>H</b> for slotted stem (external pilot)
	<b>K</b> for slotted stem with locknut (internal pilot)
	<b>L</b> for slotted stem with locknut (external pilot)

Notes:

1. Regulating range for above models is 0-150 PSI. For other ranges, see technical data page.
2. Valves used with above models must be external pilot models.
3. Cannot field convert regulator block from single pressure to dual pressure.
4. Cannot field convert from internal pilot to external pilot.
5. Wired for double solenoid valves.

**PRA3C**

**PRP3B**

**TECHNICAL DATA**

<b>Fluid :</b>	Compressed air, inert gases
<b>Pressure range :</b>	0 to 150 PSI
<b>Regulating range :</b>	0 to 150 PSI (other ranges see below)
<b>Lubrication :</b>	Not required, if used select a medium aniline point lubricant (between 180°F to 210°F)
<b>Filtration :</b>	40 μ
<b>Temperature range :</b>	0°F to 120°F (-18°C to +50°C)
<b>Flow :</b>	5.4 C <sub>v</sub>

Spare parts :

- Pressure regulator (less sandwich block): PRP3B-COAA (knob), PRP3B-JOAA (slotted stem), PRP3B-MOAA (slotted stem with locknut)
- Regulating block to base mounting screw: 19457
- Regulating range options: PRP3B-xxx<sup>A</sup>

 Replace by B for 0 to 100 PSI  
 Replace by C for 0 to 45 PSI

**DIMENSIONS**

Dimensions shown are metric (mm)

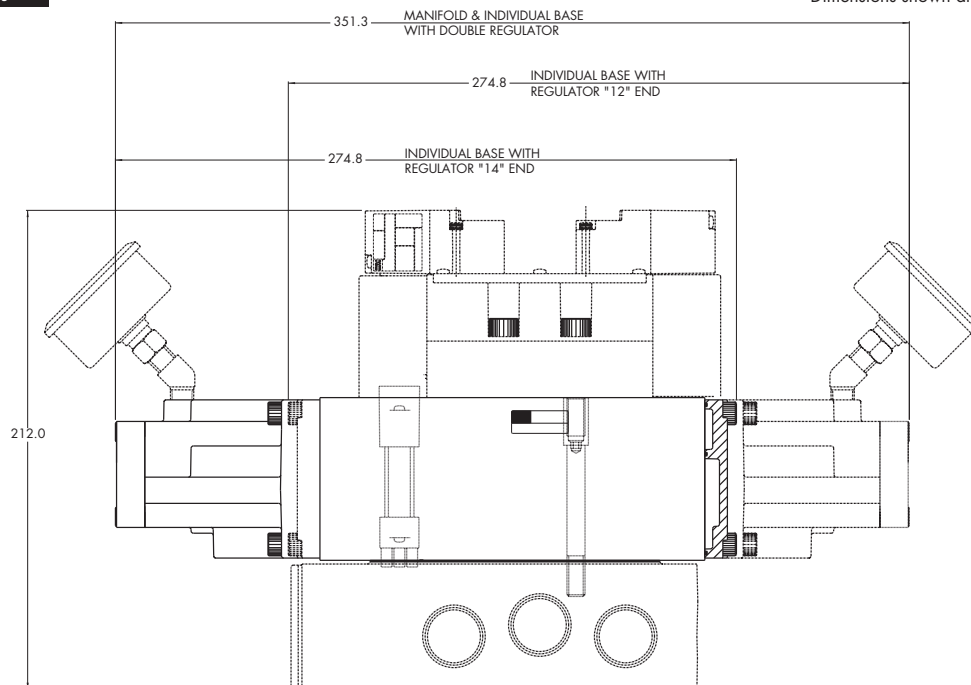

**Plug-in sandwich pressure regulator with air pilot adjust**

**OPERATIONAL BENEFITS**

1. Easy mounting: saves on installation costs in comparison with inline regulators.
2. Compact all-included units.
3. Large orifice provides high flow.
4. Various functions available.
5. Simple, reliable and solid design.



**PR37A**  
**PR42B**  
**PR46A**  
**PR47A**  
**PR48B**  
  
**PR92C**

**HOW TO ORDER**

REGULATORS FOR INTERNAL PILOT

Gage	Single pressure Regulator 14 end Same regulated pressure to ports 2 and 4	Single pressure Regulator 12 end Same regulated pressure to ports 2 and 4	Dual pressure Regulator 14 end Regulated pressure to port 4 *	Dual pressure Regulator 12 end Regulated pressure to port 2 *	Dual pressure Dual regulator Two regulated pressures to ports 2 and 4 *
<b>No gage</b>	PRP3B-DAAA	PRP3B-DEAA	PRP3B-DBAA	PRP3B-DFAA	PRP3B-DJAA
<b>Glycerine gage</b>	PRP3B-DABA	PRP3B-DEBA	PRP3B-DBBA	PRP3B-DFBA	PRP3B-DJCA
<b>Non-filled gage</b>	PRP3B-DADA	PRP3B-DEDA	PRP3B-DBDA	PRP3B-DFDA	PRP3B-DJEA

**PR93A**  
  
**PRA01A**  
**PRA02A**

REGULATORS FOR EXTERNAL PILOT AND REMOTE AIR

Gage	Single pressure Regulator 14 end Same regulated pressure to ports 2 and 4	Single pressure Regulator 12 end Same regulated pressure to ports 2 and 4	Dual pressure Regulator 14 end Regulated pressure to port 4 *	Dual pressure Regulator 12 end Regulated pressure to port 2 *	Dual pressure Dual regulator Two regulated pressures to ports 2 and 4 *
<b>No gage</b>	PRP3B-EAAA	PRP3B-EEAA	PRP3B-EBAA	PRP3B-EFAA	PRP3B-EJAA
<b>Glycerine gage</b>	PRP3B-EABA	PRP3B-EEBA	PRP3B-EBBA	PRP3B-EFBA	PRP3B-EJCA
<b>Non-filled gage</b>	PRP3B-EADA	PRP3B-EEDA	PRP3B-EBDA	PRP3B-EFDA	PRP3B-EJEA

**PRA1A**  
**PRP1A**  
  
**PRA2D**  
  
**PRP2B**

\* - To be used with dual pressure valves.

Notes:

1. Valves used with above models must be external pilot models.
2. Cannot field convert regulator block from single pressure to dual pressure.
3. Cannot field convert from internal pilot to external pilot.
4. Wired for double solenoid valves.

**PRA3C**

**PRP3B**



**TECHNICAL DATA**

<b>Fluid :</b>	Compressed air, inert gases
<b>Pressure range :</b>	0 to 150 PSI
<b>Regulating range :</b>	0 to 150 PSI
<b>Lubrication :</b>	Not required, if used select a medium aniline point lubricant (between 180°F to 210°F)
<b>Filtration :</b>	40 μ
<b>Temperature range :</b>	0°F to 120°F (-18°C to +50°C)
<b>Flow :</b>	5.4 C <sub>v</sub>

Spare parts :

- Pressure regulator (less sandwich block): PRP3B-F0AA
- Regulator block to base mounting screw: 19457

**DIMENSIONS**

Dimensions shown are metric (mm)

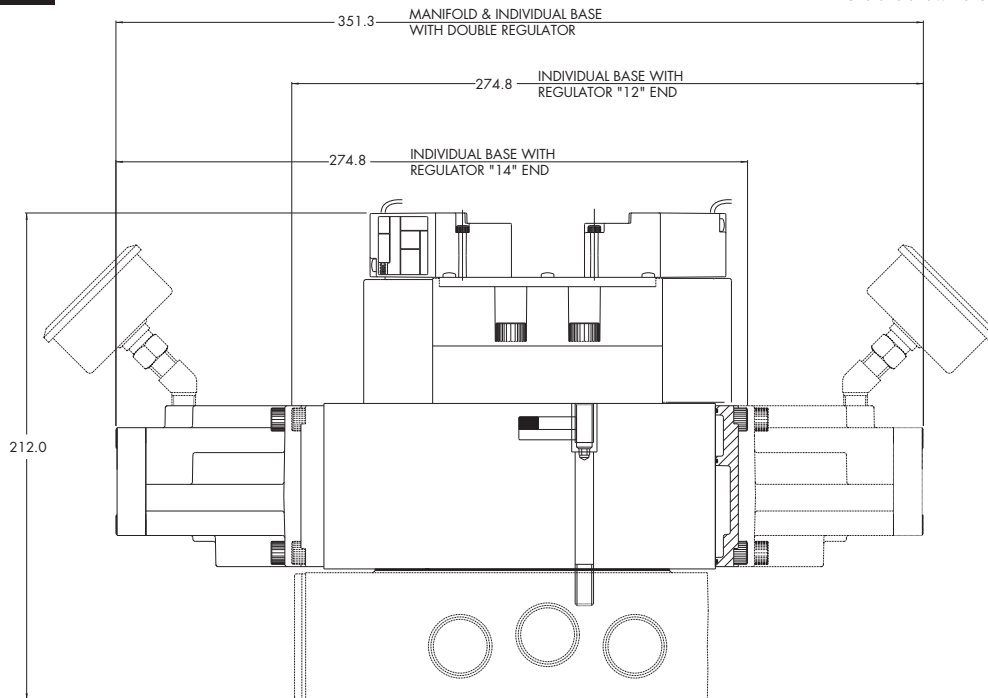



## Section 5

## Intrinsically Safe Valves

---



	Page
Specifications for Intrinsically Safe Valves	301
52 series	304
400 series	304
92 series	305



## INTRINSICALLY SAFE CIRCUIT

In order to use an intrinsically safe valve in a hazardous location, the installation must be in accordance with the following installation diagram :

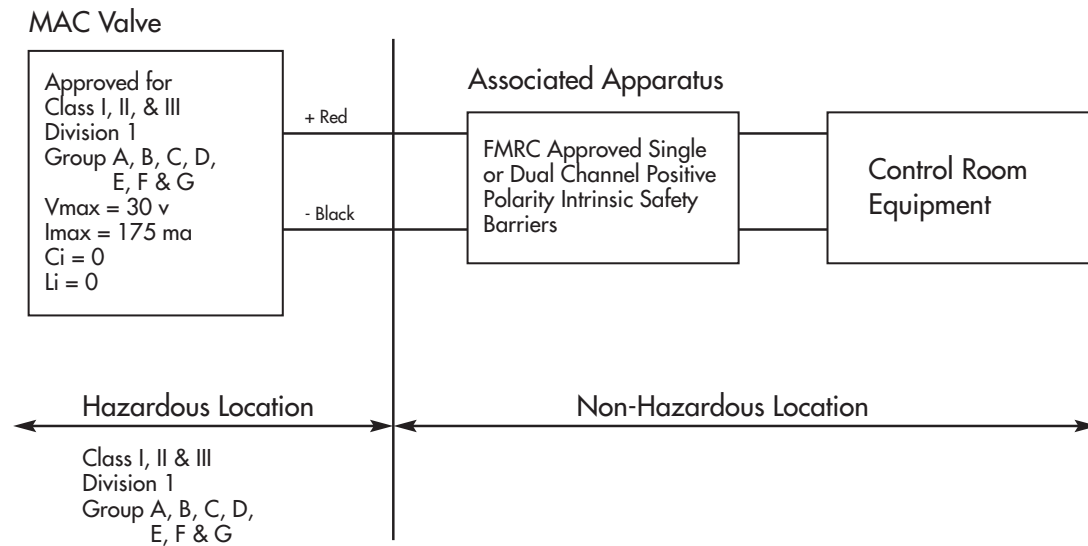

There are 3 basic parts to an intrinsically safe circuit :

### 1. FIELD DEVICE

This is defined as the device that will be used in the hazardous location. In this case, the field device will be the intrinsically safe valve.

### 2. ASSOCIATED APPARATUS

This will be an energy limiting device also known as a barrier.

### 3. FIELD WIRING

Wiring used to connect the two above devices.

When the MAC intrinsically safe valves were tested for approval, they were tested and approved for the following atmospheres.

Class I, II, III  
Division 1  
Groups ; A, B, C, D, E, F, G

under the following parameters :

Vmax : 30 VDC  
Imax : 175 ma  
Ci : 0  
Li : 0



---

What this means is that the intrinsically safe valves were tested against each atmosphere with up to 30 VDC and 175 ma of current across the solenoid and found to still be safe. The other two parameters are values to indicate how much energy can be stored or created by the valve :

Ci : Internal capacitance of the solenoid.

This indicates how much energy the solenoid is capable of storing.

Li : Internal inductance of the solenoid.

This indicates the solenoid's ability to create or increase energy beyond what is supplied.

When applying an intrinsically safe valve in a hazardous location, a proper barrier must first be selected. The barrier selection process must first take into account the parameters the valve was approved for and compared in the following way :

- Vmax must be greater than or equal to Voc of the barrier.  
Voc = Voltage open circuit or maximum allowed out of the barrier
- Imax must be greater than or equal to Isc of the barrier.  
Isc = Current short circuit or the maximum current allowed out of the barrier
- Ci plus field wiring must be less than Ca of the barrier.  
Ca = Allowed capacitance
- Li plus field wiring must be less than La of the barrier.  
La = Allowed inductance

When properly combined, the barrier will never allow more energy to the intrinsically safe valve than what it was tested and approved for.

The following page can be used as your guide to help ask the right questions when working with an intrinsically safe circuit. Also included is a partial list of intrinsically safe barriers that have been tested with the MAC intrinsically safe valves.



# Intrinsically Safe Valves

**Approval :** Factory Mutual Research 2X7A8.AX (3610)

Approved as intrinsically safe apparatus and associated apparatus for use in Class I, II, III - Division 1, Group : A, B, C, D, E, F & G.

**Parameters :** Vmax : 30 VDC

Imax : 175 ma

Ci : 0

Li : 0

Operating voltage greater than 11.5 volts

Coil resistance : Approximately 250 ohms

Current draw : 50 ma

Wattage : 0.6 watts

**Circuit Check Lists :**

- Is Vmax greater than or equal to Voc ?
- Is Imax greater than or equal to Isc ?
- Is Ci less than Ca ?
- Is Li less than La ?
- Is the barrier capable of handing 50 ma draw ?
- Is the internal resistance of the barrier 250 ohms or less ?

If all answers to the above questions are "yes" the barrier may be a good choice in combination with the MAC intrinsically safe valve.

To calculate voltage across the solenoid, plug values into the following equations :

$$I_{TOTAL} = \frac{\text{SUPPLY VOLTAGE}}{250 + \text{BARRIER RESISTANCE}} = \text{_____} \leftarrow \text{Plug } I_{TOTAL} \text{ in below}$$

Voltage at Solenoid =  $I_{TOTAL} \times 250 \text{ ohms} = \text{_____} \text{ volts}$

Manufacturer	Model #	Barrier Res.	Voltage w/o Light	Voltage w/Light	Groups	Type
Turck	MK72-S01-EX		11.2 v	10.2 v*	A-G	T.I.B.
Crouse-Hinds	SB19140-M2410		13.2 v	12.6 v	C-G	Zener
IMO Industries (Gems Sensors)	114072	234 OHMS	12.0 v	11.4 v	C-G	Zener
Pepperl & Fuchs	KHZ-922/EX-1	270 OHMS	11.6 v	11.06 v	A-G	Zener
	KHZ-922/EX-2	270 OHMS	11.6 v	11.06 v	A-G	Zener
	KHZ-922/EX-3	270 OHMS	11.6 v	11.06 v	A-G	Zener
Stahl	9001/01-280-165-10		13.5 v	12.9 v	C-G	Zener
	9351/10-14-10	80 OHMS	13.7 v	13.4 v	A-G	T.I.B.
Ronan	X57-229P	200 OHMS	12.7 v	12.05 v	C-G	Zener
Measurement Technology	MTL728P+	250 OHMS	11.9 v	11.4 v	A-G	Zener
	MTL3022		15.0 v	14.5 v	C-G	T.I.B.

Above data is based on a 24 v DC supply voltage to the input of the barrier. A 12 v DC, 243 OHM, .6 watt intrinsically safe solenoid is used. The measurement with light is an LED with a current limiting resistor.

Groups indicate what atmosphere the barrier has been approved for. All MAC intrinsically safe valves have been approved for Class I, II and III, Division 1, Groups A, B, C, D, E, F and G indoor hazardous locations.

T.I.B. = Transformer Isolated Barrier

\* = Not a recommended combination

**HOW TO ORDER**

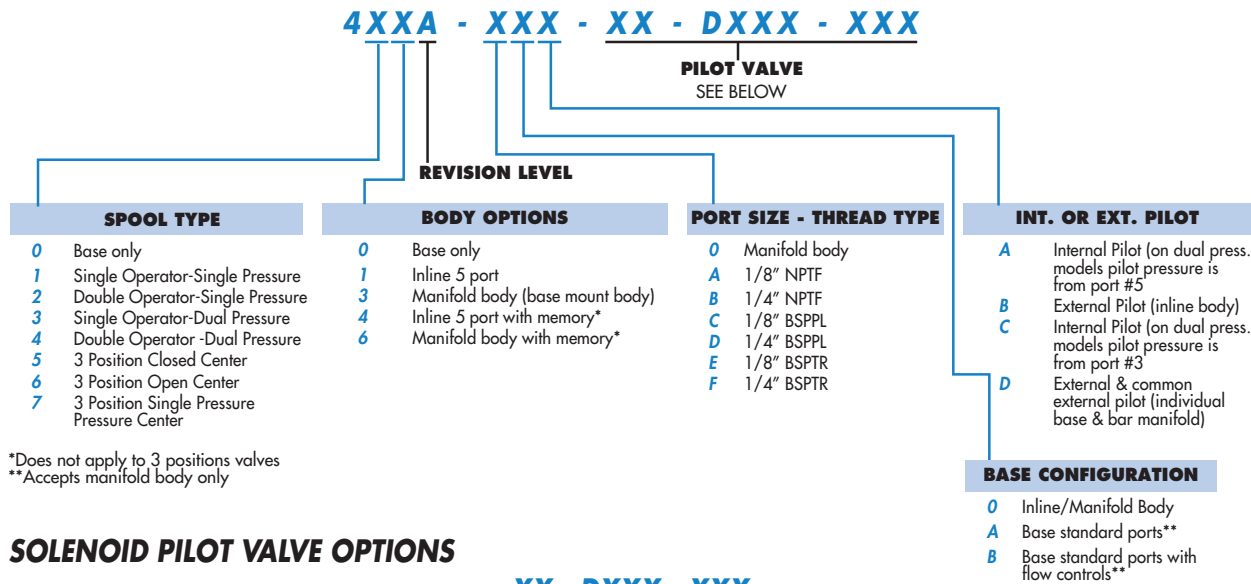
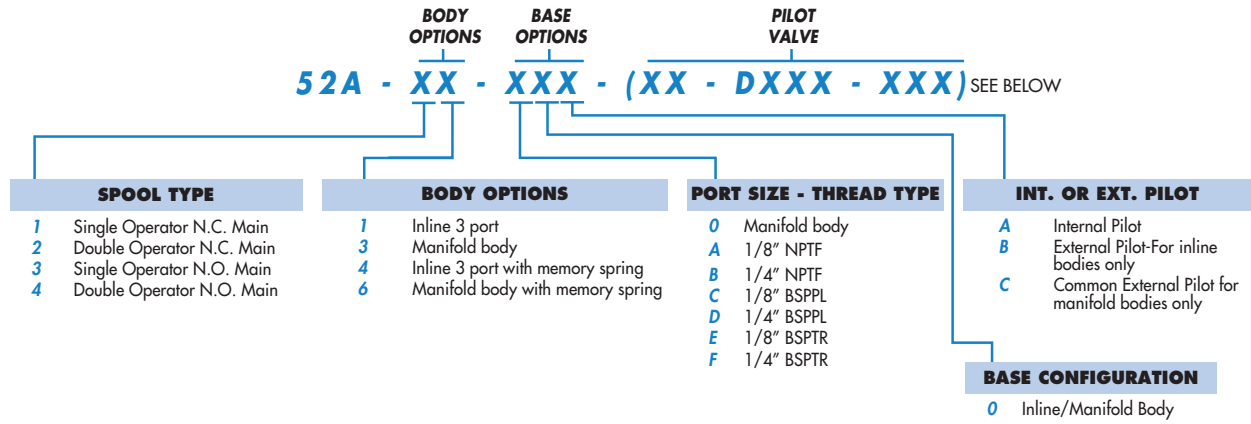

**SOLENOID PILOT VALVE OPTIONS**

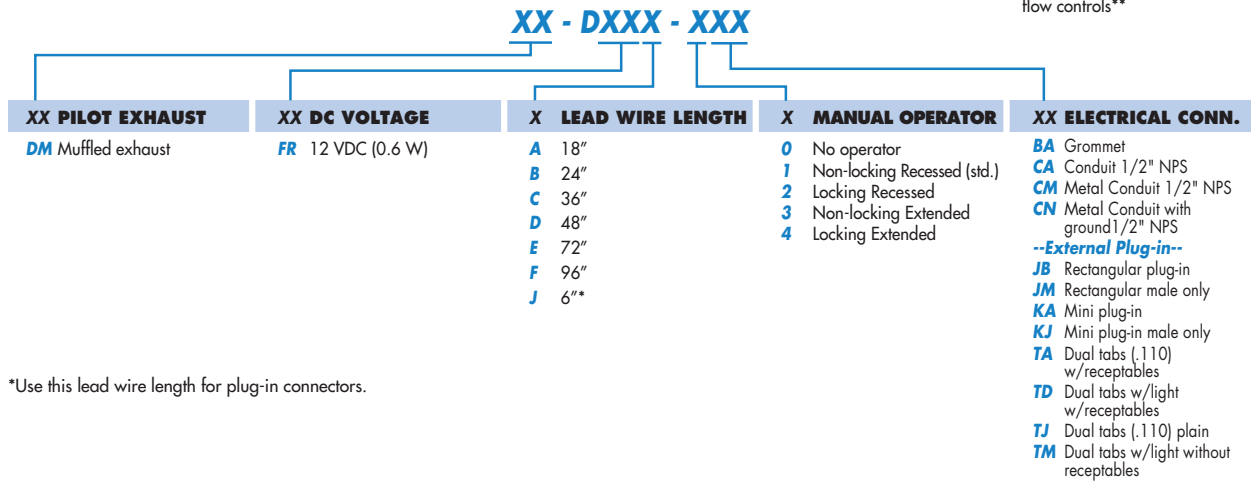

## HOW TO ORDER

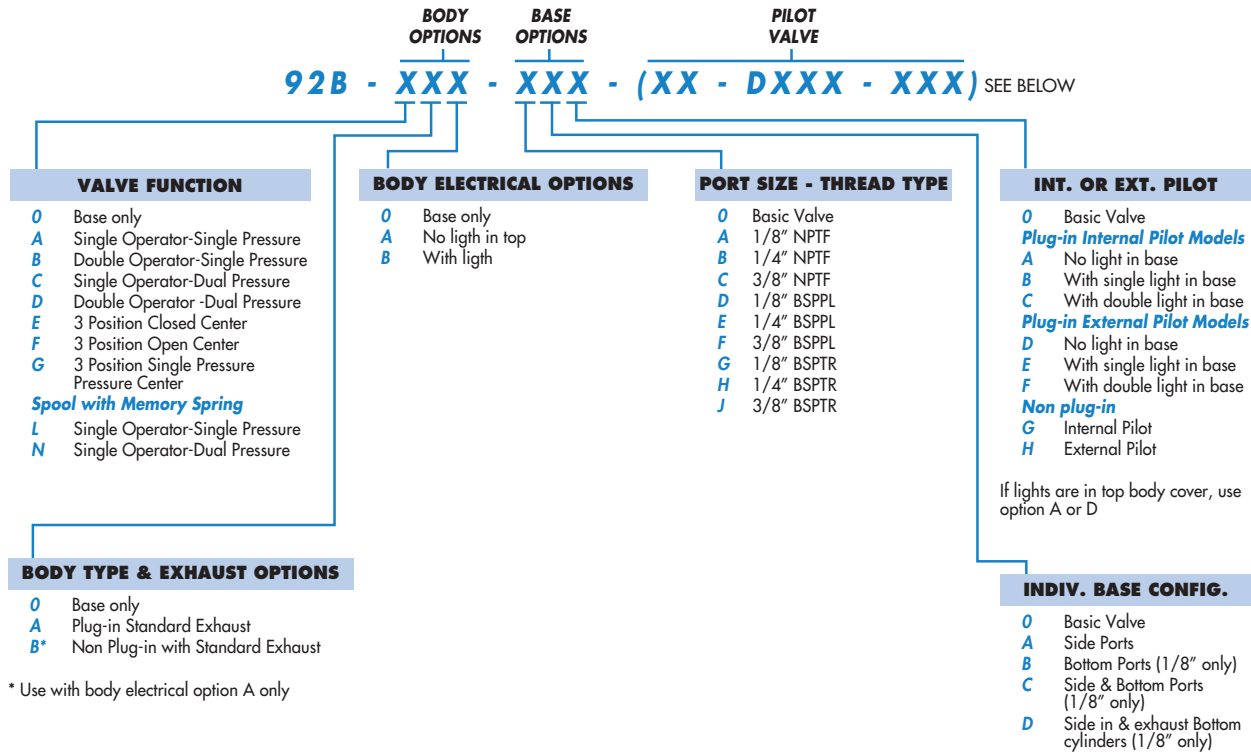

## PILOT VALVE OPTIONS

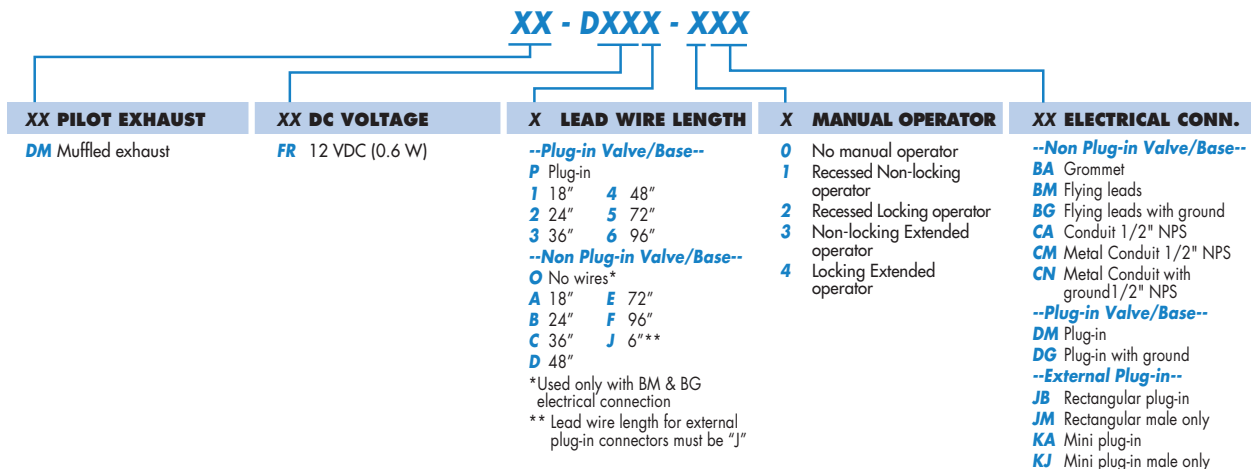

## HOW TO ORDER 92 SERIES FLOW CONTROL MODULE\*

FC 92C-AA	Plug-in flow control assembly single solenoid
FC 92C-BA	Plug-in flow control assembly double solenoid
FC 92C-CA	Non plug-in flow control assembly

\*If flow control module is to be installed between valve and base or valve and manifold at the factory, add -9 after the flow control model number, i.e., FC92C-AA-9. The flow control model number should follow the valve model number on which it is to be installed.

NOTE: If a flow control assembly is used with the dual pressure regulator option, only the flow control on the "B" end is functional. (Controls both cylinder ports.)  
NOTE: Consult the general catalog for regulator and circuit bar ordering information.





## Section 6

## Options

---

---

**Codification table for voltages / Manual operator / Electrical connection**

---

VALVE CODE > **-DM- D XX X-X XX**  
**1 2 3 4**

**OPTIONS AVAILABLE FOR**

- Pilot operated valves 52, 67, 92, 93, 400, ISO1, ISO2, ISO3 Series

---

1. VOLTAGE		4. ELECTRICAL CONNECTION	
<i>D-XX X-X XX</i>	VOLTAGE	<i>D-XX X-X XX</i>	ELECTRICAL CONNECTION
<i>DA</i>	24 VDC (5.4W)	<i>BA*</i>	Flying leads (grommet)
<i>DB</i>	12 VDC (5.4W)	<i>BK*</i>	BA with protection diode
<i>DC</i>	12 VDC (7.5W)	<i>BL*</i>	BA with protection varistor
<i>DD</i>	24 VDC (7.3W)	<i>BM**</i>	Flying leads (solenoid plug-in)
<i>DE</i>	12 VDC (12.7W)	<i>BN**</i>	BM with protection diode
<i>DF</i>	24 VDC (12.7W)	<i>BP**</i>	BM with protection varistor
<i>DK</i>	110 VDC (4.7W)	<i>BG**</i>	BM with ground
<i>DJ</i>	28 VDC (5.2W)	<i>BH**</i>	BM with protection diode & ground
<i>DL</i>	64 VDC (6.0W)	<i>BJ**</i>	BM with protection varistor & ground
<i>DM</i>	36 VDC (5.3W)	<i>CA*</i>	1/2" NPS conduit with flying leads
<i>DN</i>	6 VDC (6.0W)	<i>CM*</i>	1/2" NPS metal conduit with flying leads
<i>DR</i>	90 VDC (6.6W)	<i>CN*</i>	1/2" NPS metal conduit with flying leads & ground
<i>DS</i>	110 VDC (7.3W)	<i>JB</i>	Rectangular connector
<i>DT</i>	75 VDC (5.6W)	<i>JD</i>	JB with light
<i>DP</i>	48 VDC (5.8W)	<i>JM</i>	Rectangular connector (male only)
<i>FA</i>	12 VDC (1.8W)	<i>KA</i>	Mini square connector
<i>FB</i>	24 VDC (1.8W)	<i>KB</i>	KA with protection diode
<i>FE</i>	12 VDC (2.4W)	<i>KC</i>	KA with protection varistor
<i>FF</i>	24 VDC (2.4W)	<i>KD</i>	KA with light
<i>JA</i>	120/60, 110/50 (2.9W)	<i>KE</i>	KA with light and protection diode
<i>JB</i>	240/60, 220/50 (2.9W)	<i>KF</i>	KA with light and protection varistor
<i>JC</i>	24/60, 24/50 (3.7W)	<i>KG</i>	KA with light & diode
<i>JD</i>	100/60, 100/50, 110/60 (3.9W)	<i>KJ</i>	Mini square connector (male only)
<i>JE</i>	220/60 (3.4W)	<i>KK</i>	KJ with protection diode (male only)
<i>JF</i>	240/50 (2.8W)	<i>KL</i>	KJ with protection varistor (male only)
<i>JG</i>	200/60, 200/50 (3.9W)	<i>TA</i>	Dual tabs with receptacles
<b>2. WIRE LENGTH</b>		<i>TB</i>	TA with protection diode
<i>D-XX X-X XX</i>	WIRE LENGTH	<i>TD</i>	TA with light
<i>O</i>	No wires	<i>TE</i>	TA with light and protection diode
<i>A</i>	18"	<i>TJ</i>	Dual tabs (male only)
<i>B</i>	24"	<i>TK</i>	TJ with protection diode
<i>C</i>	36"	<i>TM</i>	TJ with light
<i>D</i>	48"	<i>TN</i>	TJ with light and protection diode
<i>E</i>	72"		
<i>F</i>	96"		
<b>3. MANUAL OPERATOR</b>			
<i>D-XX X-X XX</i>	MANUAL OPERATOR		
<i>0</i>	No operator		
<i>1</i>	Non-locking recessed		
<i>2</i>	Locking recessed		
<i>3</i>	Non-locking extended		
<i>4</i>	Locking extended		

\* From Lead wire length options choose A through F

\*\* From Lead wire length options choose 0 through F

Note: When coil is above 30 volts, a ground wire is required. Applies to options with flying leads.

---

**Codification table for voltages / Manual operator / Electrical connection**

---

VALVE CODE > **G XX X-X XX**  
**1 2 3 4**

**OPTIONS AVAILABLE FOR**

- Solenoid valves 32, 34, 38, 42, 44 & 48 Series

---

1. VOLTAGE		4. ELECTRICAL CONNECTION	
<b>G-XX X-X XX</b>	<b>VOLTAGE</b>	<b>G-XX X-X XX</b>	<b>ELECTRICAL CONNECTION</b>
<b>AA</b>	120 VAC (2.5W) Requires electrical connector with rectifier	<b>BA</b>	Flying leads
<b>AC</b>	24 VAC (4.0W) Requires electrical connector with rectifier	<b>BB</b>	BA with ground wire
<b>DA</b>	24 VDC (1.0W)	<b>BC</b>	BA with light
<b>DC</b>	24 VDC (1.8W)	<b>BD</b>	BA with light and ground wire
<b>DD</b>	24 VDC (2.5W)	<b>BE</b>	BA with suppression diode
<b>DE</b>	24 VDC (3.0W)	<b>BF</b>	BA with suppression diode and ground wire
<b>DF</b>	24 VDC (4.0W)	<b>BG</b>	BA with suppression diode and light
<b>DG</b>	12 VDC (1.0W)	<b>BH</b>	BA with suppression diode, light and ground wire
<b>DJ</b>	12 VDC (1.8W)	<b>BN</b>	BA with suppression diode and blocking diode
<b>DK</b>	12 VDC (2.5W)	<b>BP</b>	BA with suppression diode, blocking diode and ground wire
<b>DM</b>	12 VDC (3.0W)	<b>BR</b>	BA with suppression diode, blocking diode and light
<b>DN</b>	12 VDC (4.0W)	<b>BS</b>	BA with suppression diode, blocking diode, light and ground wire
<b>DR</b>	6 VDC (1.8W)	<b>GA</b>	MAC JAC Solenoid plug-in
<b>DS</b>	6 VDC (3.0W)	<b>GB</b>	MAC JAC Solenoid plug-in w/Diode
<b>EB</b>	48 VDC (1.8W)	<b>GC</b>	MAC JAC Solenoid plug-in w/MOV
<b>EC</b>	48 VDC (3.0W)	<b>GD</b>	MAC JAC Solenoid plug-in w/LED
<b>ED</b>	120 VDC (2.5W)	<b>GE</b>	MAC JAC Solenoid plug-in w/Diode & LED
<b>GD</b>	12 VDC (0.5W) 34 series only	<b>GF</b>	MAC JAC Solenoid plug-in w/MOV & LED
<b>GE</b>	24 VDC (0.5W) 34 series only	<b>GG</b>	MAC JAC Solenoid plug-in w/Rectifier
<b>2. WIRE LENGTH</b>		<b>GH</b>	MAC JAC Solenoid plug-in w/Rectifier & LED
<b>G-XX X-X XX</b>	<b>WIRE LENGTH</b>	<b>KA</b>	Solenoid plug-in wire assembly
<b>0</b>	No lead wires (used only with "KJ" & "KM" connectors)	<b>KB</b>	KA with ground
<b>A</b>	18" coil leads	<b>KC</b>	KA with rectifier and light
<b>B</b>	24" coil leads	<b>KD</b>	KA with rectifier, light and ground
<b>C</b>	36" coil leads	<b>KE</b>	KA with suppression diode
<b>D</b>	48" coil leads	<b>KF</b>	KA with suppression diode and ground
<b>E</b>	72" coil leads	<b>KJ</b>	Solenoid plug-in housing without wire assembly
<b>F</b>	96" coil leads	<b>KM</b>	Solenoid plug-in housing with ground pin without wire assembly
<b>G</b>	120" coil leads	<b>KN</b>	KA with suppression diode and blocking diode
<b>H</b>	144" coil leads	<b>KP</b>	KA with suppression diode, blocking diode and ground
<b>I</b>	18" base leads	<b>KT</b>	KA with light
<b>2</b>	24" base leads	<b>KU</b>	KA with light and ground
<b>3</b>	36" base leads	<b>KV</b>	KA with suppression diode and light
<b>4</b>	48" base leads	<b>KW</b>	KA with suppression diode, light and ground
<b>5</b>	72" base leads	<b>KX</b>	KA with suppression diode, blocking diode and light
<b>6</b>	96" base leads	<b>KY</b>	KA with suppression diode, blocking diode, light & ground
<b>7</b>	120" base leads	<b>ELECTRICAL CONNECTION FOR PLUG-IN VALVES</b>	
<b>3. MANUAL OPERATOR</b>		<b>G-XX X-X XX</b>	<b>PLUG-IN OPTIONS</b>
<b>G-XX X-X XX</b>	<b>MANUAL OPERATOR</b>	<b>SB</b>	Base plug-in with ground
<b>1</b>	Non-locking recessed	<b>SC</b>	Base plug-in with suppression and blocking diode
<b>2</b>	Locking recessed	<b>SD</b>	Base plug-in with suppression and blocking diode and ground
<b>3</b>	Non-locking extended	<b>SE</b>	Base plug-in with MOV
<b>4</b>	Locking extended	<b>SF</b>	Base plug-in with MOV and ground
		<b>SG</b>	Base plug-in with rectifier
		<b>SH</b>	Base plug-in with rectifier and ground
		<b>SK</b>	Base plug-in with light and ground
		<b>SL</b>	Base plug-in with suppression and blocking diode and light
		<b>SM</b>	Base plug-in with suppression and blocking diode with light and ground
		<b>SN</b>	Base plug-in with MOV and light
		<b>SP</b>	Base plug-in with MOV and light with ground
		<b>SR</b>	Base plug-in with rectifier and light



---

**Codification table for voltages / Manual operators / Electrical connections**

---

VALVE CODE > **-GM- G XX X-X XX**  
**1 2 3 4**

**OPTIONS AVAILABLE FOR**

- Solenoid valves 52 & 400 Series

---

1. VOLTAGE		4. ELECTRICAL CONNECTION	
<b>G-XX X-X XX</b>	<b>VOLTAGE</b>	<b>G-XX X-X XX</b>	<b>ELECTRICAL CONNECTION</b>
<b>DC</b>	24 VDC (1.8 W)	<b>BA</b>	Flying leads
<b>DD</b>	24 VDC (2.5 W)	<b>BB</b>	BA with ground wire
<b>DE</b>	24 VDC (3.0 W)	<b>BC</b>	BA with light parallel to leads
<b>DF</b>	24 VDC (4.0 W)	<b>BD</b>	BA with light parallel to leads & ground wire
<b>DJ</b>	12 VDC (1.8 W)	<b>BE</b>	BA with suppression diode
<b>DK</b>	12 VDC (2.5 W)	<b>BF</b>	BA with suppression diode & ground wire
<b>DM</b>	12 VDC (3.0 W)	<b>BG</b>	BA with suppression diode plus light parallel to leads
<b>DN</b>	12 VDC (4.0 W)	<b>BH</b>	BA with suppression diode plus light parallel to leads & ground wire
<b>2. WIRE LENGTH</b>		<b>*BN</b>	BA with suppression diode plus blocking diode
<b>G-XX X-X XX</b>	<b>WIRE LENGTH</b>	<b>*BP</b>	BA with suppression diode plus blocking diode & ground wire
<b>O</b>	No lead wire (use only with "KJ" & "KM" electrical connectors)	<b>*BR</b>	BA with suppression diode plus blocking diode & light parallel to leads
<b>A</b>	18"	<b>*BS</b>	BA with suppression diode plus blocking diode & light parallel to leads & ground wire
<b>B</b>	24"	<b>BT</b>	BA with light on top
<b>C</b>	36"	<b>BU</b>	BA with light on top & ground wire
<b>D</b>	48"	<b>BV</b>	BA with suppression diode plus light on top
<b>E</b>	72"	<b>BW</b>	BA with suppression diode plus light on top & ground wire
<b>F</b>	96"	<b>*BX</b>	BA with suppression diode plus blocking diode & light on top
<b>G</b>	120"	<b>*BY</b>	BA with suppression diode plus blocking diode & light on top & ground wire
<b>H</b>	144"		
<b>3. MANUAL OPERATOR</b>		<b>G-XX X-X XX</b>	<b>SOLENOID PLUG-IN CONNECTOR WITH LEADS</b>
<b>G-XX X-X XX</b>	<b>MANUAL OPERATOR</b>	<b>GA</b>	MAC JAC Solenoid plug-in
<b>1</b>	Non-locking recessed	<b>GB</b>	MAC JAC Solenoid plug-in w/Diode
<b>2</b>	Locking recessed	<b>GC</b>	MAC JAC Solenoid plug-in w/MOV
<b>3</b>	Non-locking extended	<b>GD</b>	MAC JAC Solenoid plug-in w/LED
<b>4</b>	Locking extended	<b>GE</b>	MAC JAC Solenoid plug-in w/Diode & LED
		<b>GF</b>	MAC JAC Solenoid plug-in w/MOV & LED
		<b>GG</b>	MAC JAC Solenoid plug-in w/Rectifier
		<b>GH</b>	MAC JAC Solenoid plug-in w/Rectifier & LED
		<b>KA</b>	Plug-in wire assembly
		<b>KB</b>	KA with ground wire
		<b>KE</b>	KA with suppression diode
		<b>KF</b>	KA with suppression diode & ground wire
		<b>KJ</b>	Plug-in housing without wire assembly ('KA' without wire assembly)
		<b>KM</b>	Plug-in housing without wire assembly ('KB' without wire assembly)
		<b>*KN</b>	KA with suppression diode plus blocking diode
		<b>*KP</b>	KA with suppression diode plus blocking diode & ground wire
		<b>KT</b>	KA with light on top
		<b>KU</b>	KA with light on top & ground wire
		<b>KV</b>	KA with suppression diode plus light on top
		<b>KW</b>	KA with suppression diode plus light & ground wire
		<b>*KX</b>	KA with suppression diode plus blocking diode & light on top
		<b>*KY</b>	KA with suppression diode plus blocking diode & light on top & ground wire

Note: Blocking diode is located in the lead wire

---

**Codification table for voltages / Manual operators / Electrical connections**

---

VALVE CODE >  **$\frac{H}{1} \frac{XX}{2} \frac{X-X}{3} \frac{XX}{4}$**

**OPTIONS AVAILABLE FOR**

- Solenoid valves 37 & 47 Series

---



1. VOLTAGE		H-XX X-X XX	
<b>H-XX X-X XX</b>	<b>VOLTAGE</b>	<b>BL</b>	BA with full wave rectifier & ground wire
<b>AA</b>	120/50, 120/60 (6.7 W) (use connector with rectifier)	<b>BT</b>	BA with full wave rectifier plus light
<b>AB</b>	220/50, 220/60 (5.6 W) (use connector with rectifier)	<b>BU</b>	BA with full wave rectifier plus light & ground wire
<b>AC</b>	240/50, 240/60 (5.8 W) (use connector with rectifier)	<b>H-XX X-X XX</b> <b>PLUG-IN CONNECTOR</b>	
<b>AD</b>	24/50, 24/60 (7.8 W) (use connector with rectifier)	<b>FA</b>	Base plug-in
<b>DA</b>	24 VDC (5.2 W)	<b>FB</b>	FA with ground wire
<b>DB</b>	24 VDC (2.4 W)	<b>FC</b>	FA with light
<b>DC</b>	24 VDC (1.8 W)	<b>FD</b>	FA with light & ground wire
<b>DD</b>	24 VDC (1.0 W)	<b>FE</b>	FA with suppression diode
<b>DF</b>	12 VDC (5.2 W)	<b>FF</b>	FA with suppression diode & ground wire
<b>DG</b>	12 VDC (2.4 W)	<b>FG</b>	FA with suppression diode & light
<b>DH</b>	12 VDC (1.8 W)	<b>FH</b>	FA with suppression diode plus light & ground wire
<b>DJ</b>	12 VDC (1.0 W)	<b>FK</b>	FA with full wave rectifier
<b>DL</b>	120 VDC (6.3 W)	<b>FL</b>	FA with full wave rectifier & ground wire
<b>2. WIRE LENGTH</b>		<b>*FN</b>	FA with suppression diode plus blocking diode
<b>H-XX X-X XX</b>	<b>WIRE LENGTH</b>	<b>*FP</b>	FA with suppression diode plus blocking diode & ground wire
<b>0</b>	No lead wire (use with "MJ, MM & K Type connectors)	<b>*FR</b>	FA with suppression diode plus blocking diode plus light
<b>A</b>	18"	<b>*FS</b>	FA with suppression diode plus blocking diode & light & ground wire
<b>B</b>	24"	<b>FT</b>	FA with full wave rectifier plus light
<b>C</b>	36"	<b>FU</b>	FA with full wave rectifier plus light & ground wire
<b>D</b>	48"	<b>MA</b>	Solenoid plug-in wire assembly
<b>E</b>	72"	<b>MB</b>	MA with ground wire
<b>F</b>	96"	<b>MC</b>	MA with light
<b>G</b>	120"	<b>MD</b>	MA with light & ground wire
<b>H</b>	144"	<b>ME</b>	MA with suppression diode
<b>3. MANUAL OPERATOR</b>		<b>MF</b>	MA with suppression diode & ground wire
<b>H-XX X-X XX</b>	<b>MANUAL OPERATOR</b>	<b>MG</b>	MA with suppression diode plus light
<b>0</b>	No operator	<b>MH</b>	MA with suppression diode plus light & ground wire
<b>1</b>	Non-locking recessed	<b>MK</b>	MA with full wave rectifier
<b>2</b>	Locking recessed	<b>ML</b>	MA with full wave rectifier & ground wire
<b>3</b>	Non-locking extended	<b>*MN</b>	MA with suppression diode plus blocking diode
<b>4</b>	Locking extended	<b>*MP</b>	MA with suppression diode plus blocking diode & ground wire
<b>4. ELECTRICAL CONNECTION</b>		<b>*MR</b>	MA with suppression diode plus blocking diode & light
<b>H-XX X-X XX</b>	<b>ELECTRICAL CONNECTION</b>	<b>*MS</b>	MA with suppression diode plus blocking diode & light & ground wire
<b>BA</b>	Flying leads	<b>MT</b>	MA with full wave rectifier plus light
<b>BB</b>	BA with ground wire	<b>MU</b>	MA with full wave rectifier plus light & ground wire
<b>BC</b>	BA with light	<b>MJ</b>	Plug-in housing without wire assembly ('MA' option without wire assembly)
<b>BD</b>	BA with light & ground wire	<b>MM</b>	Plug-in housing without wire assembly ('MB' option without wire assembly)
<b>BE</b>	BA with suppression diode	<b>KA</b>	Mini square connector
<b>BF</b>	BA with suppression diode & ground wire	<b>KB</b>	KA with suppression diode
<b>BG</b>	BA with suppression diode plus light	<b>KC</b>	KA with M.O.V.
<b>BH</b>	BA with suppression diode plus light & ground wire	<b>KD</b>	KA with light
<b>*BN</b>	BA with suppression diode plus blocking diode	<b>KE</b>	KA with light & suppression diode
<b>*BP</b>	BA with suppression diode plus blocking diode & ground wire	<b>KF</b>	KA with light & M.O.V.
<b>*BR</b>	BA with suppression diode plus blocking diode & light	<b>KJ</b>	Mini square connector – male only
<b>*BS</b>	BBA with suppression diode plus blocking diode & light & ground wire	<b>KK</b>	KJ with suppression diode
<b>BK</b>	BA with full wave rectifier	<b>KL</b>	KJ with M.O.V.
		<b>KM</b>	KA with full wave rectifier
		<b>KN</b>	KA with full wave rectifier & M.O.V.
		<b>KP</b>	KA with full wave rectifier & light
		<b>KR</b>	KA with full wave rectifier plus light & M.O.V.
		<b>KS</b>	KJ with full wave rectifier

\* Blocking diode is located in the lead wire

---

**Codification table for voltages / Manual operators / Electrical connections**

---

VALVE CODE >  $J \frac{XX}{1} \frac{X-X}{23} \frac{XX}{4}$

**OPTIONS AVAILABLE FOR**

- Solenoid valves 36, 46, ISO 01 and ISO 02 Series

---

### 1. VOLTAGE

J-XX X-X XX	VOLTAGE
AA	120VAC (5.4W)
AC	24VAC (5.4W)
DE	24VDC (1.8W)
DF	12VDC (1.8W)
DJ	24VDC (1.3W)
DL	12VDC (1.3W)
DR	12VDC (1.0W)*
DU	24VDC (1.0W)*

\* Not available on 36 series universal valve

### 2. WIRE LENGTH

J-XX X-X XX	WIRE LENGTH
A	18" coil leads
B	24" coil leads
C	36" coil leads
D	48" coil leads
E	72" coil leads
F	96" coil leads
P	Base plug-in
O	No leads (use with J, K & L type connectors)

### 3. MANUAL OPERATOR

J-XX X-X XX	MANUAL OPERATOR
0	No operator
1	Non-locking recessed
2	Locking recessed
3	Non-locking extended
4	Locking extended

### 4. ELECTRICAL CONNECTION

J-XX X-X XX	ELECTRICAL CONNECTION
BA	Flying leads
GA	MAC JAC solenoid plug-in
GB	MAC JAC solenoid plug-in with diode
GC	MAC JAC solenoid plug-in with MOV
GD	MAC JAC solenoid plug-in with light
GE	MAC JAC solenoid plug-in with diode and light
GF	MAC JAC solenoid plug-in with MOV and light
GG	MAC JAC solenoid plug-in with rectifier
GH	MAC JAC solenoid plug-in with rectifier and light
GJ	MAC JAC solenoid plug-in - Male only
GK	MAC JAC solenoid plug-in with diode - Male only
GL	MAC JAC solenoid plug-in with MOV - Male only
GM	MAC JAC solenoid plug-in with light - Male only
GN	MAC JAC solenoid plug-in with diode and light - Male only
GP	MAC JAC solenoid plug-in with MOV and light - Male only
GR	MAC JAC solenoid plug-in with rectifier - Male only
GS	MAC JAC solenoid plug-in with rectifier and light - Male only
*JA	Square Connector
*JC	Square Connector with light
*JE	Square Connector with diode
*JF	Square Connector with MOV
*JG	Square Connector with diode/light
*JH	Square Connector with MOV /light
*JK	Square Connector with Rectifier

### J-XX X-X XX

*JL	Square Connector with Rectifier with light
*JJ	Square Connector Male only (Plain)
*JB	Rectangular Connector
*JD	Rectangular Connector with light
*JN	Rectangular Connector with diode
*JP	Rectangular Connector with MOV
*JR	Rectangular Connector with diode/light
*JS	Rectangular Connector with MOV /light
*JT	Rectangular Connector with Rectifier
*JU	Rectangular Connector with Rectifier with light
*JM	Rectangular Connector Male only (Plain)

\* Not available on manifold or stacking valves

### CONNECTORS FOR NON PLUG-IN VALVES

J-XX X-X XX	MINI SQUARE PLUG-IN CONNECTORS 9.4 MM SPACING BETWEEN PINS
KA	Mini plug-in
KB	Mini plug-in with diode
KC	Mini plug-in with MOV
KD	Mini plug-in with light
KE	Mini plug-in with diode and light
KF	Mini plug-in with MOV and light
KG	Mini plug-in with rectifier
KH	Mini plug-in with rectifier and light
KJ	Mini plug-in - Male only
KK	Mini plug-in with diode - Male only
KL	Mini plug-in with MOV - Male only
KM	Mini plug-in with light - Male only
KN	Mini plug-in with diode and light - Male only
KP	Mini plug-in with MOV and light - Male only
KR	Mini plug-in with rectifier - Male only
KS	Mini plug-in with rectifier and light - Male only

### CONNECTORS FOR NON PLUG-IN VALVES

J-XX X-X XX	MINI SQUARE PLUG-IN CONNECTORS 8.0 MM SPACING BETWEEN PINS ISO SPECIFICATION 15217
LA	Mini plug-in
LB	Mini plug-in with diode
LC	Mini plug-in with MOV
LD	Mini plug-in with light
LE	Mini plug-in with diode and light
LF	Mini plug-in with MOV and light
LG	Mini plug-in with rectifier
LH	Mini plug-in with rectifier and light
LJ	Mini plug-in - Male only
LK	Mini plug-in with diode - Male only
LL	Mini plug-in with MOV - Male only
LM	Mini plug-in with light - Male only
LN	Mini plug-in with diode and light - Male only
LP	Mini plug-in with MOV and light - Male only
LR	Mini plug-in with rectifier - Male only
LS	Mini plug-in with rectifier and light - Male only

### J-XX X-X XX

J-XX X-X XX	CONNECTORS FOR PLUG-IN VALVES
FA	Base plug-in
FB	Base plug-in with diode
FC	Base plug-in with MOV
FD	Base plug-in with light
FE	Base plug-in with diode and light
FF	Base plug-in with MOV and light
FG	Base plug-in with rectifier
FH	Base plug-in with rectifier and light

---

**Codification table for voltages / Manual operators / Electrical connections**

---

VALVE CODE > **R XX X-X XX**  
**1 2 3 4**

**OPTIONS AVAILABLE FOR**

- Solenoid valves 33 Series

---

### 1. VOLTAGE

R-XX X-X XX	VOLTAGE
DA	24 VDC (0.5W)
DB	24 VDC (1.0W)
DC	24 VDC (1.8W)
DD	24 VDC (2.5W)
DE	24 VDC (3.0W)
DF	24 VDC (4.0W)
DG	12 VDC (0.5W)
DH	12 VDC (1.0W)
DJ	12 VDC (1.8W)
DK	12 VDC (2.5W)
DL	12 VDC (3.0W)
DM	12 VDC (4.0W)
EA*	24 VDC (60W)
EB*	24 VDC (90W)
EC*	24 VDC (230W)

### 2. WIRE LENGTH (all series)

R-XX X-X XX	WIRE LENGTH
0**	No lead wire
A	18"
B	24"
C	36"
D	48"
E	72"
F	96"
G	120"
H	144"

### 3. MANUAL OPERATOR

R-XX X-X XX	MANUAL OPERATOR
0	No operator
1	Non-locking recessed
3	Non-locking extended

### 4. ELECTRICAL CONNECTOR

R-XX X-X XX	NON PLUG-IN
BA	Flying leads
BB	Flying leads with LED
BC	Flying leads with MOV
BD	Flying leads with LED and MOV
RA	Mini JAC solenoid plug-in
RB	Mini JAC solenoid plug-in with LED
RC	Mini JAC solenoid plug-in with MOV
RD	Mini JAC solenoid plug-in with LED and MOV
TA	JST solenoid plug-in
TB	JST solenoid plug-in with LED
TC	JST solenoid plug-in with MOV
TD	JST solenoid plug-in with LED and MOV

\*MOD numbers required for these voltages (consult factory) \*\* Not available for flying leads connector



## Section 7

## Supplemental technical information

---

## MAC's PATENTED LATCHING SOLENOID – Eliminates one Solenoid, Simplifies Wiring, Reduces Package Size

MAC's latching solenoid technology provides the function of a double solenoid operated valve utilizing only one solenoid.

Typical 2 position direct operated double solenoid valves use two solenoids with spool/bore technology. When the power is removed from either solenoid, the spool position and valve function is maintained.

With direct acting solenoid valves, poppets with their inherent short strokes are not typically used as they cannot maintain sealing position when both solenoids are deenergized. As a consequence, longer stroking spool type solenoid valves are used which results in lower shifting forces. MAC's latching solenoid technology eliminates the sealing issue with poppets when no electrical signal is applied, by maintaining solenoid force, ensuring adequate sealing, while using short stroking poppets resulting in high shifting forces.

MAC's latching solenoid only requires one solenoid and correspondingly one plug-in and one conduit wireway versus two for conventional double solenoid valve, saving space, weight and cost. An added benefit of a latching solenoid valve when mounted on a circuit bar is the additional option of side cylinder ports.

### HOW IT WORKS

Unlike a spool and bore valve, a poppet valve requires that a force be continuously applied to either end of the poppet to ensure that proper sealing occurs. If another solenoid was simply added to the valve to create a double solenoid valve, power would need to be constantly applied to either solenoid for the valve to function properly (see Figure 1). If the poppet valve is converted to a spool and bore type valve design, the longer stroke of the spool and solenoid would result in lower net shifting forces (see Figure 2), compromising the valves shifting reliability.

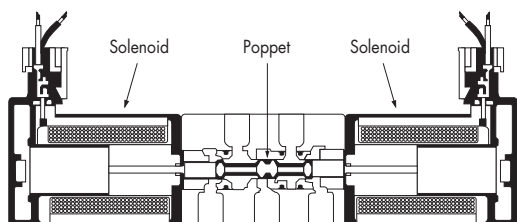

Figure 1 : Double Solenoid Poppet

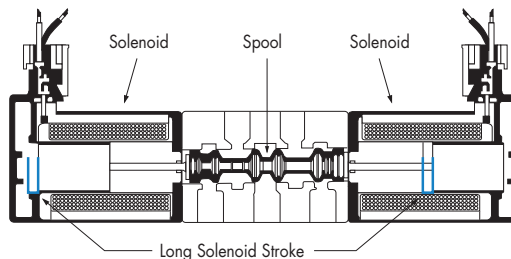

Figure 2 : Double Solenoid Spool Design

The latching solenoid overcomes these problems by introducing a powerful permanent magnet armature assembly which magnetically latches itself to the pole piece and in turn keeps the poppet sealed against the conical seats when the power is removed from the solenoid. To shift the poppet in the opposite direction, the polarity of the voltage applied to the solenoid leads is reversed and the attractive force between the permanent magnet armature assembly and the pole piece is reduced. The return spring in the valve then shifts the poppet to its other sealing position and the permanent magnet armature assembly is then magnetically attracted to the upper latch. The upper latch prevents the permanent magnet armature assembly from attracting itself back to the pole piece when the voltage is removed. Reversing the polarity again to the solenoid lead wires will create a powerful attractive force between the permanent magnet armature assembly and the pole piece and away from the upper latch which will correspondingly move the poppet to the other shifted position.

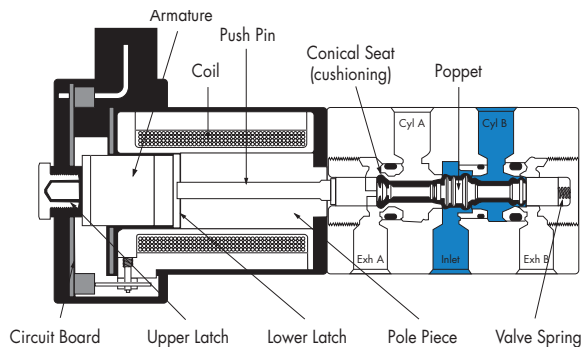

Figure 3 : Latching Solenoid Design

## WIRING INSTRUCTIONS AND OPTIONS

As shown in Figure 4, a conventional double solenoid valve requires that the pair of lead wires from each solenoid be wired to an appropriate voltage source, MAC's latching solenoid technology has the option of being wired in one of the three (3) currently available methods.

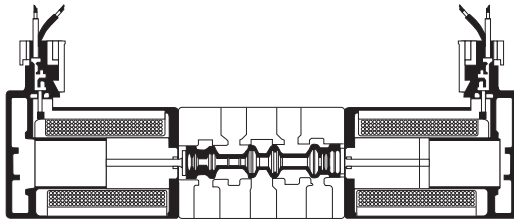
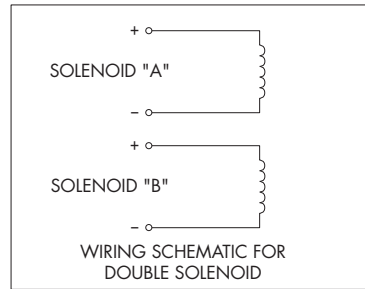

Figure 4 : Conventional Double Solenoid



### FOUR WIRE

As shown in Figure 5, the four wire method enables the coil to be wired as if it were a conventional double solenoid. By connecting the yellow lead wire to positive voltage and the yellow lead wire with black stripe to negative, the valve will be open to cylinder port "A". When positive voltage is supplied to the red lead wire and negative to the red lead with a black stripe, the valve will now be open to cylinder port "B". Since the negative red and yellow lead wires are internally connected together, the supply voltage for each pair of yellow and red lead wires must be isolated from the other pair (see diagram). Also, power must not be applied to all four leads simultaneously or a short circuit condition will occur possibly damaging the voltage source.

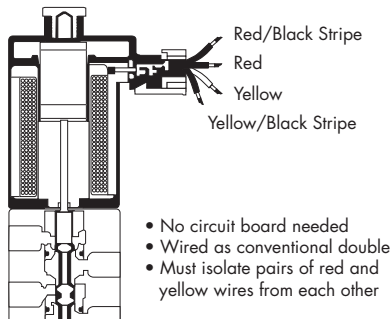
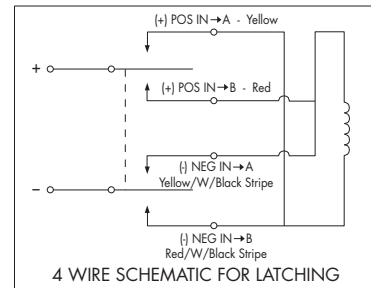

Figure 5 : Four Wire Latching



### THREE WIRE

Unlike the two wire method ( see Figure 7) which requires the user to provide the polarity switching circuitry, the three wire method incorporates the polarity switching circuitry within the solenoid enclosure ( see Figure 6). The black lead wire provided must be connected to positive and is used as a common. When negative voltage is supplied to the yellow lead wire with a black stripe the valve will be open to cylinder port "A". When the negative voltage is removed from the yellow lead wire with the black stripe and supplied to the red lead wire with a black stripe, the valve will now be open to cylinder port "B". Applying voltage to all three wires simultaneously or with the wrong polarity will cause permanent damage to the switching circuitry in the solenoid cover, and the valve won't work.

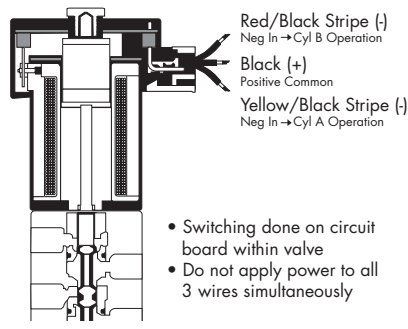
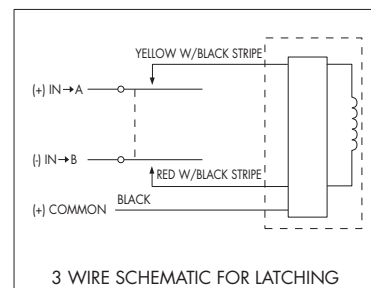

Figure 6 : Three Wire Latching





#### TWO WIRE

The two wire method shown in Figure 7, provides a black and red lead wire connected to the solenoid. The user must provide the polarity switching circuitry to these leads in order to shift the valve to its two positions. By applying positive DC voltage to the red lead wire and negative to the black, the valve will be open to cylinder port "A". When the polarity of the voltage is externally reversed to the lead wires the valve will now become open to cylinder port "B".

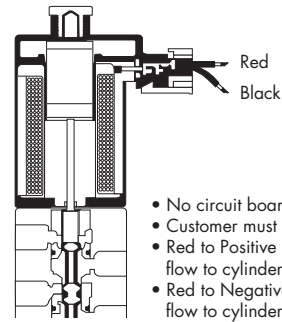

Figure 7 : Two Wire Latching

- No circuit board needed
- Customer must switch polarity of voltage
- Red to Positive and Black to Negative yields flow to cylinder port A
- Red to Negative and Black to Positive yields flow to cylinder port B

---

#### AVAILABLE OPTIONS

The 2 and 4 wire connections are available in both a flying lead and plug-in cover. The 3 wire connection is only available in the plug-in style cover. All 2 and 4 wire cover options are available with an LED indicator. The LED indicator on a 3 wire cover is standard. The LED will illuminate red for cylinder "A" operation and green for cylinder "B" operation.

The 3 wire connection must be used for valves connected to either a multi-pin connector or a serial manifold. Mixing single solenoids with latching solenoids on a circuit bar is possible since each station of the bar is wired for a latching coil. The circuit bar must be ordered with this wiring configuration. If required, a negative common 3 wire connection is also available, please consult factory.

---

#### HOW TO ORDER

The numbering system for a latching solenoid differs from the numbering system for a single solenoid valve. The letter "L" within the model number indicates a latching solenoid, while the letter "G" or "H" in the same position of the model number indicates a single solenoid valve.

## PRECAUTIONS AND WARNINGS CONCERNING THE APPLICATION, INSTALLATION AND SERVICE OF MAC VALVES AND OTHER MAC VALVES PRODUCTS

The warnings and precautions below are important to be read and understood before designing into a system any MAC Valves products, and before installing or servicing any MAC Valves product. Improper use, installation or servicing of any MAC Valves product in some systems could create a hazard to personnel or equipment. No distinction in importance should be made between the terms warnings and precautions.

### WARNING :

Under no circumstances are MAC Valves products to be used in any application or in any manner where failure of the MAC Valves product to operate as intended could in any way jeopardize the safety of the operator or any other person or property.

- Do not operate outside of pressure range listed on a valve label or outside of the designated temperature range.
- Air supply must be clean and dry. Moisture or contamination can affect proper operation of the valve.
- Before attempting to repair, adjust or clean a MAC Valves product, consult catalog, parts & operation sheet, or factory for proper maintenance procedures, lubrication and cleaning agents. Never attempt to repair or perform other maintenance with air pressure to the valve.
- If air line lubrication is used do not use any lubrication other than those recommended in the catalog, parts & operation sheet or by the factory.

### APPLICATION PRECAUTIONS :

#### INDUSTRIAL USE -

- MAC Valve products are intended for general use in industrial pneumatic and/or vacuum systems. They are general purpose industrial products with literally thousands of different applications in industrial systems. These products are not inherently dangerous, but they are only a component of an overall system. The system in which they are used must provide adequate safeguards to prevent injury or damage in the event failure occurs, whether it be failure of switches, regulators, cylinders, valves or any other component.

#### POWER PRESSES -

MAC Valve products are not designed nor intended to be used to operate and/or control the operation of clutch and/or brake systems on power presses. There are special products on the market for such use.

#### 2-POSITION VALVES -

Some MAC valves are 2-position, 4-way valves. When air is supplied to the inlet port(s) of these valves, there will always be a flow path from the inlet to one of the outlets regardless of which of the two positions the valve is situated. Therefore, if pressurized air retained in the system would present a hazard in the application or servicing of the valve or system, a separate method in the system must be provided to remove the trapped air.

#### 3- POSITION VALVES-

Some MAC valves are 3-position, 4-way valves. These valves are either double solenoid or double remote air operated.

If either of the two operators is in control, air supplied to the inlet port(s) will pass through the valve to one of the outlets as on 2-position, 4-way valves. However, if neither operator is in control, the valve moves to a center position. Listed below are the various center position functions :

#### A. CLOSED CENTER-

With this type valve, when in the center position all ports are blocked (inlets and exhausts) meaning the air at both outlet ports is trapped. If trapping the air in both outlet ports would present a hazard in the application or servicing, a separate method in the system must be provided to remove the trapped air or this type valve should not be used.

#### B. OPEN CENTER-

With this type valve, when in the center position, the inlet port(s) is blocked and the two outlet ports are open to the exhaust port(s) of the valve. If having no air in either outlet port would present a hazard in the application or servicing, this type valve should not be used.

#### C. PRESSURE CENTER-

With this type valve, when in the center position, the inlet port(s) is connected to both outlet ports of the valve. If having pressurized air to either or both outlet ports would present a hazard in the application or servicing of the valve or system, a separate method in the system must be provided to remove the retained air or this type valve should not be used.

#### OPERATING SPECIFICATIONS -

MAC Valves products are to be installed only on applications that meet all operating specifications described in the MAC catalog for the MAC Valves product.

#### MANUAL OPERATORS-

Most MAC valves can be ordered with manual operators. Manual operators when depressed, are designed to shift the valve to the same position as would the corresponding solenoid or remote air pilot operator if it were activated. Care must be taken to order a type, if any, that will be safe for the physical location of the manual operator in the system. If intentional or accidental operation of a valve by a manual operator could cause personal injury or property damage, a manual operator should not be used.

#### REMOTE AIR OPERATED VALVES

Pilot valves supplying signal pressure to remote air operated valves should be 3-way valves with adequate supply and exhaust capacity to provide positive pressurizing and exhausting of the pilot supply line. Pilot lines should be open to exhaust when valves are deenergized.

#### INSTALLATION PRECAUTIONS :

- A. Do not install any MAC Valves product without first turning off air (bleed system completely) and electricity to the machine.
- B. MAC Valves products should only be installed by qualified, knowledgeable personnel who understand how the specific valve is to be pneumatically piped and electrically connected (where applicable). Flow paths through the valve are shown in the catalog and on the valve by use of ANSI or ISO type standard graphic symbols. Do not install unless these symbols and the valve functions and operations are thoroughly understood.
- C. If air line lubrication is used do not use any lubrication other than those recommended in the catalog, parts & operation sheet or by the factory.

#### SERVICE PRECAUTIONS :

- A. Do not service or remove from service any MAC Valves product without first shutting off both the air and electricity to the valve and making certain no pressurized air which could present a hazard is retained in the system.
- B. MAC Valves products should only be serviced or removed from service by qualified, knowledgeable personnel who understand how the specific product is used and/or how the specific valve is piped and used and whether there is air retained in the connecting lines to the valve or electric power still connected to the valve.
- C. Before attempting to repair, adjust or clean a MAC Valves product, consult catalog, parts & operation sheet, or factory for proper maintenance procedures, lubrication and cleaning agents. Never attempt to repair or perform other maintenance with air pressure to the valve.
- D. MAC Valves products are never to be stepped on while working on a machine. Damage to a MAC valve, or other product or lines to the product (either air or electrical lines) or accidental activation of a manual operator on the valve could result in personal injury or property damage.



# MAC Valves Product Warranty Information

---

## **MAC VALVES Warranty, Warranty Limitations**

---

The MAC Valves organization has established a reputation over many years for fulfilling the needs and requirements of the users of its products. All MAC Valves are quality products specifically designed and built for long and rugged service. For this reason, MAC Valves is able to provide the Buyer a limited warranty.

### **WARRANTY:**

MAC Valves, Inc. hereby warrants to Buyer that, for a period of 18 months from the original date of shipment of each valve from our factory ("Warranty Period"), such valve will be free from significant defects in material and workmanship and will conform to all specifications agreed to by MAC Valves, Inc.. In addition, MAC Valves, Inc. warrants that the electrical coils on such valves will be free from significant defects in material and workmanship for their normal useful life. EXCEPT FOR THESE LIMITED WARRANTIES, MAC VALVES, INC. EXPRESSLY DISCLAIMS ALL REPRESENTATIONS AND WARRANTIES OF ANY KIND (WHETHER EXPRESS, IMPLIED OR ARISING BY OPERATION OF LAW) WITH RESPECT TO THE VALVES, INCLUDING, WITHOUT LIMITATION, ANY WARRANTIES OR REPRESENTATIONS AS TO MERCHANTABILITY, FITNESS FOR A PARTICULAR PURPOSE OR ANY OTHER MATTER. THIS SECTION SURVIVES THE EXPIRATION, TERMINATION OR CANCELLATION OF ANY AGREEMENTS BETWEEN THE PARTIES RELATING TO THE PURCHASE OF THE VALVES.

### **WARRANTY LIMITATIONS:**

This Warranty does not apply where the valves have been (i) subjected to abuse, misuse, damage, neglect, negligence, accident, improper testing, improper installation, improper storage, improper handling, abnormal physical stress, abnormal environmental condition, or use contrary to any instructions issued by MAC Valves, Inc.; (ii) modified, reconstructed, repaired, or altered by persons other than MAC Valves, Inc. or its authorized representative; or (iii) used with any third-party product, hardware, software or other product that has not been previously approved in writing by MAC Valves, Inc. Additionally, this Warranty does not cover claims for labor, material, time or transportation, and does not apply to loss or damage caused by fire, theft, riot, explosion, labor dispute, act of God, or other causes beyond the control of MAC Valves, Inc.

### **EXCLUSIVE REMEDY:**

The Buyer's sole remedy under this Warranty is limited to the replacement or rebuilding of any valve which does not conform to the warranties provided herein or, in MAC Valves, Inc.'s sole discretion, refund of the purchase price for the non-conforming valve. Buyer's remedy is conditioned on Buyer's compliance with its obligations under this Warranty. Valves that Buyer believes do not conform to this Warranty must be returned (with or without bases) transportation prepaid and received at our factory within the Warranty Period. If MAC Valves, Inc. determines that the valve is non-conforming and is otherwise covered by this Warranty, the rebuilt or replaced valve will be returned to the customer at the expense of MAC Valves, Inc. MAC VALVES, INC. WILL NOT BE RESPONSIBLE FOR ANY INCIDENTAL, SPECIAL, EXEMPLARY OR CONSEQUENTIAL DAMAGES, INCLUDING WITHOUT LIMITATION DIRECT AND INDIRECT LOST PROFITS, REGARDLESS OF WHETHER THOSE DAMAGES WERE FORESEEABLE.



---

**Notes**

---

A series of horizontal dotted lines for taking notes.

®  
**MAC**

V A L V E S

**MAC VALVES, INC.**

P.O. BOX 111  
30569 BECK ROAD  
WIXOM, MI 48393-7011

TEL: 1 (248) 624-7700  
FAX: 1 (248) 624-0549  
E-mail: [Mac@macvalves.com](mailto:Mac@macvalves.com)  
Web Site: [www.macvalves.com](http://www.macvalves.com)

**MAC VALVES EUROPE, INC.**

RUE MARIE CURIE, 12  
B-4431 ANS (LIEGE)  
BELGIUM

TEL: 32 (4) 239 68 68  
FAX: 32 (4) 263 19 42  
E-mail: [Info@macvalves.be](mailto:Info@macvalves.be)

**MAC VALVES PACIFIC, INC.**

P.O. BOX 12221  
PENROSE, AUCKLAND  
NEW ZEALAND

TEL: 64 (9) 634-9400  
FAX: 64 (9) 634-9401  
E-mail: [Macvalves@extra.co.nz](mailto:Macvalves@extra.co.nz)

**MAC VALVES, INC.**

5555 ANN ARBOR ROAD  
DUNDEE, MICHIGAN (MI) 48131  
U.S.A.

TEL: 1 (734) 529-5099  
FAX: 1 (248) 863-2111

